

PROVEN PERFORMANCE

Customers in over 60 countries and in diverse markets and sectors.



UK & Ireland Official Distributor



Motion Control Products Ltd.
11-15 Francis Avenue, Bournemouth
Dorset, UK, BH11 8NX
Tel.: +44 (0)1202 599922
enquiries@motioncontrolproducts.com
www.motioncontrolproducts.com

Kinco® Automation

www.en.kinco.cn Email:sales@kinco.cn

(All trademarks and logos in this brochure are property of and registered by their respective owners.)

Kinco



Motion Control
Servo System

Low-voltage Servo System Catalog

- FD1X4S Servo Drive
- OD1X4S Servo Drive
- MD series integrated Servo Motor
- Low-voltage Servo Motor



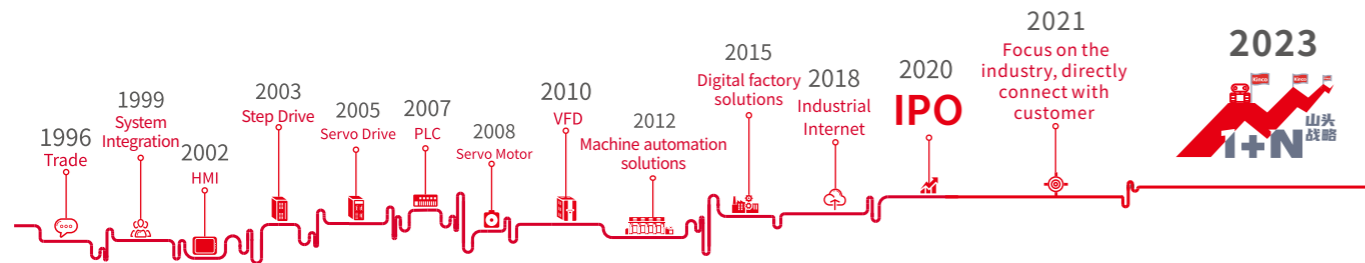

Shanghai Kinco Automation Co., Ltd. focuses on R&D, production, sales and technical services of automation standard products and intelligent hardware products, which is a leading supplier of machine automation and intelligent solutions for factories in China.

In 1996, Kinco has been providing total automation solutions for global industrial automation equipment manufacturers by relying on standard automation products such as HMI, servo system, stepping system, PLC, low-voltage inverter, etc. to penetrate into the industry, making China's automation solutions prevail all over the world. The company's HMI products have led the wave of HMI popularization in China, and its market share has maintained a leading position among local brand manufacturers for many years.

With the mission of "Making China's manufacturing become the top manufacturing in the world", Kinco company insists on investing a large amount of resources in the research and development of automated technology platforms, and sets up R&D facilities in Shanghai, Shenzhen and Changzhou. Kinco company has an automated technology platform that covers all aspects of control, drive, human-machine interaction, communication and electromechanical integration design. In the field of machine automation, Kinco focuses on the industry and has developed special solutions for logistics automation, service robots, medical instruments, professional drones, 3C machine tools, ozone and other industries.

In the field of smart factory, Kinco provides customers with the most easy-to-implement smart factory solutions for manufacturing companies at the field implementation level, PLC control and communication level, Scada and system integration level, and MES management level through its comprehensive automation technology platform and software system developed for smart factory.

With the vision of "creating a better life intelligently" and adhering to the values of "maintain conscience in growth and hold ingenuity in innovation", Kinco is a platform to help employees maximize their creative potential and a partner to help customers succeed in innovative management. We develop products and operate businesses with innovative thinking and practical spirit, adhere to ideals, and expect human creativity to make the world more wonderful.

Kinco low voltage servo system

FD, OD, MD series low-voltage servo drives are a new generation of products with small size, good performance and high stability developed by Kinco Electric after years of market research and according to the characteristics of the logistics automation industry.

The working voltage of Kinco low voltage servo system is DC24~60V. Support CAN, Modbus, Ethercat, Profinet bus and pulse and other control methods. It can be matched with encoder motors such as photoelectric, magnetolectric, multi-turn absolute value, etc., and the product configuration is more flexible. Widely used in logistics storage equipment, mobile handling equipment, sorting trolleys, mobile service robots and other fields that have high requirements on voltage and volume.

For industrial customers who have special requirements in communication mode, installation mode, protection level, etc., our company also provides customized low-voltage servo drives and motors for customer application.

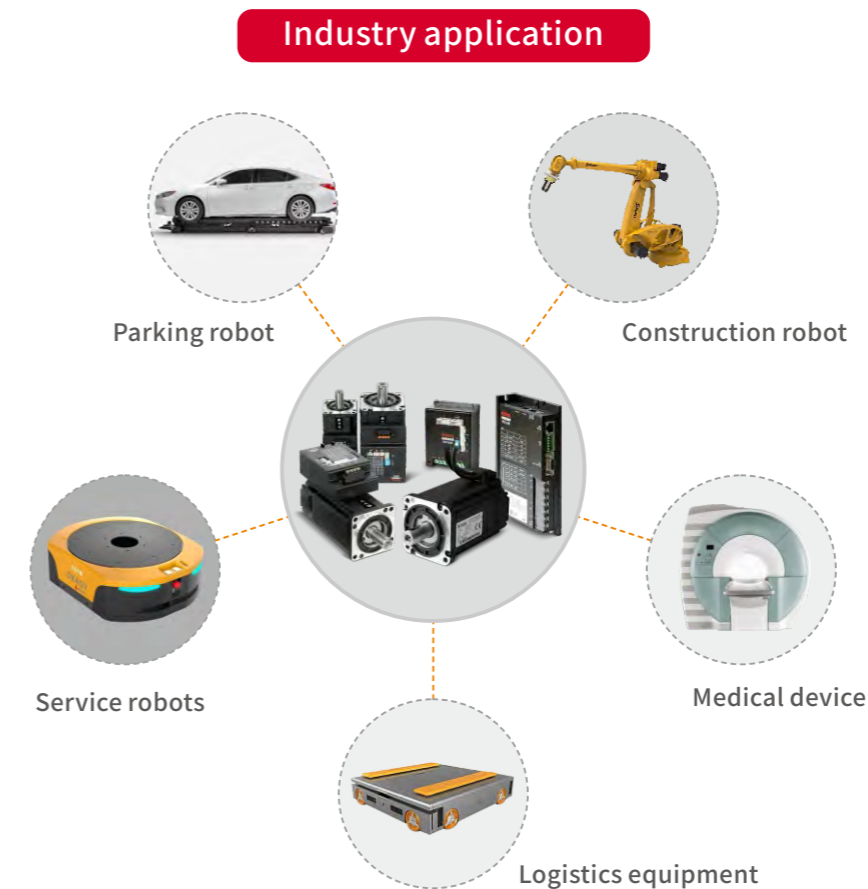

03 Configuration table

Motor and drive configuration table

09 Low voltage servo drive

Drive introduction

Naming rules

Technical parameter table

Mechanical dimension diagram

Wiring port description

29 Integrated servo motors

Motor introduction

Naming rules

Technical parameter table

Mechanical dimension diagram

Wiring port port description

34 Servo motors

Model description/model list

Motor dimension diagram

44 Motor cables

Naming rules

Power wire

Encoder wire

Holding brake wire

Standards and Certificates



European Standards
 Drive: EN 61800-5-1:2007/A11:2021
 Motor: EN 60034-1:2010
 American Standard
 Drive: UL 61800-5-1:2012 R3.15
 Motor: UL 1004-1:2012R11.20



EMC

EMC electromagnetic compatibility certification

Standard : EN 61000-6-4:2007+A1:2011
 Standard : EN 61000-6-2:2005



Magnetolectric encoder servo motor and servo drive configuration table 1 (DC48V)

Power	Servo motor	Description	Brake cable	Power cable	Encoder cable	Servo drive		
						CANopen	RS485+ Plus	EtherCAT
50W	SMC40S-0005-30MAK-5DSU	Magnetolectric encoder motor	-	MOT-005-LL-KL-D	FD1X4S Drive: ENCHG-LL-GU	FD114S-CB-000 OD114S-CA-000	FD114S-LB-000 OD114S-LA-000	FD114S-EB-000 OD114S-EA-000
	SMC40S-0005-30MBK-5DSU	Magnetolectric encoder brake motor	BRA-LL-KL					
100W	SMC40S-0010-30MAK-5DSU	Magnetolectric encoder motor	-	MOT-005-LL-KL-D	FD1X4S Drive: ENCHG-LL-GU	FD124S-CB-000 OD124S-CA-000	FD124S-LB-000 OD124S-LA-000	FD124S-EB-000 OD124S-EA-000
	SMC40S-0010-30MBK-5DSU	Magnetolectric encoder brake motor	BRA-LL-KL					
200W	SMC60S-0020-30MAK-5DSU	Magnetolectric encoder motor	-	MOT-008-LL-KL-D	FD1X4S Drive: ENCHG-LL-GU	FD134S-CB-000 OD134S-CA-000	FD134S-LB-000 OD134S-LA-000	FD134S-EB-000 OD134S-EA-000
	SMC60S-0020-30MBK-5DSU	Magnetolectric encoder brake motor	BRA-LL-KL					
400W	SMC60S-0040-30MAK-5DSU	Magnetolectric encoder motor	-	MOT-008-LL-KL-D	OD1X4S Drive: ENCOG-LL-GU	FD144S-CB-000 OD144S-CA-000	FD144S-LB-000 OD144S-LA-000	FD144S-EB-000 OD144S-EA-000
	SMC60S-0040-30MBK-5DSU	Magnetolectric encoder brake motor	BRA-LL-KL					
600W	SMC60S-0060-30MAK-5DSU	Magnetolectric encoder motor	-	MOT-020-LL-KL-SP	FD1X4S Drive: MOT-020-LL-KL-SP OD1X4S Drive: MOT-020-LL-KL-SP-1	FD134S-CB-000 OD134S-CA-000	FD134S-LB-000 OD134S-LA-000	FD134S-EB-000 OD134S-EA-000
	SMC60S-0060-30MBK-5DSU	Magnetolectric encoder brake motor	BRA-LL-KL					
750W	SMC80S-0075-30MAK-5DSU	Magnetolectric encoder motor	-	MOT-020-LL-KL-SP-1	FD1X4S Drive: MOT-020-LL-KL-SP-1	FD144S-CB-000 OD144S-CA-000	FD144S-LB-000 OD144S-LA-000	FD144S-EB-000 OD144S-EA-000
	SMC80S-0075-30MBK-5DSU	Magnetolectric encoder brake motor	BRA-LL-KL					
1000W	SMC80S-0100-30MAK-5DSU	Magnetolectric encoder motor	-	MOTF-030-LL-KL-SP	ENCHG-LL-GU	FD144S-CB-000 OD144S-CA-000	FD144S-LB-000 OD144S-LA-000	FD144S-EB-000 OD144S-EA-000
	SMC80S-0100-30MBK-5DSU	Magnetolectric encoder brake motor	BRA-LL-KL					

Note: "LL" in the power line/brake line/encoder line list indicates the cable length, please refer to the model description.

2500P/R photoelectric encoder servo motor and servo drive configuration table 2 (DC48V)

Power	Servo motor	Description	Brake cable	Power cable	Encoder cable	Servo drive		
						CANopen	RS485+ Pluse	EtherCAT
200W	SMC60S-0020-30AAK-5DSH	2500P/R photoelectric encoder motor	-	MOT-005-LL-KL-D	FD124S-CB-000 OD124S-CA-000	FD124S-LB-000 OD124S-LA-000	FD124S-EB-000 OD124S-EA-000	
	SMC60S-0020-30ABK-5DSH	2500P/R photoelectric encoder brake motor	BRA-LL-KL					
400W	SMC60S-0040-30AAK-5DSH	2500P/R photoelectric encoder motor	-	MOT-008-LL-KL-D	FD1X4S Drive: ENCHA-LL-KH	FD1X4S Drive: ENCHA-LL-KH	FD1X4S Drive: ENCHA-LL-KH	
	SMC60S-0040-30ABK-5DSH	2500P/R photoelectric encoder brake motor	BRA-LL-KL					
600W	SMC60S-0060-30AAK-5DSH	2500P/R photoelectric encoder motor	-	MOT-020-LL-KL-SP OD1X4S Drive: ENCOA-LL-KH	FD1X4S Drive: ENCOA-LL-KH	FD1X4S Drive: ENCOA-LL-KH	FD1X4S Drive: ENCOA-LL-KH	
	SMC60S-0060-30ABK-5DSH	2500P/R photoelectric encoder brake motor	BRA-LL-KL					
750W	SMC80S-0075-30AAK-5DSH	2500P/R photoelectric encoder motor	-	MOT-020-LL-KL-SP-1	FD134S-CB-000 OD134S-CA-000	FD134S-LB-000 OD134S-LA-000	FD134S-EB-000 OD134S-EA-000	
	SMC80S-0075-30ABK-5DSH	2500P/R photoelectric encoder brake motor	BRA-LL-KL					
1000W	SMC80S-0100-30AAK-5DSH	2500P/R photoelectric encoder motor	-	MOTF-030-LL-KL-SP	ENCHA-LL-KH	ENCHA-LL-KH	ENCHA-LL-KH	
	SMC80S-0100-30ABK-5DSH	2500P/R photoelectric encoder brake motor	BRA-LL-KL					
1.2kW	SMC80S-0120-30AAK-5DSH	2500P/R photoelectric encoder motor	-	MOT-040-LL-KC5	FD144S-CB-000	FD144S-LB-000	FD144S-EB-000	
	SMH110D-0120-30AAK-4DKR	2500P/R photoelectric encoder aviation socket motor	-					
1.5kW	SMC130D-0150-30AAK-4DKR	2500P/R photoelectric encoder aviation socket motor	-	MOT-040-LL-KC5-B	ENCHA-LL-KC0	ENCHA-LL-KC0	ENCHA-LL-KC0	
	SMC130D-0120-30ABK-4DKR	2500P/R photoelectric encoder aviation socket brake motor	-					

Note: "LL" in the power line/brake line/encoder line list indicates the cable length, please refer to the model description.

Ultra-short servo motor and servo drive configuration table 3 (DC48V)

Power	Servo motor	Description	Brake cable	Power cable	Encoder cable	Servo drive		
						CANopen	RS485+ Pluse	EtherCAT
200W	SMC60S-0020-30WAK-5DCH	2500P/R incremental magnetolectric encoder motor	-	MOT-005-LL-KL-D	FD1X4S Drive: ENCHA-LL-KH	FD124S-CB-000 OD124S-CA-000	FD124S-LB-000 OD124S-LA-000	FD124S-EB-000 OD124S-EA-000
	SMC60S-0020-30WBK-5DCH	2500P/R incremental magnetolectric encoder brake motor	BRA-LL-KL					
400W	SMC60S-0040-30WAK-5DCH	2500P/R incremental magnetolectric encoder motor	-	MOT-008-LL-KL-D	OD1X4S Drive: ENCOA-LL-KH	FD134S-CB-000 OD134S-CA-000	FD134S-LB-000 OD134S-LA-000	FD134S-EB-000 OD134S-EA-000
	SMC60S-0040-30WBK-5DCH	2500P/R incremental magnetolectric encoder brake motor	BRA-LL-KL					
750W	SMC80S-0075-30WAK-5DCH	2500P/R incremental magnetolectric encoder motor	-	MOT-020-LL-KL-SP OD1X4S Drive: MOT-020-LL-KL-SP-1	ENCHA-LL-KH	FD144S-CB-000	FD144S-LB-000	FD144S-EB-000
	SMC80S-0075-30WBK-5DCH	2500P/R incremental magnetolectric encoder brake motor	BRA-LL-KL					
1000W	SMC80S-0100-30WAK-5DCH	2500P/R incremental magnetolectric encoder motor	-	MOTF-030-LL-KL-SP	ENCHA-LL-KH	FD144S-CB-000	FD144S-LB-000	FD144S-EB-000
	SMC80S-0100-30WBK-5DCH	2500P/R incremental magnetolectric encoder brake motor	BRA-LL-KL					

Note: "LL" in the power line/brake line/encoder line list indicates the cable length, please refer to the model description.

Low-voltage high-power servo motor and servo drive configuration table 4 (DC48V)

Power	Servo motor	Description	Brake cable	Power cable	Encoder cable	Servo drive		
						CANopen	RS485+ Pluse	EtherCAT
1500W	SMC130D-0150-30WAK-4DSH-2	2500P/R incremental magnetolectric encoder motor	-			FD144S-CB-000	FD144S-LB-000	FD144S-EB-000
	SMC130D-0150-30WBK-4DSH-2	2500P/R incremental magnetolectric encoder brake motor	-					
2500W	SMC130D-0250-30WAK-4DSH-2	2500P/R incremental magnetolectric encoder motor	-			FD164S-CB-000	FD164S-LB-000	
	SMC130D-0250-30WBK-4DSH-2	2500P/R incremental magnetolectric encoder brake motor	-					
3000W	SMC130D-0300-30WAK-4DSH-2	2500P/R incremental magnetolectric encoder motor	-			FD164S-CB-000	FD164S-LB-000	
	SMC130D-0300-30WBK-4DSH-2	2500P/R incremental magnetolectric encoder brake motor	-					
	SMC130D-0300-20WAK-4DSH-2	2500P/R incremental magnetolectric encoder motor	-					
	SMC130D-0300-20WBK-4DSH-2	2500P/R incremental magnetolectric encoder brake motor	-					

Note: In this table, SMC130 motor body out of 2 meters, directly connected to the drive.No need for additional adapter cable. If you need longer cable, please contact local sales.

Magnetolectric absolute encoder servo motor and servo drive configuration table 5 (DC48V)

Power	Servo motor	Description	Brake cable	Power cable	Encoder cable/ Battery cable	Servo drive	
						CANopen	EtherCAT
50W	SMC40S-0005-30QAK-5DSU	Multiturn magnetolectric absolute value encoder motor	-	MOT-005-LL-KL-D		FD114S-CB-005	FD114S-EB-005
	SMC40S-0005-30QBK-5DSU	Multiturn magnetolectric absolute value encoder brake motor	BRA-LL-KL				
100W	SMC40S-0010-30QAK-5DSU	Multiturn magnetolectric absolute value encoder motor	-	MOT-005-LL-KL-D		FD114S-CB-005	FD114S-EB-005
	SMC40S-0010-30QBK-5DSU	Multiturn magnetolectric absolute value encoder brake motor	BRA-LL-KL				
200W	SMC60S-0020-30QAK-5DSU	Multiturn magnetolectric absolute value encoder motor	-	MOT-008-LL-KL-D	ENCHG-(4)-GU-DC★ ENCDG-LL-GU	FD124S-CB-005	FD124S-EB-005
	SMC60S-0020-30QBK-5DSU	Multiturn magnetolectric absolute value encoder brake motor	BRA-LL-KL				
400W	SMC60S-0040-30QAK-5DSU	Multiturn magnetolectric absolute value encoder motor	-	MOT-008-LL-KL-D	ENCHG-(4)-GU-DC★ ENCDG-LL-GU	FD124S-CB-005	FD124S-EB-005
	SMC60S-0040-30QBK-5DSU	Multiturn magnetolectric absolute value encoder brake motor	BRA-LL-KL				
600W	SMC60S-0060-30QAK-5DSU	Multiturn magnetolectric absolute value encoder motor	-	MOT-020-LL-KL-SP		FD134S-CB-005	FD134S-EB-005
	SMC60S-0060-30QBK-5DSU	Multiturn magnetolectric absolute value encoder brake motor	BRA-LL-KL				
750W	SMC80S-0075-30QAK-5DSU	Multiturn magnetolectric absolute value encoder motor	-	MOT-020-LL-KL-SP		FD134S-CB-005	FD134S-EB-005
	SMC80S-0075-30QBK-5DSU	Multiturn magnetolectric absolute value encoder brake motor	BRA-LL-KL				
1000W	SMC80S-0100-30QAK-5DSU	Multiturn magnetolectric absolute value encoder motor	-	MOTF-030-LL-KL-SP		FD144S-CB-005	FD144S-EB-005
	SMC80S-0100-30QBK-5DSU	Multiturn magnetolectric absolute value encoder brake motor	BRA-LL-KL				

Note:1. "LL" in the power line/brake line/encoder line list indicates the cable length, please refer to the model description.

2. ★ENCHG-(4)-GU-DC is a necessary battery-powered cable for multi-turn absolute value encoder motors with 40CM cable length (ENCDG-LL-GU is an optional extension cable if the battery cable length cannot meet the field application).

2-in-1 drive configuration table 6(DC48V)

Power	Servo motor	Description	Brake cable	Power cable	Encoder cable	Servo drive	
						CANopen	RS485+ Pluse
200W	SMC60S-0020-30MAK-5DSU	Magnetolectric encoder motor	-	MOTF-(2)-M	ENCOGF-(2)-GU	FD124S-AB-020-D2	FD124S-AB-020-D2 Note: Pulse not supported
	SMC60S-0020-30MBK-5DSU	Magnetolectric encoder brake motor	BRAF-(2)-M				
	SMC60S-0020-30WAK-5DCH	2500P/R incremental magnetolectric encoder motor	-		ENCOAF-(2)-KH		
	SMC60S-0020-30WBK-5DCH	2500P/R incremental magnetolectric encoder brake motor	BRAF-(2)-M				
400W	SMC60S-0040-30MAK-5DSU	Magnetolectric encoder motor	-	MOTF-(2)-M	ENCOGF-(2)-GU	FD124S-AB-020-D2	FD124S-AB-020-D2 Note: Pulse not supported
	SMC60S-0040-30MBK-5DSU	Magnetolectric encoder brake motor	BRAF-(2)-M				
	SMC60S-0040-30WAK-5DCH	2500P/R incremental magnetolectric encoder motor	-		ENCOAF-(2)-KH		
	SMC60S-0040-30WBK-5DCH	2500P/R incremental magnetolectric encoder brake motor	BRAF-(2)-M				
600W	SMC60S-0060-30MAK-5DSU	Magnetolectric encoder motor	-	MOT-020-LL-KL-SP	ENCHG-LL-GU	FD134S-CB-000-D2	FD134S-LB-000-D2
	SMC60S-0060-30MBK-5DSU	Magnetolectric encoder brake motor	BRA-LL-KL				
	SMC60S-0060-30AAK-5DSH	2500P/R photoelectric encoder motor	-		ENCHA-LL-KH		
	SMC60S-0060-30ABK-5DSH	2500P/R photoelectric encoder brake motor	BRA-LL-KL				
750W	SMC80S-0075-30MAK-5DSU	Magnetolectric encoder motor	-	MOT-020-LL-KL-SP	ENCHG-LL-GU	FD134S-CB-000-D2	FD134S-LB-000-D2
	SMC80S-0075-30MBK-5DSU	Magnetolectric encoder brake motor	BRA-LL-KL				
	SMC80S-0075-30AAK-5DSH	2500P/R photoelectric encoder motor	-		ENCHA-LL-KH		
	SMC80S-0075-30ABK-5DSH	2500P/R photoelectric encoder brake motor	BRA-LL-KL				
	SMC80S-0075-30WAK-5DCH	2500P/R incremental magnetolectric encoder motor	-		ENCHA-LL-KH		
	SMC80S-0075-30WBK-5DCH	2500P/R incremental magnetolectric encoder brake motor	BRA-LL-KL				
	SMC80S-0075-30WAK-5DCX-(8)	2500P/R incremental magnetolectric encoder motor	-				

Note:1. "LL" in the powerline/brake line/encoderlinelistindicates the cable length,please refer to the model description.

2. FD124S-AB-020-D2 doesn't support pulse

Introduction of low voltage servo drive

Features:

Control mode: support position, speed, torque control mode

Communication protocol: support CANopen, EtherCAT, RS485 and other communication protocols

Encoder: support photoelectric, magnetic encoder, absolute value and other encoder type motors
Can drive 50W~3Kw low voltage servo motor

Industry-specific: Provide a variety of special functions according to the needs of the AGV industry:
two-in-one drive, alarm braking, enhanced battery life

For customers who are more sensitive to space, we have launched a palm-sized OD series drive,
which can be customized and developed according to different working conditions of users



Drive naming rule

Model: **FD124S-CB-000-D2**

① ② ③ ④ ⑤ ⑥ ⑦

①-Serial number	FD : FD series OD : OD series
②-Voltage input specifications	1: Input voltage DC24~60V
③-Rated output current	1: 5Arms 2: 15Arms 3: 25Arms 4: 40Arms 6: 80Arms
④-Drive version	4S: 4S version low voltage drive
⑤-Control method	AB: RS232, RS485, CANopen LB: RS232, RS485, pluse CB: RS232, CANopen EB: RS232, EtherCAT
⑥-Software version number	000: Incremental encoder (communication, photoelectric encoder) 005: Absolute value encoder 020: mobile specific
⑦-Drive mode	D2: Two-in-one drive Note: Applicable to FD134S series

Note 1, The output currents of FD124S, FD134S, and FD144S are 15Arms, 25Arms, and 40Arms, respectively, which is the value measured by installing the drive on an oxide black 6063 aluminum plate with a length*width*height of 300mm*300mm*10mm of the auxiliary heat sink.

2, The output current of the FD164S is 80Arms, and the drive needs to be installed on the auxiliary radiator with a length*width*height of 400mm*400mm*10mm and the measured value of the black oxide 6063 aluminum plate.

FD1X4S technical specifications table



Model parameters		FD1X4S servo drive technical parameter table				
		FD114S-□□-00	FD124S-□□-00	FD134S-□□-00	FD144S-□□-00	FD164S-□□-000
Rated input voltage		24VDC~60VDC				
Rated output current	Maximum continuous output current (rms)	5A	15A (Up to 12A without auxiliary radiator)	25A (Up to 20A without auxiliary radiator)	40 A (Up to 30 A without auxiliary radiator)	80A (Up to 60A without auxiliary radiator)
	Peak current (PEAK)	12Ap	48Ap	80Ap	120Ap	240Ap
Feedback signal		2500P/R (incremental differential 5V encoder);magnetic encoder;absolute encoder (for FD1X4S-CB-005 and FD1X4S-EB-005)				
Brake chopper		An external braking resistor (depending on the working conditions, mainly used for quick start and stop), the braking voltage absorption point is 73V (FD164S is 63V) (software setting).				
Brake chopper threshold		DC73V ± 2V (default value, can be set)			DC63V ± 2V (default value, can be set)	
Over-voltage alarm voltage		DC83V ± 2V			DC70V ± 2V	
Under-voltage alarm voltage		DC18V±2V			DC18V ± 2V	
Cooling method		Natural cooling Remark1: The output currents of FD124S, FD134S and FD144S are 15Arms, 25Arms and 40Arms respectively. The value measured on an oxide black 6063 aluminum plate of 300mm*300mm*10mm. 2: The output current of FD164S is 80Arms, the drive needs to be installed on the auxiliary radiator. The length*width*height is the value measured on an oxide black 6063 aluminum plate of 400mm*400mm*10mm.				
Weight(Kg)		0.3	0.3	0.6	0.9	1.68
General functions	Input specification	4-channel digital input, common to COMI terminal, high level: 12.5-30VDC, low level: 0-5VDC, maximum frequency: 1KHz, input impedance: 5KΩ.(the brake motor drive is a 3-way digital input)				
	Input function	Freely define as needed, the functions are as follows: drive enable, drive error reset, drive working mode control, speed loop proportional control, positive limit, negative limit, origin signal, command reversal, internal speed segment control, internal position segment control, emergency stop, start to find origin, command activation, electronic gear ratio switching, gain switching				
	Output specification	2 digital outputs, brake motor drive is 1 digital signal output				
	Pulse direction control	Pulse+direction, CCW+CW, A phase+B phase (3.3V~24V) Note: Only FD1X4S-L□□-000 supports this function				
	Output function	Freely define according to needs, the functions are as follows: drive ready, drive error, motor position arrives, motor zero speed, motor holding brake, motor speed arrives, index Z signal appears, maximum speed limit reached in torque mode, motor lock shaft, motor limit bit center, origin found				
	RS232	The default baud rate is 38400 and the maximum baud rate is 115.2K. Can use Kinco host computer software for linking, or use custom protocol to communicate with the controller				
	Protective function	Overvoltage protection, undervoltage protection, motor overheating (I2T) protection, short circuit protection, drive overheating protection, etc.				
Bus function	Modbus/RS485	Maximum support 115.2K baud rate, can use Modbus RTU protocol to communicate with the controller			-	
	CAN BUS	Maximum support 1M baud rate, can use CANopen protocol to communicate with the controller				
	EtherCAT	Support CoE (CiA402 protocol) and CSP/CSV/PP/PV/PT/HM mode, the communication speed is 100M.			-	
Use environment	Operating temperature	0~40°C				
	Storage temperature	- 10°C~70°C				
	Humidity (no condensation)	Below 90%RH				
	Protection level	IP20				
	Installation site	Dust-free and dry place (such as electrical cabinet)				
	Installation method	Vertical installation or horizontal installation				
	Height	The rated working altitude is below 1000m. When the working altitude is above 1000m, every 100m rise, it needs to be derated by 1.5%. The maximum working altitude is 4000m above sea level.				
Atmospheric pressure	86kpa~106kpa					

Note:

1. □=L: Communication port RS232, RS485, pulse 2. 00■=005: Matching absolute value encoder motor
 □=C: Communication port RS232, CANopen
 □=E: Communication port RS232, EtherCAT

OD1X4S technical specifications table



Model parameters		OD1X4S servo drive		
		OD114S-□□-000	OD124S-□□-000	OD134S-□□-000
Rated input voltage	Power supply	24VDC~60VDC		
	Logic power supply	24VDC 1A (unnecessary)		
Rated output current	Maximum continuous output current (rms)	5A	10A (Up to 9A without auxiliary radiator)	20A (Up to 13A without auxiliary radiator)
	Peak current (PEAK)	12Ap	36Ap	80Ap
Feedback signal		2500P/R (incremental differential 5V encoder)Magnetolectric encoder		
Brake chopper		An external braking resistor is required (depending on the operating conditions, mainly used in the occasion of rapid start and stop)		
Brake chopper threshold		DC73V ± 2V (default value, can be set)		
Overvoltage alarm voltage		DC86V ± 2V		
Undervoltage alarm voltage		18V ± 2V		
cooling method		Natural cooling	Natural cooling Remarks:add an oxide black 6063Aluminum radiator with a size of 150mm*150mm*10mm Remarks:add an oxide black 6063Aluminum radiator with a size of 150mm*150mm*10mm	
Weight(KG)		0.266	0.393	
Universal function	Input specification	4-channel digital input, common to COMI terminal, high level: 12.5-30VDC, low level: 0-5VDC, maximum frequency: 1KHz, input impedance: 5KΩ.		
	Input function	Freely define as needed, the functions are as follows: drive enable, drive error reset, drive working mode control, speed loop proportional control, positive limit, negative limit, origin signal, command reversal, internal speed segment control, internal position segment control, emergency stop, start to find origin, command activation, electronic gear ratio switching, gain switching		
	Pulse control	Pulse + direction, CCW + CW, A phase + B phase (3.3V~24V)		
	Analog input	Voltage input range: -10V~+10V; input impedance 200K, input sampling frequency 4KHz		
	Output specification	2-channel digital output (maximum driving current 100mA) 1-channel brake driving output (requires external 24VDC driving current maximum 500mA)		
	Output function	Freely define according to needs, the functions are as follows: drive ready, drive error, motor position arrives, motor zero speed, motor holding brake, motor speed arrives, index Z signal appears, maximum speed limit reached in torque mode, motor lock shaft, motor limit bit center, origin found		
	RS232	Maximum support 115.2K baud rate, can use Kinco host computer software to link, can also use custom protocol to communicate with the controller		
Bus function	Protective function	Overvoltage protection, undervoltage protection, motor overheating (I2T) protection, short circuit protection, drive overheating protection, etc.		
	Modbus/RS485	Maximum support 115.2K baud rate, can use Modbus RTU protocol to communicate with the controller		
	CAN BUS	Maximum support 1M baud rate, can use CANopen protocol to communicate with the controller		
Use environment	EtherCAT	Support CoE (CiA402 protocol) and CSP/CSV/PP/PV/PT/HM mode, the communication speed is 100M.		
	Operating temperature	0~40°C		
	Storage temperature	- 10°C~70°C		
	Humidity	Below 90%RH		
	Protection level	IP20		
	Installation site	Dust-free,dry and lockable (such as electrical cabinets)		
	Installation method	vertical installation		
High	The rated working altitude is below 1000m. When the working altitude is above 1000m, every 100m rise, the derating needs to be reduced by 1.5%. The maximum working altitude is 4000m above sea level.			

- Note: □□=LA: Communication port RS232, RS485, pulse
 □□=CA: Communication port RS232, CANopen, pulse
 □□=EA: Communication port RS232, EtherCAT, pulse

FD134S two-in-one drive technical specifications table



Model parameters		Two-in-one drive			
		FD124S-AB-020-D2	FD134S-LB-000-D2	FD134S-CB-000-D2	FD134S-CB-020-D2
Rated input voltage	Power supply	24VDC~60VDC			
	Built in fuse	Have(20A)	None		
	Logic power supply	Have (24VDC)			
Rated output current	Maximum continuous output current (rms)	15A (up to 12A without auxiliary cooling)	20A (up to 15A without auxiliary cooling)		
	Peak current(PEAK)	20A (Restricted by fuses)	80A		
Feedback signal		2500P/R(incremental differential 5V encoder): magnetolectric encoder			
Energy consumption braking		It can be externally connected with brake resistor (depending on the operation, mainly used in the situation of rapid start and stop), and the brake voltage absorption point is 73V (software setting)			
Energy consumption braking voltage absorption point		DC73V ± 2V (default value, settable)			
Overvoltage alarm voltage		DC83V ± 2V			
Undervoltage alarm voltage		DC18V ± 2V			
Cooling mode		Natural cooling Note: When the output current of the drive is 20A, the drive is installed on the auxiliary radiator, and the length * width * height of the drive is the value measured on 300mm * 300mm * 10mm oxidized 6063 aluminum plate			
Weight (Kg)		0.566	0.9	1.29	
Mechanical dimension (mm)		140*90.8*42.6	207*100.5*33.9	196*124.2*54.6	
General function	Input specification	3-channel digital input: Digital input has COM1 terminal, high level: 12.5~30VDC, low level: 0~5VDC, maximum frequency: 1KHz, input impedance: 5KΩ Note: FD124S-AB-020-D2 & FD134S-CB-020-D2 only 2 digital inputs			
	Input function	It can be freely defined as required, and its functions are as follows: drive enable, drive error reset, drive working mode control, speed loop proportional control, positive limit, negative limit, origin signal, command reverse, internal speed segment control, internal position segment control, emergency stop, start to find origin, command activation, electronic gear ratio switching, gain			
	Output Specification	1 digital output, driving capacity of 100mA		None	
	Output function	Freely defined as needed, the functions are as follows: drive ready, drive error, motor position to, motor zero speed, motor holding brake, motor speed to, index Z signal appears, maximum limit speed is reached under torque mode, motor shaft locking, motor limit center, and origin finding			
	Pulse direction control	None	Pulse+direction, CcW+CW, A phase+B phase (3.3V~24V)	None	None
	Protection function	Overvoltage protection, undervoltage protection, motor overheating (I ² T) protection, short circuit protection, drive overheating protection, etc			
	Brake	1-channel brake output (built-in 24V brake power supply, output capacity is 0.8A), Note: FD124S-AB-020-D2 supports external power output brake and is not controlled by the driver			
RS232	The default baud rate is 38400, and the maximum baud rate is 115.2k. Kinco host computer software can be used to link or custom protocol can be used to communicate with the controller				
Bus function	RS485	Maximum baud rate of 115.2K is supported, and Modbus RTU protocol can be used to communicate with the controller			
	CAN BUS	Maximum IM baud rate is supported, and CANopen protocol can be used to communicate with the controller			
Use environment	Working temperature	0-40°C			
	Storage temperature	-10°C~70°C			
	Humidity (no condensing)	Below 90%RH			
	Protection class	IP20			
	Installation site	Dust free, dry and lockable (such as electrical cabinet)			
	Installation method	Vertical or horizontal installation			
Height	The rated working altitude is below 1000m. When the working altitude is above 1000m, 1.5% derating is required for every 100m rise. The maximum working altitude is 4000m.				
Atmospheric pressure	86kpa-106kpa				

Note: LB: communication port RS232, RS485, pulse CB: communication port RS232, CANopen

FD1X4S Drive mechanical dimension diagram

Note: Wiring is needed around the drive, Recommend leaving distance > 60mm

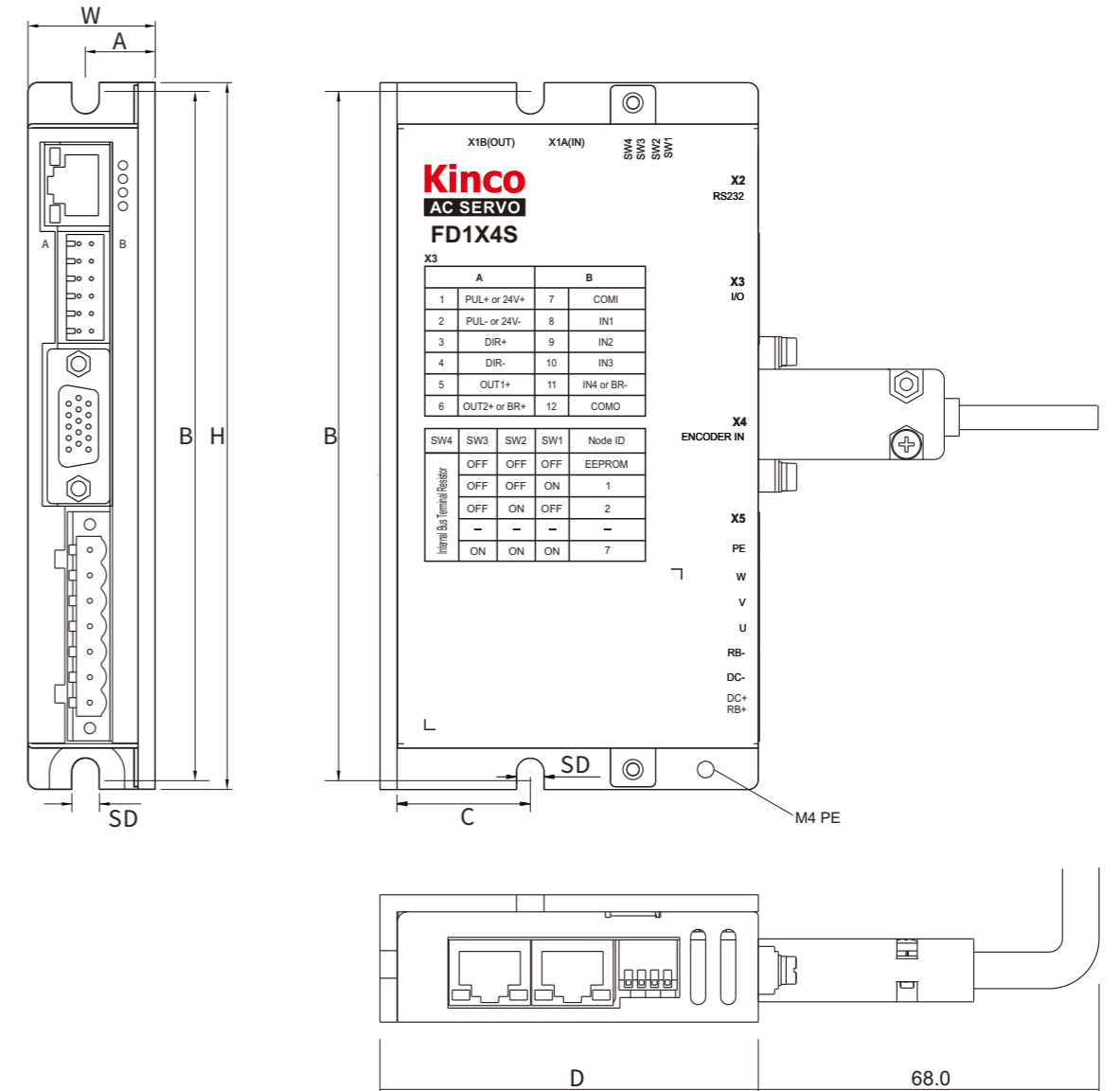

Model	Outline dimension (mm)			Installation dimension (mm)			Mounting aperture SD (mm)
	H	W	D	A	B	C	
FD114S	141	25.4	75.5	14	137.5	30	5.5
FD124S							
FD134S	174.6	31	100.5	18	168	70	5.8
FD144S							

FD164S Drive mechanical dimension diagram

Note: Wiring is needed around the drive, recommend leaving distance > 60mm

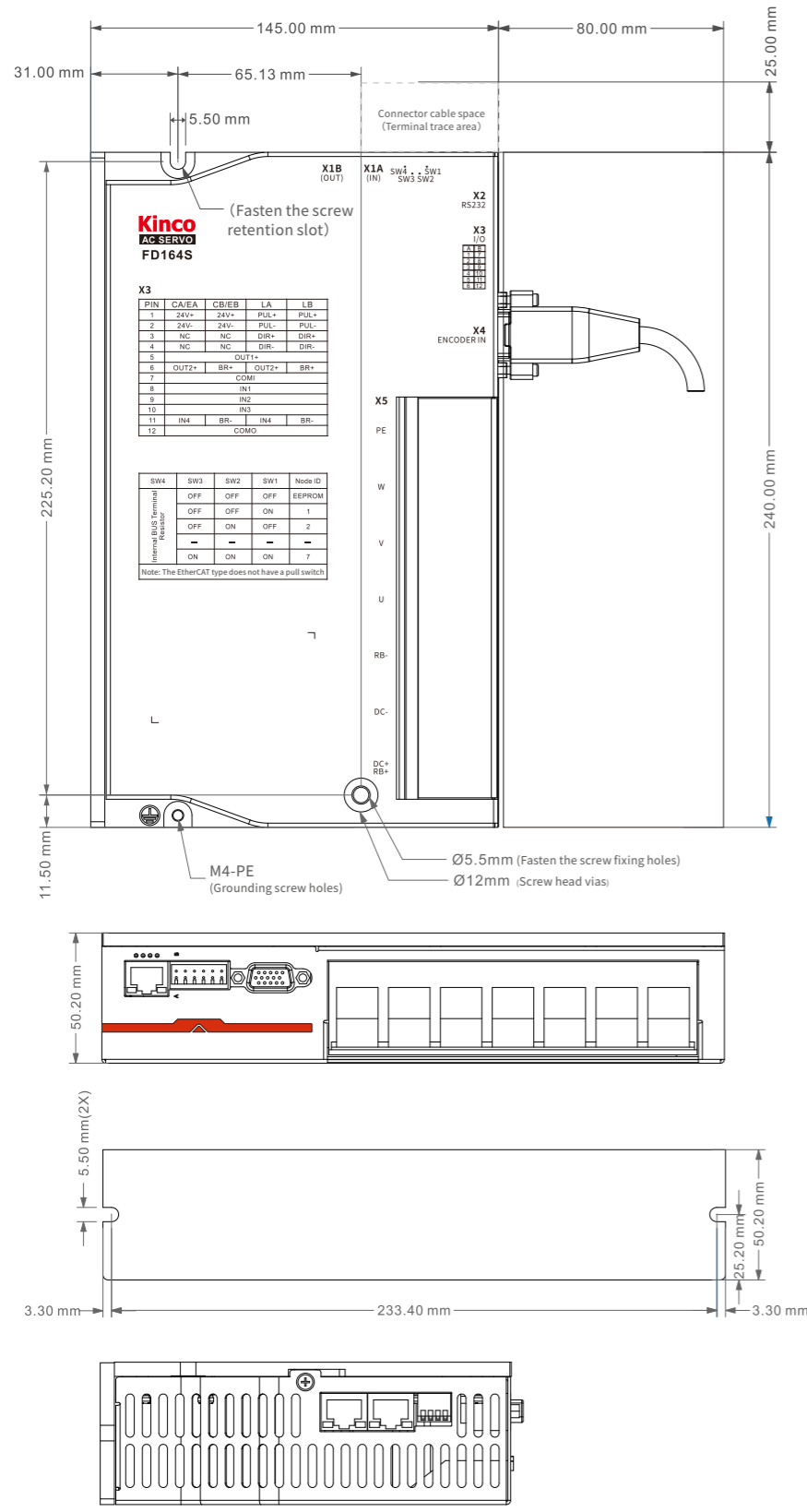

OD1X4S drive mechanical dimension diagram

Note: Wiring is needed around the drive, recommend leaving distance > 60mm

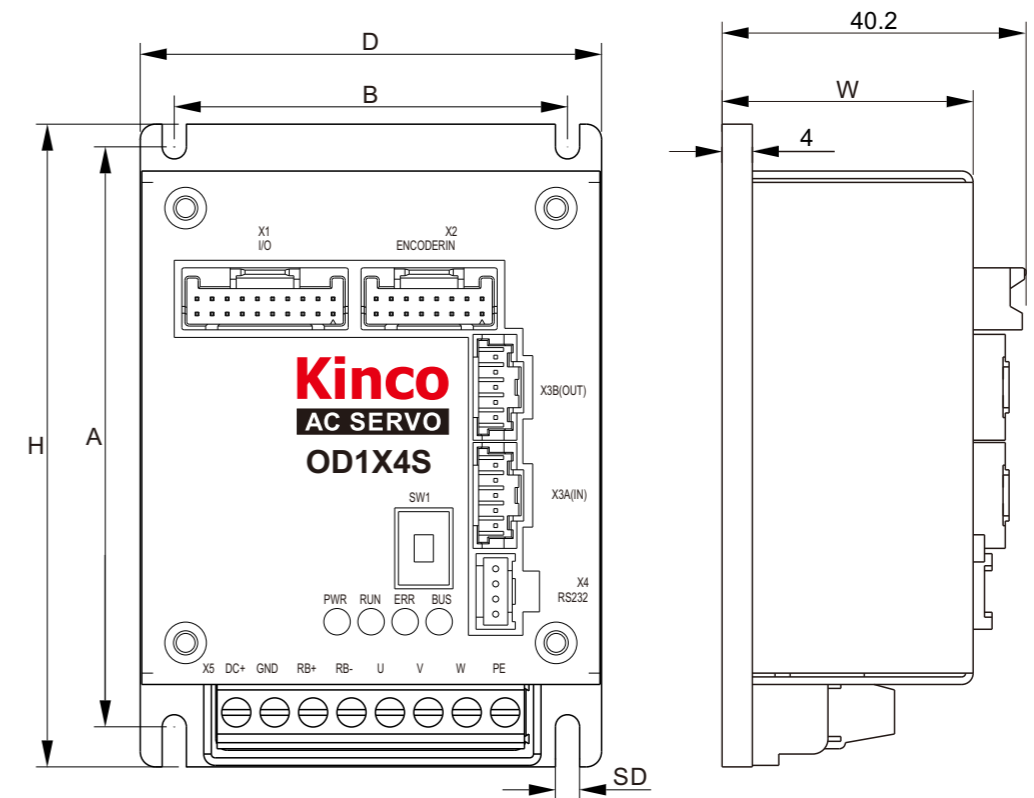

Model	Outline dimension (mm)			Installation dimension (mm)		Mounting aperture SD (mm)
	H	W	D	A	B	
OD114S	85	33.2	61	76.7	52	3.2
OD124S						
OD134S	107	33.2	77.4	101.4	60	

FD124S-AB-020-D2 drive wiring port description

Note: Wiring is needed around the drive, recommend leaving distance > 60mm

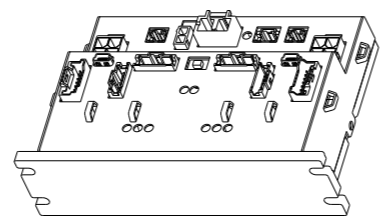
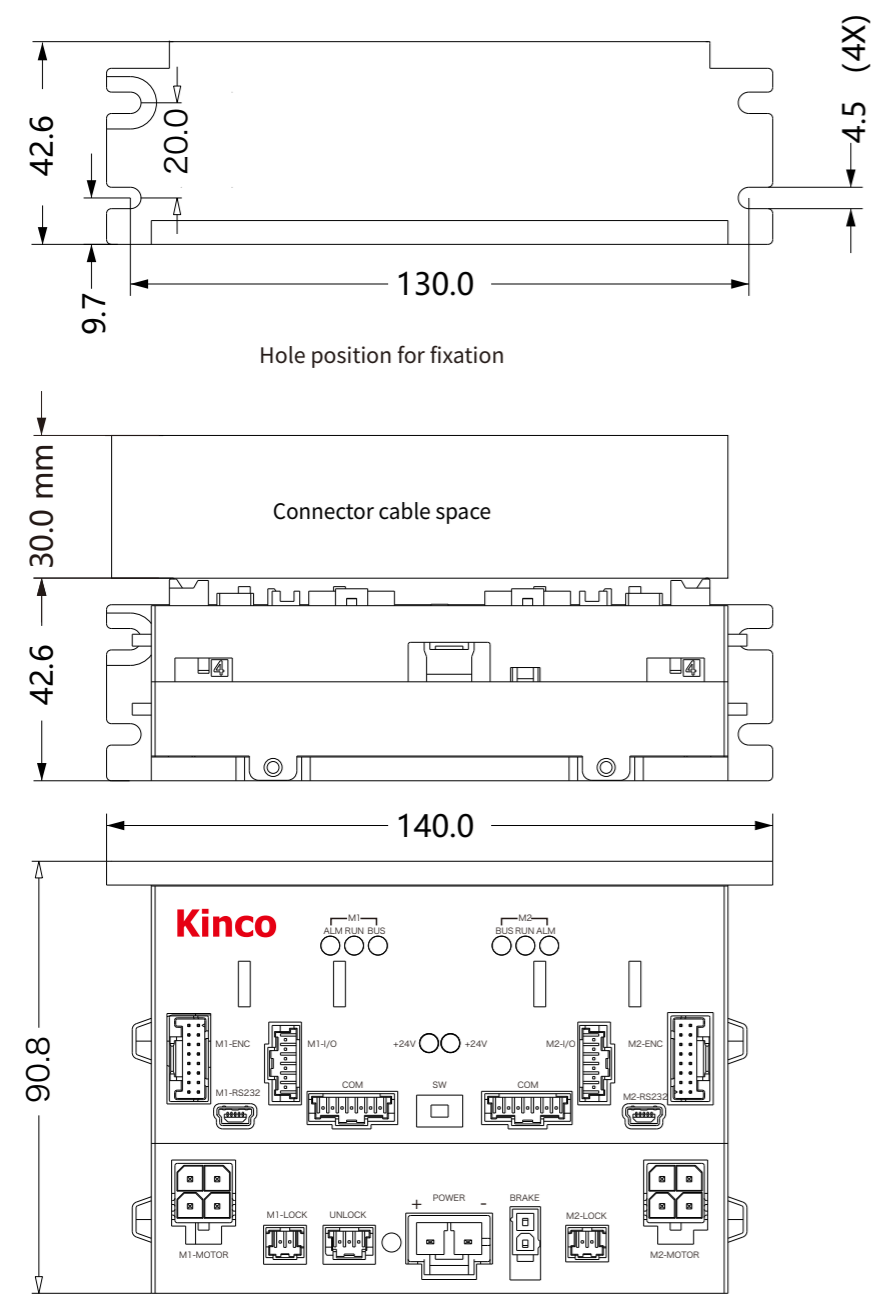

FD134S 2-in-1 driver Drive mechanical dimension diagram

Note: Wiring is needed around the drive, recommend leaving distance > 60mm

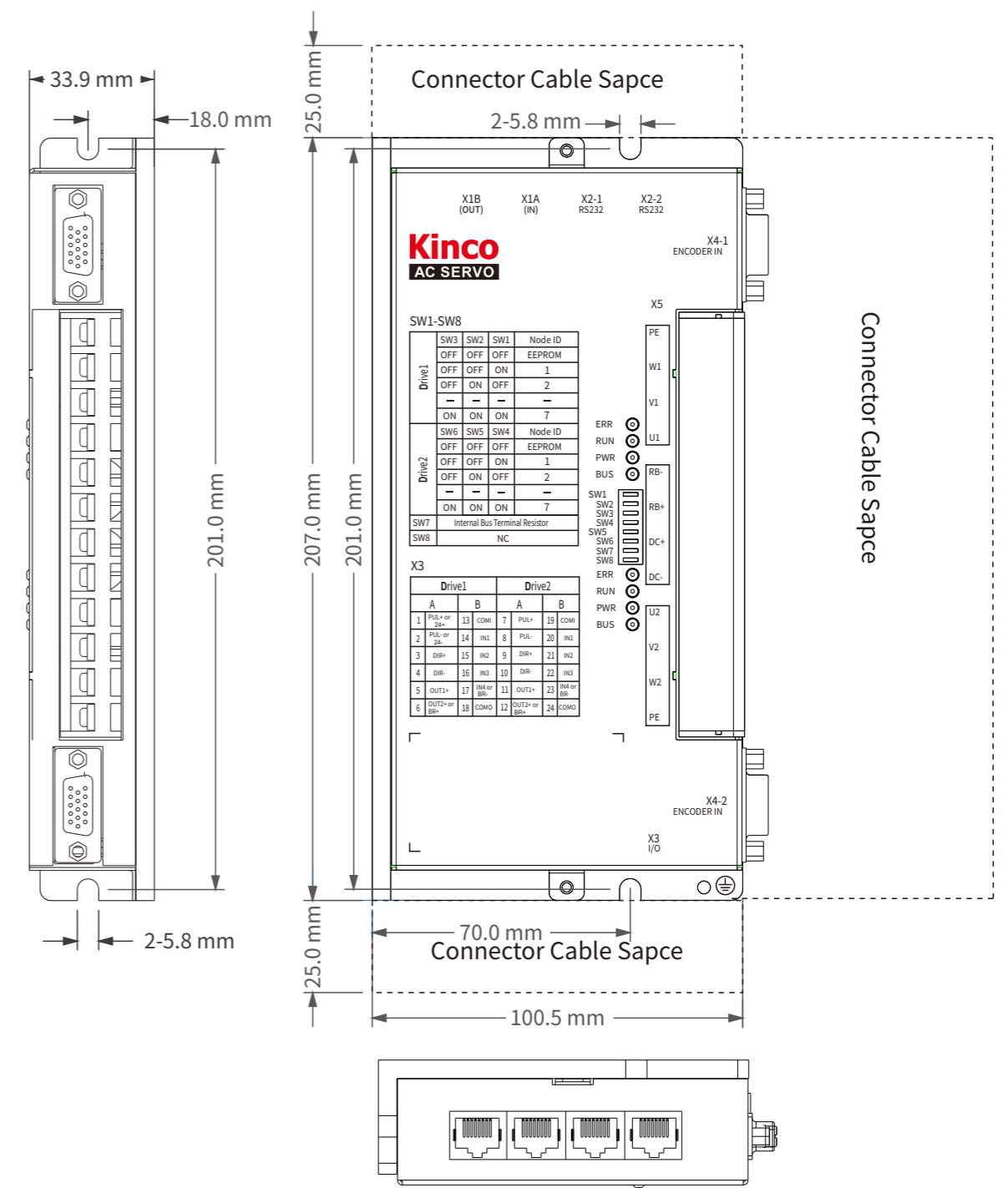

FD1X4S servo drive wiring port description

FD114S, FD124S, FD134S, FD144S, FD164S input and output terminal X3 wiring diagram

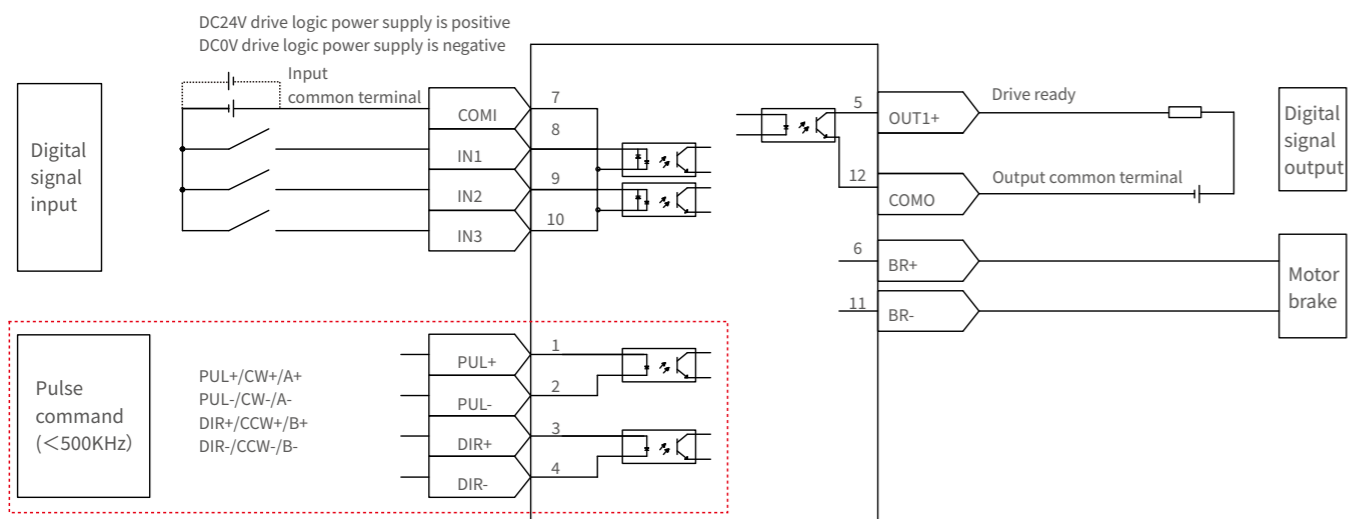

Notes:
FD1X4S-CB-00 and FD1X4S-EB-000 do not hold pulse control;
FD1X4S-LB-00 There is no 24V logic power supply.

Motor encoder input interface

X4

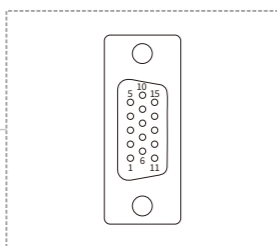

Pin No.	Incremental encoder signal	Communication type magneto-electric encoder signal
1	+5V	VDD
2	GND	GND
3	\	\
4	U	\
5	/U	\
6	Z	\
7	B	\
8	A	\
9	W	SLO_P+
10	V	MA_P+
11	/Z	\
12	/B	\
13	/A	\
14	/W	SLO_N-
15	/V	MA_N-

OD1X4S servo drive wiring port description

Digital signal input/output port

X1

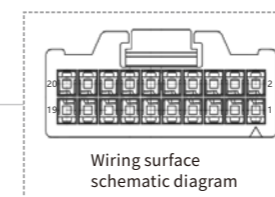

引脚号	信号	描述
1	GND	Logic power input, motor with brake must be connected Voltage: 24VDC; Current: 1A
15	GND	Note: Both Pin1 and Pin15 are GND, there is no difference. Please be able to wiring nearby
2	24V+	
3	OUT2-	
5	OUT2+	Digital signal output
7	OUT1-	Maximum output current: 100mA
9	OUT1+	
11	AIN-	Analog input: ±10V
13	AIN+	Accuracy: 12 bits
17	OUT5-	The brake output needs to be connected to 24VDC externally, and the maximum driving current is 500mA
19	OUT5+	
4	DIR-	
6	DIR+	Input voltage: 3.3V to 24V
8	PUL-	Maximum frequency: 500KHz
10	PUL+	
12	In4	Digital signal input
14	In3	High level: 12.5VDC to 30VDC
16	In2	Low level: 0VDC to 5VDC
18	In1	Input impedance: 5KΩ
20	COMI	Digital signal input common end

Motor encoder input interface

X2

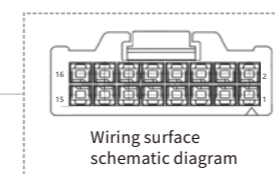

Pin No.	Incremental encoder signal	Magneto-electric encoder signal
1	PTC_IN	\
2	Shield	Shield
3	W	SLO_P+
4	/W	SLO_N-
5	V	MA_P+
6	/V	MA_N-
7	U	\
8	/U	\
9	Z	\
10	/Z	\
11	B	\
12	/B	\
13	A	\
14	/A	\
15	+5V	VDD
16	GND	GND

Bus communication interface

X3

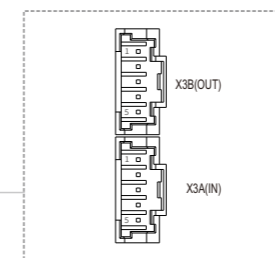

Pin No.	RS485	EtherCAT	CAN
1	RX+	RX+	\
2	RX-	RX-	CAN_H
3	TX-	TX-	CAN_L
4	TX+	TX+	\
5	GND	GND	GND

Note:
Kinco communication cable OD-P5 - (5) can be purchased

Communication interface RS232

X4

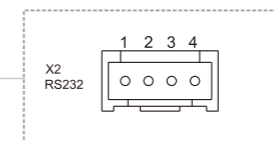

Pin No.	Signal
1	RX
2	TX
3	GND
4	GND

Note:
Kinco communication cable OD124RS232-0.5m can be purchased

OD1X4S servo drive wiring port description

Input/Output Terminal Wiring Diagram (OD1X4S)

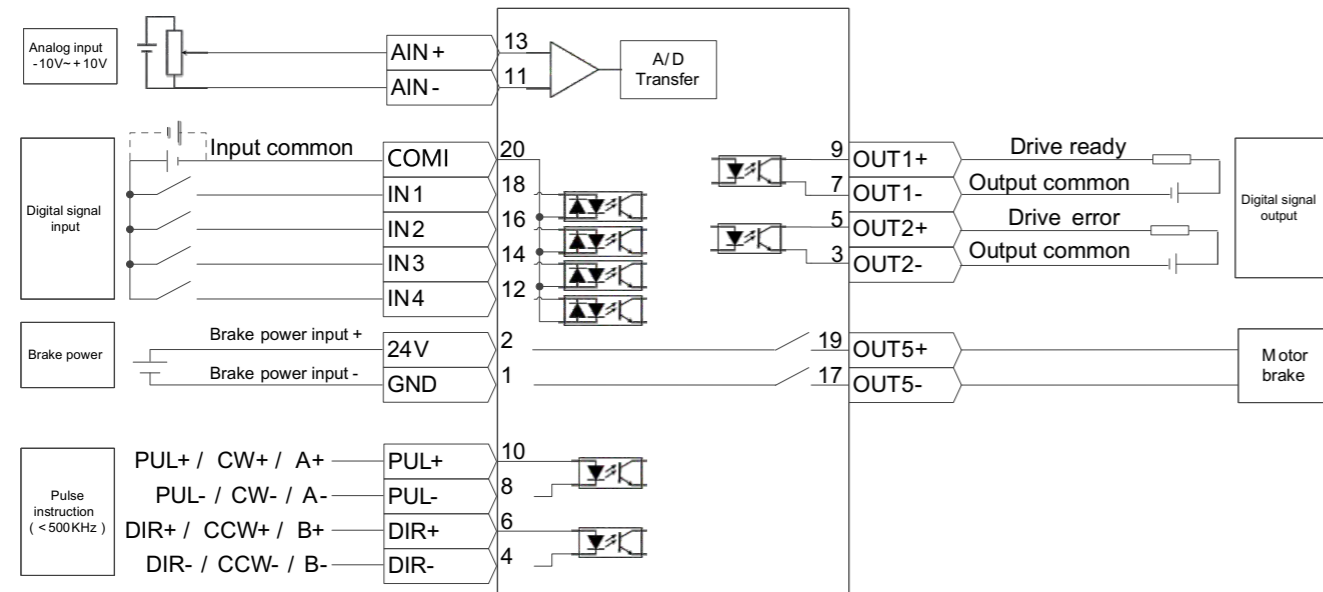

FD124S-AB-020-D2 drive wiring port description

Bus communication interface

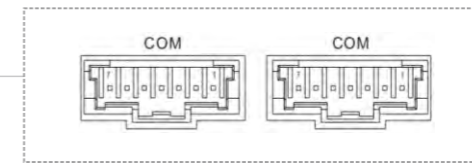

Pin No.	Signal
1	485B
2	485A
3	CANL
4	CANH
5	PE
6	GND
7	+24V

Communication interface RS232

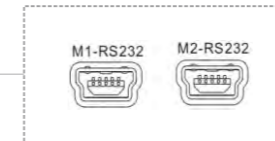

Pin No.	Signal
1	NC
2	RX
3	TX
4	NC
5	GND

Note: Customers can choose Kinco servo commissioning cable-MINIUSB, model PDC-USBM-1 (5)

Motor encoder input interface

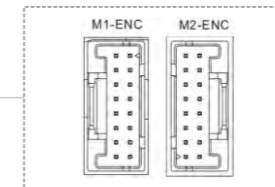

M1-ENC&M2-ENC

Pin No.	Incremental encoder signal	Magnetolectric encoder signal
1	GND	VDD
2	+5V	\
3	/A	\
4	A	\
5	/B	\
6	B	MA_P+
7	/Z	SLO_P+
8	Z	\
9	/U	GND
10	U	\
11	/V	\
12	V	\
13	/W	\
14	W	MA_N-
15	/	SLO_N-
16	Shield	Shield

Digital signal input/output port

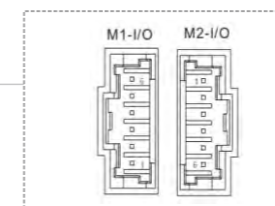

M1-I/O & M1-I/O

Pin No.	Signal
1	In1
2	In2
3	COMI
4	OUT1
5	OUT2
6	COMO

Input/output terminal M1-I/O&M1-I/O wiring diagram

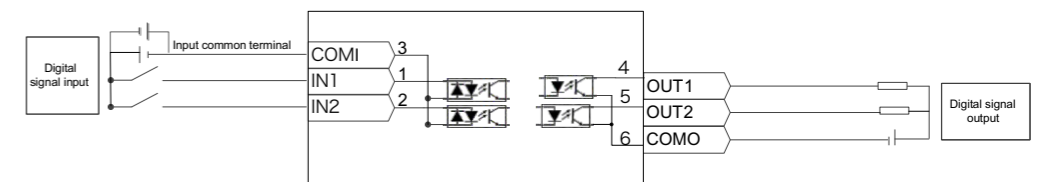

FD134S two-in-one servo drive description of servo drive wiring port

FD134S two-in-one servo drive description of servo drive wiring port

Bus communication interface

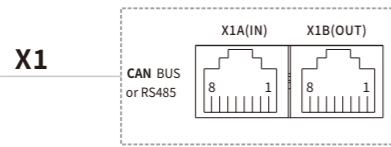

Pin No.	RS485	CAN
1	RX	CAN_H
2	/RX	CAN_L
3	GND	GND
4	/TX	\
5	TX	\
6	\	\
7	\	\
8	\	\

Communication interface RS232

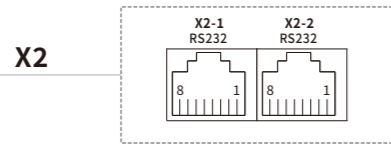

Pin No.	Signal
1	\
2	\
3	TXD
4	GND
5	\
6	RXD
7	\
8	\

Digital signal input/output port

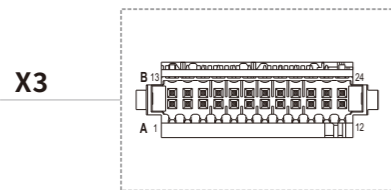

Drive 1			
	A		B
1	PUL+ or 24+	13	COMI
2	PUL- or 24-	14	IN1
3	DIR+	15	IN2
4	DIR-	16	IN3
5	OUT1+	17	IN4 or BR-
6	OUT2+ or BR+	18	COMO

Drive 2			
	A		B
7	PUL+	19	COMI
8	PUL-	20	IN1
9	DIR+	21	IN2
10	DIR-	22	IN3
11	OUT1+	23	IN4 or BR-
12	OUT2+ or BR+	24	COMO

Note: Please refer to the X3 wiring diagram of FD1X4S for the wiring diagram of input and output terminals

Motor encoder input interface

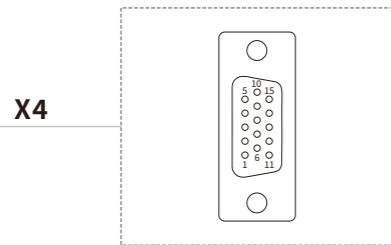

Pin No.	Incremental encoder signal	Communication magnetoelectric coder signal
1	+5V	VDD
2	GND	GND
3	\	\
4	U	\
5	/U	\
6	Z	\
7	B	\
8	A	\
9	W	SLO_P+
10	V	MA_P+
11	/Z	\
12	/B	\
13	/A	\
14	/W	SLO_N-
15	/V	MA_N-

FD134S two in one I/O Terminal X3 wiring diagram

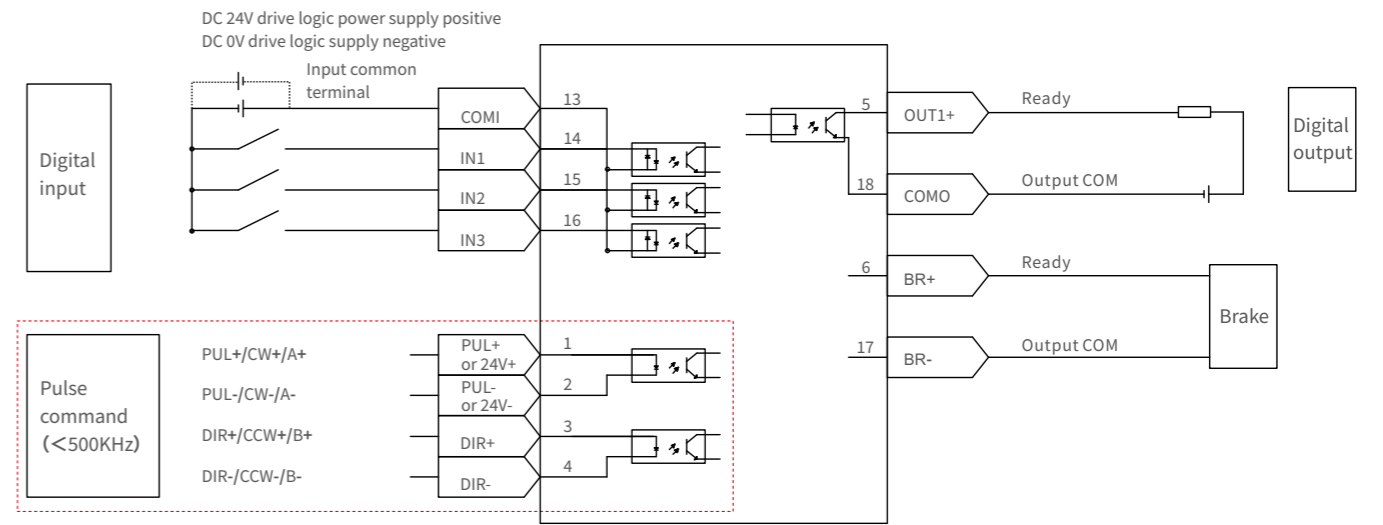

Drive 1

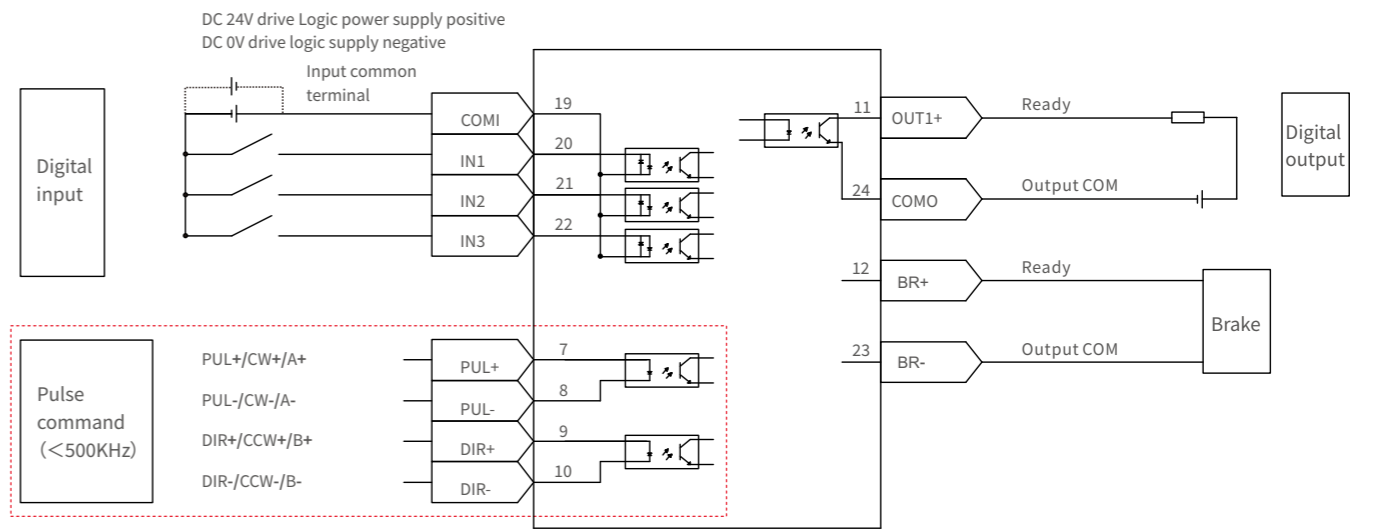

Drive 2

Note:
FD134S-CB-000-D2 don't support pulse control
FD134S-LB-000-D2 don't have 24V logic power input port
Drive 1, Drive 2 share a 24V logic power supply

FD134S-CB-020-D2 drive wiring port description

Bus communication interface

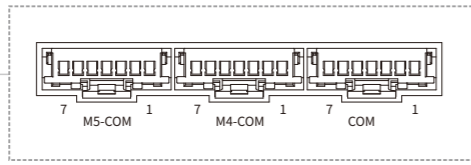

Pin No.	Signal
1	485B
2	485A
3	CANL
4	CANH
5	PE
6	GND
7	+24V~60V

Communication interface RS232

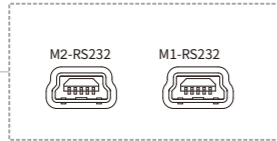

Pin No.	Signal
1	NC
2	RX
3	TX
4	NC
5	GND

Note:
Customers can choose Kinco servo commissioning cable-MINIUSB, model **PDC-USBM-1 (5)**

Motor encoder input interface

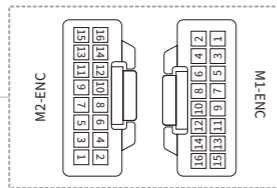

Pin No.	Incremental magnetolectric encoder signal	Magnetolectric encoder signal
1	GND	VDD
2	+5V	\
3	/A	\
4	A	\
5	/B	\
6	B	MA_P+
7	/Z	SLO_P+
8	Z	\
9	/U	GND
10	U	\
11	/V	\
12	V	\
13	/W	\
14	W	MA_N-
15	/	SLO_N-
16	Shield	Shield

FD134S-CB-020-D2 drive wiring port description

Motor encoder input interface

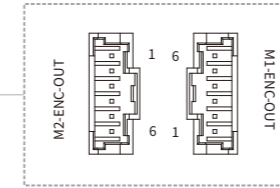

Pin No.	Signal
1	B+
2	B-
3	/
4	/
5	A+
6	A-

Digital signal input port

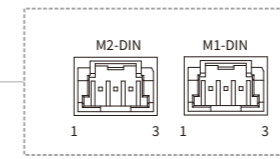

Pin No.	Signal
1	COMI
2	DI1
3	DI2

Note:
Kinco IO accessory kit: **FD134S-020-D2-IO** can be purchased

Input terminal M1-DIN/M2-DIN wiring diagram

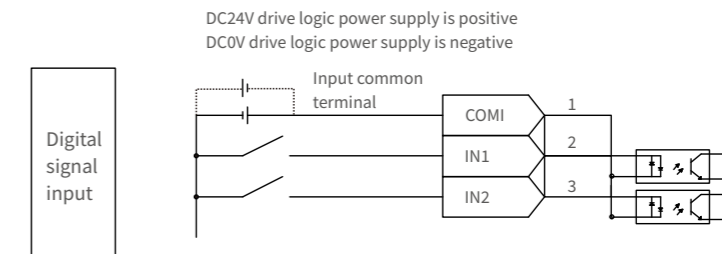

MD series integrated servo motor

Innovative and practical integrated design

Compact structure

The product integrates servo drive and low-voltage servo motor, which is smaller in size and saves equipment installation space.

High reliability

Eliminate the connection line between the motor and the drive, reduce equipment failures caused by connection problems, and reduce the equipment failure rate.

Lower cost

Save connecting cables and effectively reduce equipment cost.



Integrated servo motor naming rules

MD series integrated servo drive model description

Model description: **MD 60- 040 - D M A K - CA - 000**

① ② ③ ④ ⑤ ⑥ ⑦ ⑧ ⑨

①-Series name	MD: Integrated servo motor	⑤-EnCoder type	M: Magnetolectric encoder
②-Flange	60 : 60x60(mm) 80 : 80x80(mm)	⑥- Brake	A : None B : Have
③-Rate power	0020 : 20x10(W) 0040 : 40x10(W) 0075 : 75x10(W)	⑦-Outgoing shaft style	K: Keyed
④-Supply voltage	D: DC48V	⑧ Control mode	LA: RS232, RS485, pulse CA: RS232, CANopen, pulse EA: RS232, EtherCAT PA: RS232, Profinet

⑨ Software version number 000: Software version number

Note: The oil seal is an optional accessory, and it can be omitted if it is not necessary.

MD integrated servo motor technical parameter



Model parameters		MD integrated servo motor		
		MD60-020-DM□K-■A-000	MD60-040-DM□K-■A-000	MD80-075-DM□K-■A-000
Power supply	Power	24VDC-60VDC	24VDC-60VDC	24VDC-60VDC
Current	Rated current (rms)	5Arms	10Arms	20Arms
	Peak current(PEAK)	21Ap	36Ap	80Ap
Brake holding torque T(Nm)		1.5	1.5	3.2
Feedback signal		Magnetolectric encoder		
Energy consumption braking		Need for external braking resistor (depending on the operating conditions, mainly used in the case of rapid start/stop)		
Energy consumption brake voltage absorption point		DC73V ± 2V (default value, settable)		
Overvoltage alarm voltage		DC83V ± 2V		
Undervoltage alarm voltage		DC18V ± 2V		
Cooling method		Natural cooling		
Input specification		4-channel digital input,with COM1 terminal, high level:12.5~30VDC,low level:0~5VDC, max frequency:1KHZ, input impedance:5KΩ		
Output specification		2-channel digital output common COMO terminal Maximum output current: 100mA		
Impulsive control		Pulse+Direction, CCW+CW, Phase A+Phase B (3.3~24V) The input voltage: 3.3V~24V; Maximum frequency: 500KHz (note:MD -060-D MK-EA-000 don't support this function)		
Brake		Built-in brake power supply		
RS232		The default baud rate is 38400bps, and the maximum baud rate is 115.2Kbps. The host computer Kincoservo+		
RS485		Maximum support 115.2Kbps baud rate, can use Modbus RTU protocol to communicate with the controller		
CAN BUS		Maximum support 1Mbps baud rate, can use CANopen protocol to communicate with the controller		
EtherCAT		Support CoE(CIA402 protocol)and CSP/CSV/PP/PV/PT/HM mode, communication speed 100M		
Profinet		Support No. 1 message, No. 3 message, No. 111 message, process object, aperiodic data read and write, etc.		
Rated Speed nN(rpm)		3000		
Rated Torque Tn(Nm)		0.64	1.27	2.39
Rotational inertia Jm (Kg·cm ²)		0.214	0.405	1.087
		0.218 (with brake)	0.409 (with brake)	1.099 (with brake)
Operation environment	Operation temperature	0~40°C		
	Storage temperature	-10°C~70°C		
	Humidity(non-condensing)	Below 90%RH		
	Protection level	Shaft end IP54, protection level IP20		
	Installation environment	Dust-free, dry and lockable (such as electrical cabinets)		
	Installation mode	Vertical or horizontal installation		
	Height	The rated working altitude is below 1000m.When the working altitude is above 1000m, every 100 meters of ascent is required, and the maximum working altitude is 4000 meters above sea level		
Atmospheric pressure		86kpa-106kpa		

Note: ■=L: communication port RS232, RS485, pulse
■=C: Communication port RS232, CANopen, pulse
■=E: Communication port RS232, EtherCAT
■=P: Communication port RS232, Profinet

□=A: without brake
□=B: with brake

MD series mechanical dimension diagram

MD60 mechanical dimension diagram (Unit:mm)

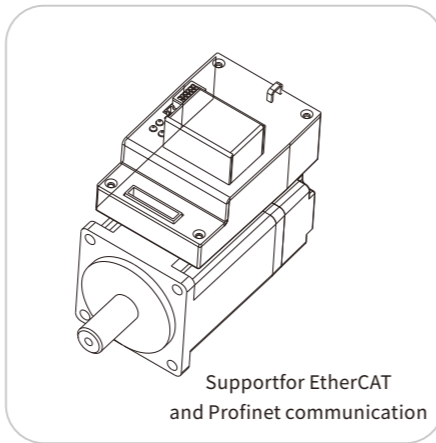
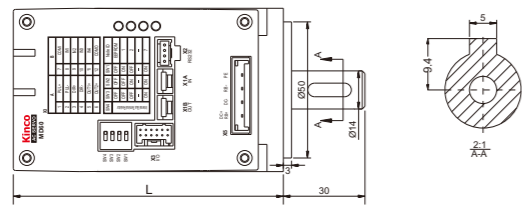
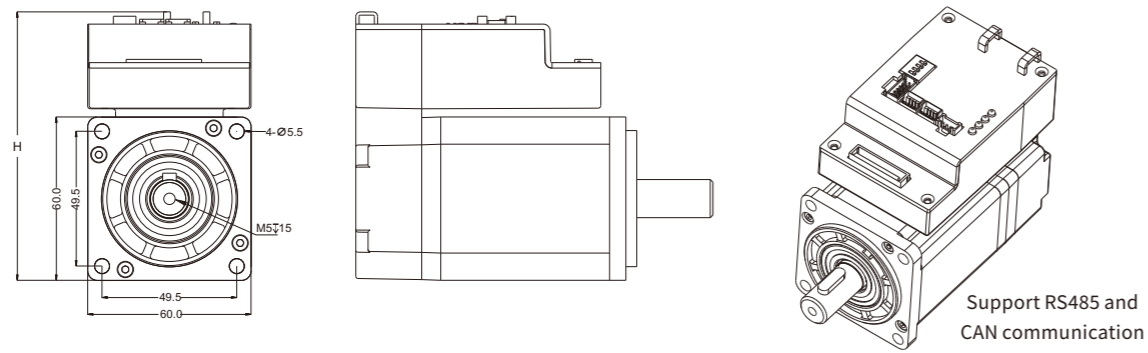

MD60 series models	Brake	Weight (KG)	Machine height H (mm)	Machine dimension L (mm)
MD60-020-DMAK-LA-000		1.2	98.6	99.2±1.5
MD60-020-DMAK-CA-000				
MD60-020-DMAK-EA-000		1.25	113.1	
MD60-020-DMAK-PA-000				129.2±1.5
MD60-020-DMBK-LA-000	✓	1.6	98.6	
MD60-020-DMBK-CA-000				
MD60-020-DMBK-EA-000		1.65	113.1	
MD60-020-DMBK-PA-000				125.2±1.5
MD60-040-DMAK-LA-000		1.6	98.6	
MD60-040-DMAK-CA-000				
MD60-040-DMAK-EA-000		1.65	113.1	
MD60-040-DMAK-PA-000				155.2±1.5
MD60-040-DMBK-LA-000	✓	2	98.6	
MD60-040-DMBK-CA-000				
MD60-040-DMBK-EA-000		2.05	113.1	
MD60-040-DMBK-PA-000				

MD series mechanical dimension diagram

MD80 mechanical dimension diagram (Unit:mm)

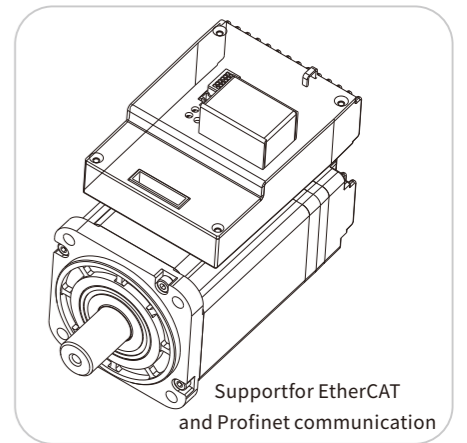
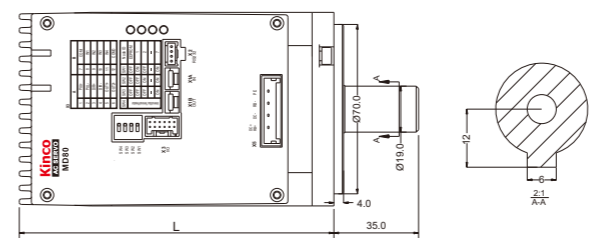
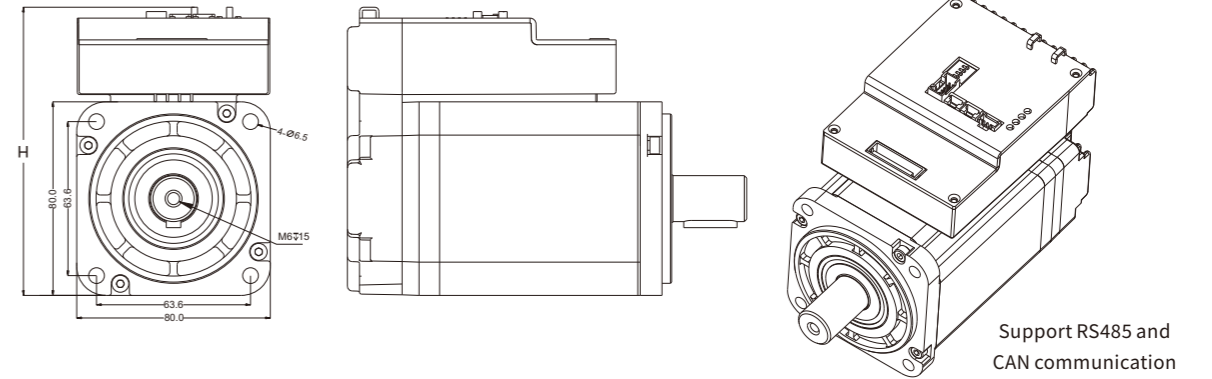

MD80 series models	Brake	Weight (KG)	Machine height H (mm)	Machine dimension L (mm)
MD80-075-DMAK-LA-000		2.9	119.1	130±1.5
MD80-075-DMAK-CA-000				
MD80-075-DMAK-EA-000		2.95	133.6	
MD80-075-DMAK-PA-000				164.2±1.5
MD80-075-DMBK-LA-000	✓	3.5	119.1	
MD80-075-DMBK-CA-000				
MD80-075-DMBK-EA-000		3.55	133.6	
MD80-075-DMBK-PA-000				

MD series terminal description

Bus communication interface

Note: Applicable to MD series models supporting EtherCAT and Profinet communication

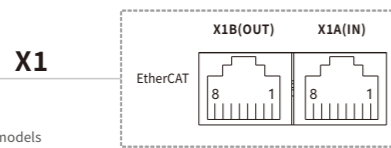

Pin No.	EtherCAT
1	TD+
2	TD-
3	RD+
4	\
5	\
6	RD-
7	\
8	\

Bus communication interface

Note: Applicable to MD series models supporting RS485 and CAN communication

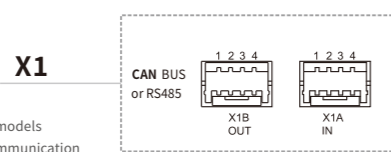

Pin No.	CAN	RS485
1	GND	GND
2	GND	GND
3	CAN_L	485+
4	CAN_H	485-

Note: Kinco communication cable: MD-P4-(8) can be purchased

RS232 communication port

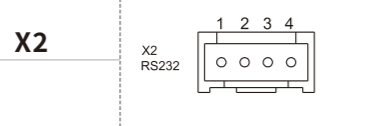

Pin No.	Signal
1	GND
2	GND
3	TX
4	RX

Note: Kinco communication cable: OD124RS232-0.5m can be purchased

Digital signal input/output port

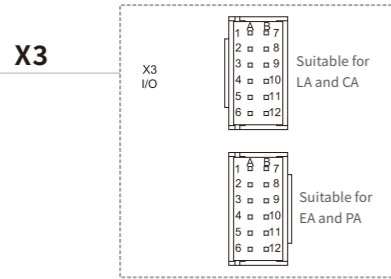

Kinco IO accessory kit can be purchased: MD-IO-12P

A		B	
Pin No.	Signal	Pin No.	Signal
1	PUL+	7	COMI
2	PUL-	8	IN1
3	DIR+	9	IN2
4	DIR-	10	IN3
5	OUT1+	11	IN4
6	OUT2+	12	COMO

Note 1: MD □□□□□□□□ - DM □ K-EA-000 and MD □□□□□□□□ - DM □ K-PA-000 do not support pulse function, Pins 1, 2, 3 and 4 are empty, and the brake models 1, 2, 3, 4 and 6 are empty

X3	PUL+, PUL-, DIR+, DIR-	Pulse signal input terminal Input voltage: 3.3V~24V Maximum frequency: 500KHz
	OUT1+, OUT2+, COMO	Digital signal output terminal Maximum output current: 100mA
	IN1, IN2, IN3, IN4, COMI	Digital signal input terminal High level: 12.5VDC~30VDC Low level: 0VDC~5VDC Input frequency: <1KHz

Power supply external braking resistor

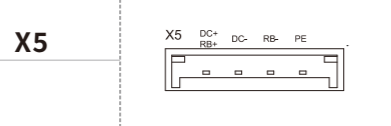

X5	
DC+, DC-	DC power input (24-70V)
PE	Grounding
RB+, RB-	External braking resistor

Input and output terminal wiring diagram (MD series)

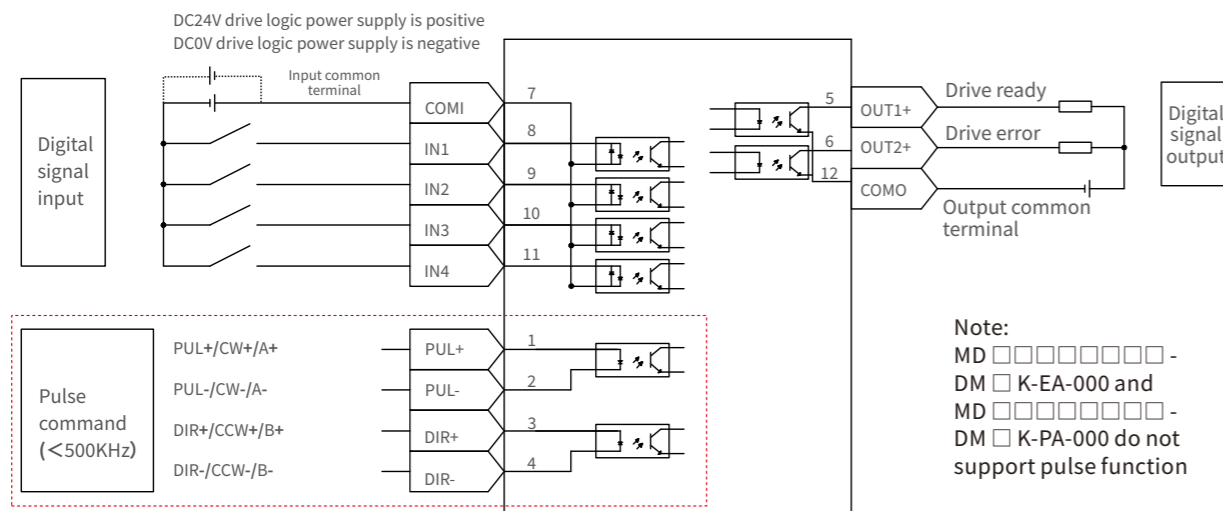

A new generation of G2 series servo motor

New electromagnetic design

The design adopts 12 slots and 10 poles, with small cogging torque and low torque ripple, which is conducive to reducing vibration during motor operation and making torque output more stable.

New structure and short fuselage

The fuselage structure is redesigned and the length of the fuselage is shortened, which can save more installation space for customer equipment and reduce equipment size.

The latest magnetolectric coding technology

The independently designed magnetolectric encoder has good shock resistance and high cost performance.

Insulation class F

The motor is at the highest level of insulation in the industry, and it can maintain high reliability and stability in high temperature extreme environments.

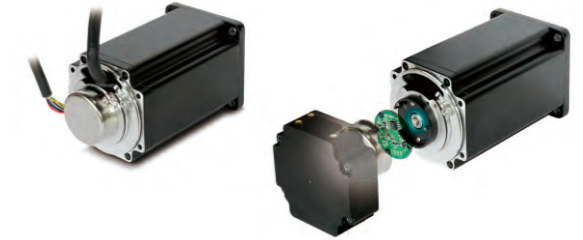

Model description / model list

model: **SMC 60 S - 0040 - 30 M A K - 5 D S U**

① ② ③ ④ ⑤ ⑥ ⑦ ⑧ ⑨ ⑩ ⑪ ⑫

①-Series name	SMH : SMH series SMC : SMC series	⑥-Encoder type	M: Singleturn communication magnetolectric encoder Q: Multiturn communication magnetolectric encoder A : 2500P/R photoelectric incremental encoder W: 2500P/R incremental magnetolectric encoder
②-Flange	40: 40x40(mm) 60: 60x60(mm) 80: 80x80(mm) 110: 110x110(mm) 130: 130x130(mm)	⑦-Brake	A : None B : Have
③-Inertia type	S: Small inertia D: Medium inertia	⑧-Output shaft style	K: With key
④-Rated power	0005:5x10(W) 0010:10x10(W) 0020:20x10(W) 0040:40x10(W) 0060:60x10(W) 0075:75x10(W) 0100:100x10(W) 0120:120x10(W) 0150:150x10(W) 0250:250x10(W) 0300:300x10(W)	⑨-Number of polar pairs	4:4 pole pairs 5:5 pole pairs
		⑩-Supply voltage	D: DC48V
		⑪-Motor version number	K: K version S: S version C: Ultra short version
⑤-Rated rotation speed	20:20x100(rpm) 30:30x100(rpm)	⑫-Motor outlet mode	H : Three rows of 15-pin metal shell encoder socket U : Communication encoder socket R : Aviation socket

Note: The oil seal is an optional accessory, and it can be omitted if it is not necessary.

Low-voltage servo motor specification model table (DC48V)

Flange dimension (mm)	Servo motor model	Encoder type	Rotational inertia Jm(Kg·cm ²)	Rated power Pn(W)	Rated torque Tn(Nm)	Rated current In(A)	Rated rotation speed nN(rpm)
40x40	SMC40S-0005-30M□K-5DSU	Magnetolectric encoder	0.018 (0.021)	50	0.16	1.5	3000
	SMC40S-0005-30Q□K-5DSU	Multiturn magnetolectric absolute value encoder	0.033 (0.036)				
	SMC40S-0010-30M□K-5DSU	Magnetolectric encoder		100	0.32	3.2	
	SMC40S-0010-30Q□K-5DSU	Multiturn magnetolectric absolute value encoder					
60x60	SMC60S-0020-30M□K-5DSU	Magnetolectric encoder	0.2 (0.204)	200	0.64	5.7	
	SMC60S-0020-30Q□K-5DSU	Multiturn magnetolectric absolute value encoder					
	SMC60S-0020-30A□K-5DSH	2500P/R Photoelectric encoder	0.11(0.114)				
	SMC60S-0020-30W□K-5DCH	2500P/R incremental magnetolectric encoder motor					
	SMC60S-0040-30M□K-5DSU	Magnetolectric encoder	0.38 (0.384)	400	1.27	10.6	
	SMC60S-0040-30Q□K-5DSU	Multiturn magnetolectric absolute value encoder					
	SMC60S-0040-30A□K-5DSH	2500P/R Photoelectric encoder	0.26 (0.264)				
	SMC60S-0040-30W□K-5DCH	2500P/R incremental magnetolectric encoder motor					
	80x80	SMC60S-0060-30M□K-5DSU	Magnetolectric encoder	0.65 (0.654)	600	1.91	16.5
		SMC60S-0060-30Q□K-5DSU	Multiturn magnetolectric absolute value encoder				
		SMC60S-0060-30A□K-5DSH	2500P/R Photoelectric encoder	1.027(1.099)	750	2.39	19.9
		SMC80S-0075-30M□K-5DSU	Magnetolectric encoder				
SMC80S-0075-30Q□K-5DSU		Multiturn magnetolectric absolute value encoder	0.77(0.84)				
SMC80S-0075-30A□K-5DSH		2500P/R Photoelectric encoder					
SMC80S-0075-30W□K-5DCH		2500P/R incremental magnetolectric encoder motor	1.36(1.41)	1000	3.18	26.4	
SMC80S-0100-30M□K-5DSU		Magnetolectric encoder					
SMC80S-0100-30Q□K-5DSU		Multiturn magnetolectric absolute value encoder	1.027(1.099)				
SMC80S-0100-30A□K-5DSH		2500P/R Photoelectric encoder					
110x110		SMC80S-0100-30W□K-5DCH	2500P/R incremental magnetolectric encoder motor	1.36(1.41)	1200	3.82	34
		SMC80S-0120-30A□K-5DSH	2500P/R Photoelectric encoder	5.8(6.1)			
	SMH110D-0120-30A□K-4DKR	2500P/R Photoelectric encoder	7.4(7.5)	1200	3.8	31.6	
	SMC130D-0120-30A□K-4DKR	2500P/R Photoelectric encoder	12(12.1)				
130x130	SMC130D-0150-30A□K-4DKR	2500P/R Photoelectric encoder	11.5(11.5)	1500	5	37.5	
	SMC130D-0150-30W□K-4DSH-2	2500P/R Photoelectric encoder	17.1(17.1)				
	SMC130D-0250-30W□K-4DSH-2	2500P/R Photoelectric encoder	22.6(22.6)	3000	9.55	72	
	SMC130D-0300-30W□K-4DSH-2	2500P/R Photoelectric encoder	35.9(35.9)				
	SMC130D-0300-20W□K-4DSH-2	2500P/R incremental magnetolectric encoder motor	3000	14.3	77.7	2000	

Note 1: Operating environment

Temperature: -20~40°C (no freezing)

Humidity: below 90%RH (no condensation)

Environment: keep away from corrosion, flammable gases, oil droplets, dust

Altitude: 1000~4000m, every 100m increase, power decreases by 1.5%

Protection class: (1) body IP65, shaft end (without oil seal) IP54 Shaft end installation oil seal IP65

(2) for oil seal installation, please refer to the product instruction manual

Energy efficiency class: class 2

Note 2: □=A: Without brake

□=B: With brake

Note 3: The values in parentheses in the moment of inertia column are the values of the moment of inertia column of the brake motor

Dimension drawing of G2 series servo motors (short body, DC48V)

40 Flange

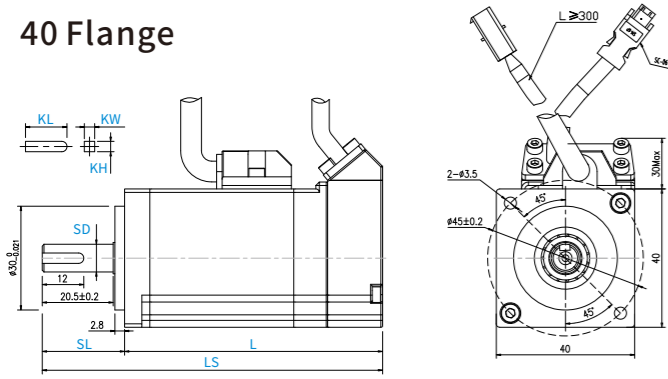

40 Flange (Brake)

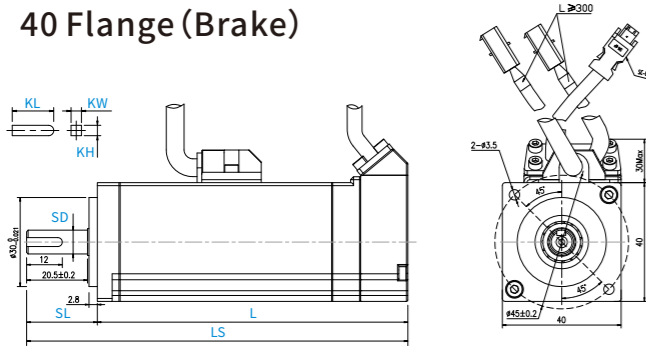

Flange dimension (mm)	Servo motor	Brake	Weight (KG)	Overall dimension (mm)		Shaft dimension (mm)			Key dimension (mm)		
				LS	L	SL	SD	Screw hole x depth	KL	KW	KH
40x40	SMC40S-0005-30MAK-5DSU		0.4	98.4±1.5	74.6±1.5	23.8±0.8	8	M3x6	12	3	3
	SMC40S-0005-30QAK-5DSU			98±1.5	74.2±1.5						
	SMC40S-0005-30MBK-5DSU	✓	0.6	128.4±1.5	104.6±1.5						
	SMC40S-0005-30QBK-5DSU			128±1.5	104.2±1.5						
	SMC40S-0010-30MAK-5DSU		0.57	120.4±1.5	96.6±1.5						
	SMC40S-0010-30QAK-5DSU			120±1.5	96.2±1.5						
	SMC40S-0010-30MBK-5DSU	✓	0.77	150.4±1.5	126.6±1.5						
	SMC40S-0010-30QBK-5DSU			150±1.5	126.2±1.5						

50W

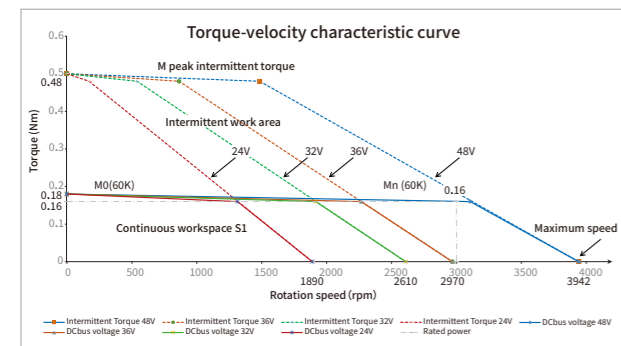

100W

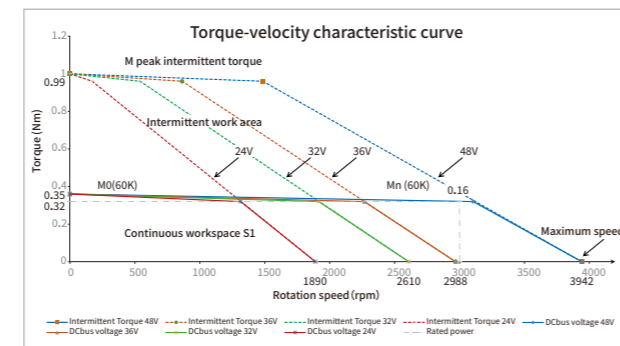

Dimension drawing of G2 series servo motors (short body, DC48V)

60 Flange

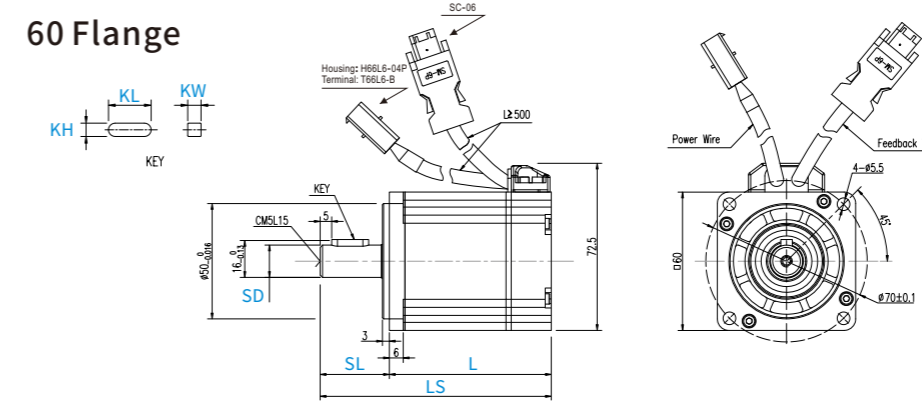

60 Flange (Brake)

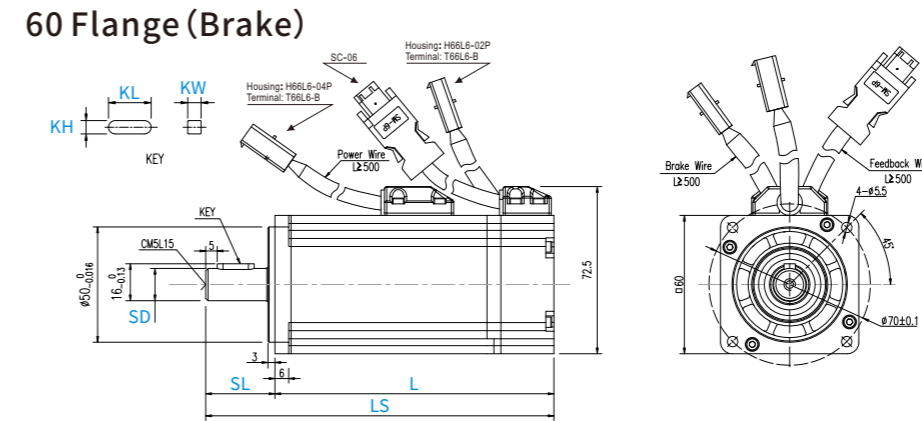

Flange dimension (mm)	Servo motor	Brake	Weight (KG)	Overall dimension (mm)		Shaft dimension (mm)			Key dimension (mm)		
				LS	L	SL	SD	Screw hole x depth	KL	KW	KH
60x60	SMC60S-0020-30MAK-5DSU		0.9	105±1.5	75±1.5	30±1	14	M5x15	16	5	5
	SMC60S-0020-30QAK-5DSU			105±1.5	75±1.5						
	SMC60S-0020-30AAK-5DSH			116.5±1.5	86.5±1.5						
	SMC60S-0020-30WAK-5DCH		0.6	81.5±1.5	51.5±1.5						
	SMC60S-0020-30MBK-5DSU			142.5±1.5	112.5±1.5						
	SMC60S-0020-30QBK-5DSU	✓		152.5±1.5	122.5±1.5						
	SMC60S-0020-30ABK-5DSH		1.2	114±1.5	84±1.5						
	SMC60S-0020-30WBK-5DCH			127±1.5	97±1.5						
	SMC60S-0040-30MAK-5DSU			138.5±1.5	108.5±1.5						
	SMC60S-0040-30QAK-5DSU		1.2	101.5±1.5	71.5±1.5						
	SMC60S-0040-30AAK-5DSH			164.5±1.5	134.5±1.5						
	SMC60S-0040-30WAK-5DCH	✓		174±1.5	144±1.5						
	SMC60S-0040-30MBK-5DSU		1.6	134±1.5	104±1.5						
	SMC60S-0040-30QBK-5DSU			167.5±1.5	132.5±1.5						
	SMC60S-0060-30MAK-5DSU			174±1.5	144±1.5						
	SMC60S-0060-30QAK-5DSU		1.9	197.5±1.5	167.5±1.5						
	SMC60S-0060-30AAK-5DSH			207±1.5	177±1.5						
	SMC60S-0060-30WBK-5DCH	✓									
SMC60S-0060-30ABK-5DSH											

200W

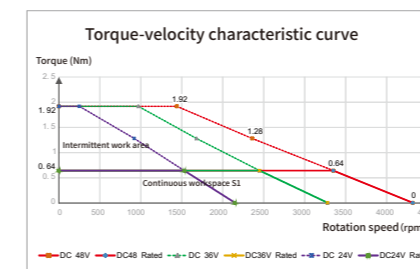

400W

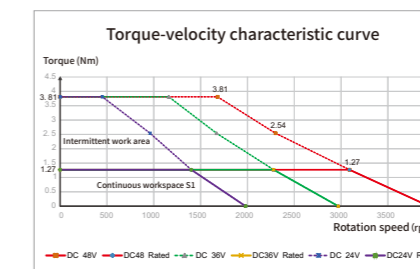

600W

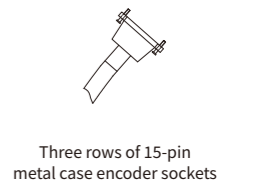
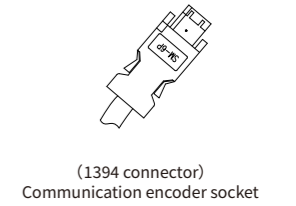
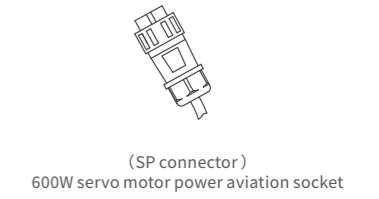
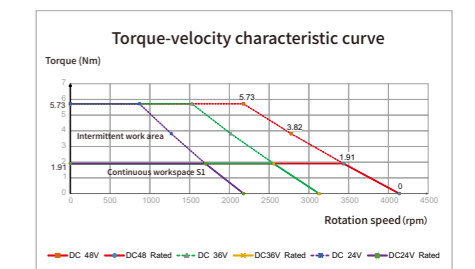

Dimension drawing of G2 series servo motors (short body, DC48V)

80 Flange

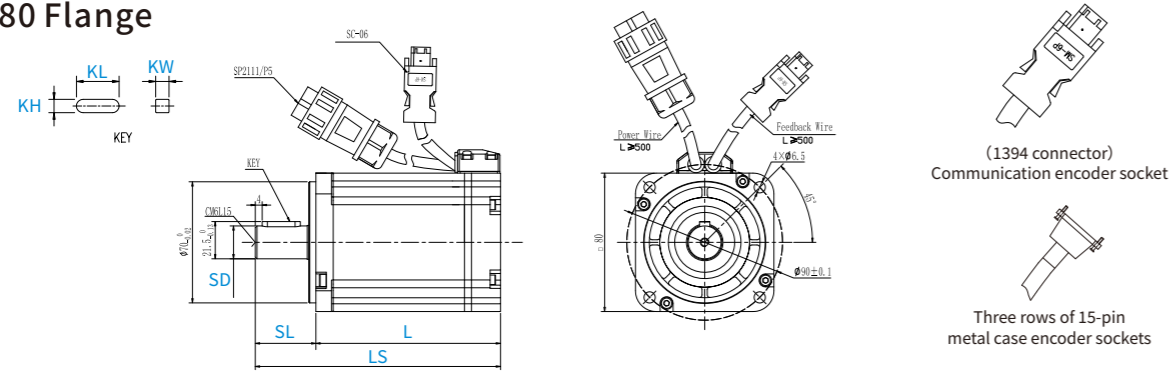

80 Flange (Brake)

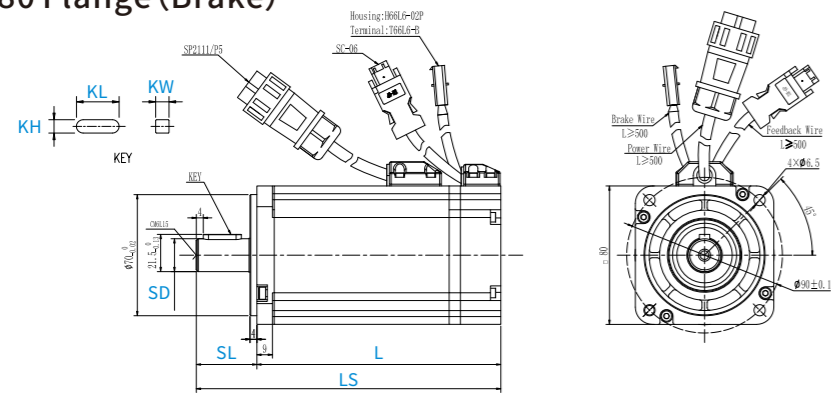

Flange dimension (mm)	Servo motor	Brake	Weight (KG)	Overall dimension (mm)		Shaft dimension (mm)			Key dimension (mm)			
				LS	L	SL	SD	Screw hole x depth	KL	KW	KH	
80x80	SMC80S-0075-30MAK-5DSU		2.3	141.7±1.5	106.7±1.5							
	SMC80S-0075-30QAK-5DSU		2.5	153.2±1.5	118.2±1.5							
	SMC80S-0075-30AAK-5DSH		2.4	153.2±1.5	118.2±1.5							
	SMC80S-0075-30WAK-5DCH		1.8	118.5±1.5	83.5±1.5							
	SMC80S-0075-30MBK-5DSU		3	176±1.5	141±1.5							
	SMC80S-0075-30QBK-5DSU	✓	3	176±1.5	141±1.5							
	SMC80S-0075-30ABK-5DSH	✓	3.2	185±1.5	150±1.5							
	SMC80S-0075-30WBK-5DCH		2.9	151.9±1.5	116.9±1.5							
	SMC80S-0100-30MAK-5DSU		2.8	157.7±1.5	122.7±1.5	35±1	19	M6x15	22	6	6	
	SMC80S-0100-30QAK-5DSU		3	169.2±1.5	134.2±1.5							
	SMC80S-0100-30AAK-5DSH		2.2	130.5±1.5	95.5±1.5							
	SMC80S-0100-30WAK-5DCH		2.2	130.5±1.5	95.5±1.5							
	SMC80S-0100-30MBK-5DSU		3.3	192±1.5	157±1.5							
	SMC80S-0100-30QBK-5DSU	✓	3.3	192±1.5	157±1.5							
	SMC80S-0100-30ABK-5DSH	✓	3.6	201±1.5	166±1.5							
	SMC80S-0100-30WBK-5DCH		3	163.9±1.5	128.9±1.5							
	SMC80S-0120-30AAK-5DSH		2.8	169±1.5	134.2±1.5							
	SMC80S-0120-30ABK-5DSH	✓	3.3	201±1.5	166±1.5							

750W

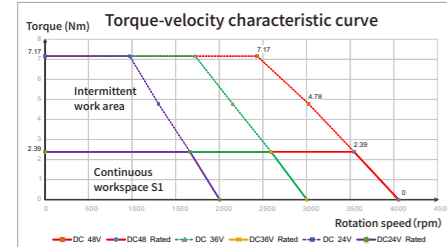

1000W

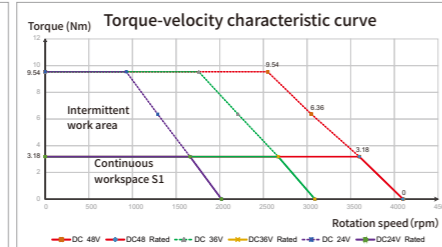

1200W

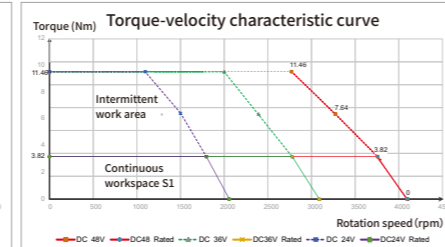

Dimension drawing of 110 series servo motors (DC48V)

110 Flange

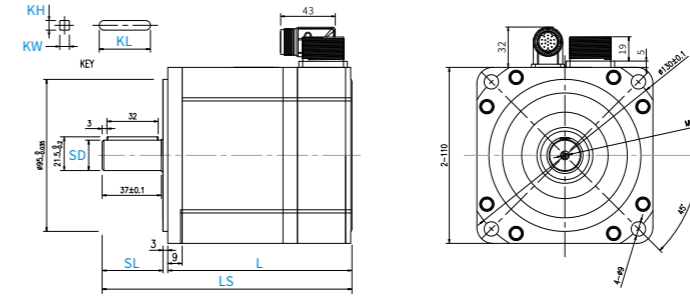

110 Flange (Brake)

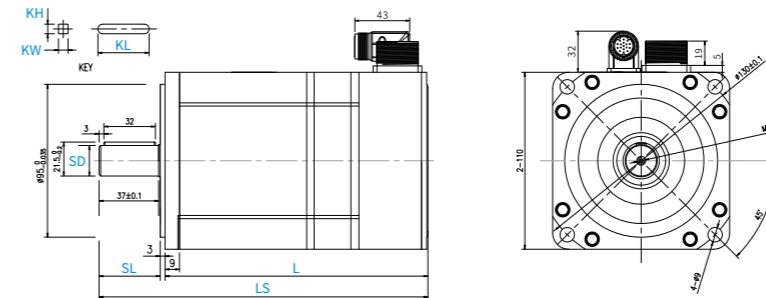

Flange dimension (mm)	Servo motor	Brake	Weight (KG)	Overall dimension (mm)		Shaft dimension (mm)			Key dimension (mm)		
				LS	L	SL	SD	Screw hole x depth	KL	KW	KH
110x110	SMH110D-0120-30AAK-4DKR		6.2	206±1.5	168±1.5	38±1	19	M6x18	32	6	6
	SMH110D-0120-30ABK-4DKR	✓	7.2	266±1.5	228±1.5	38±1	19	M6x18	32	6	6

Note: The minimum installation size shall refer to the MOT-040-LL-KC5 slot height of the power cable

1.2kW

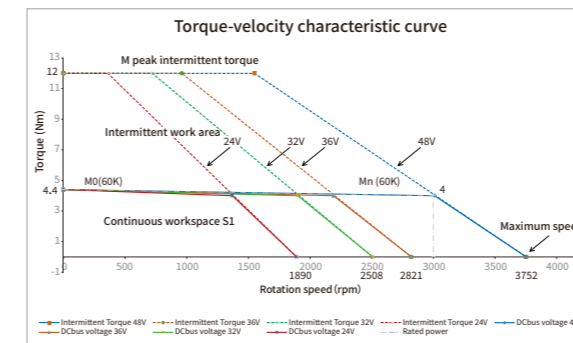

**Dimension drawing of 130 series servo motors
(DC48V incremental photoelectric encoder)**

130 Flange

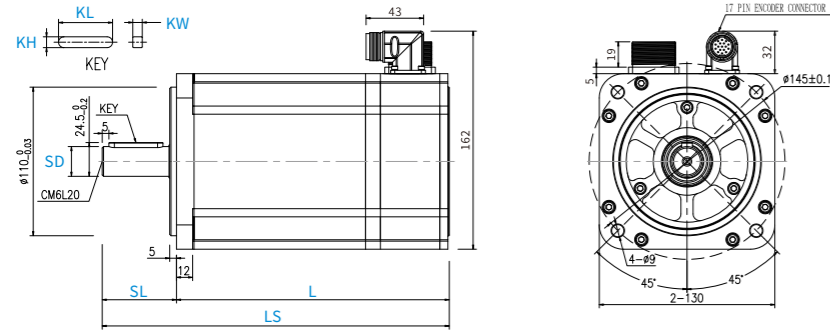

130 Flange (Brake)

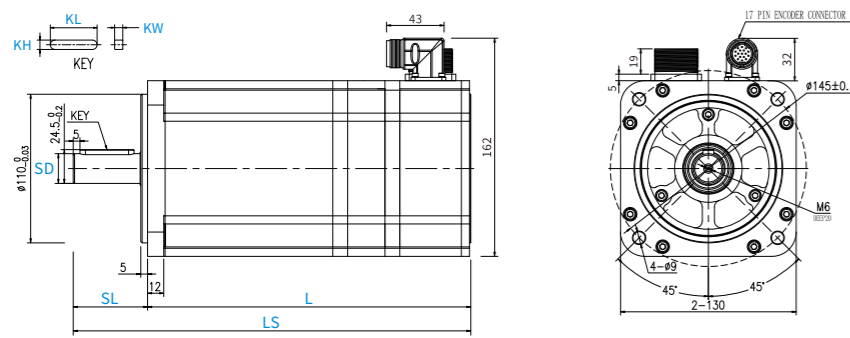

Flange dimension (mm)	Servo motor	Brake	Weight (KG)	Overall dimension (mm)		Shaft dimension (mm)			Key dimension (mm)		
				LS	L	SL	SD	Screw hole x depth	KL	KW	KH
130x130	SMC130D-0120-30AAK-4DKR		6.2	202±1.5	147±1.5	55±1	22	M6x18	40	6	6
	SMC130D-0120-30ABK-4DKR	✓	8.5	263±1.5	208±1.5						
	SMC130D-0150-30AAK-4DKR		7.5	218±1.5	163±1.5						
	SMC130D-0150-30ABK-4DKR		9.8	279±1.5	224±1.5						
	SMC130D-0150-30ABK-4DKR	✓	9.8	279±1.5	224±1.5						

Note: The minimum installation size shall refer to the MOT-040-LL-KC5 slot height of the power cable

1.2kW

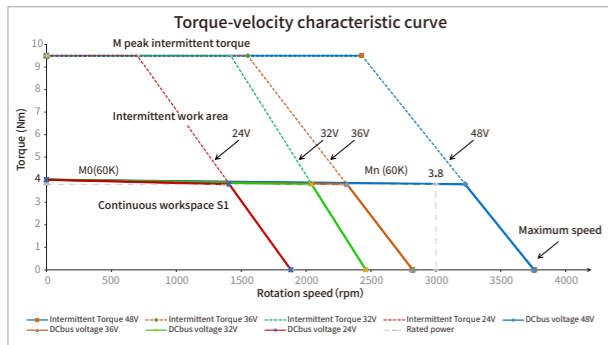

1.5kW

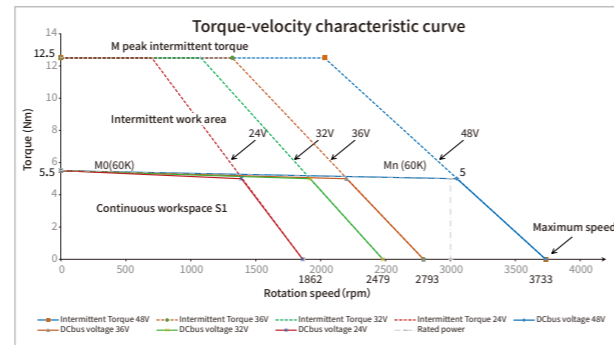

**Dimension drawing of 130 series servo motors
(DC48V incremental photoelectric encoder)**

130 Flange (incremental magnetolectric encoder)

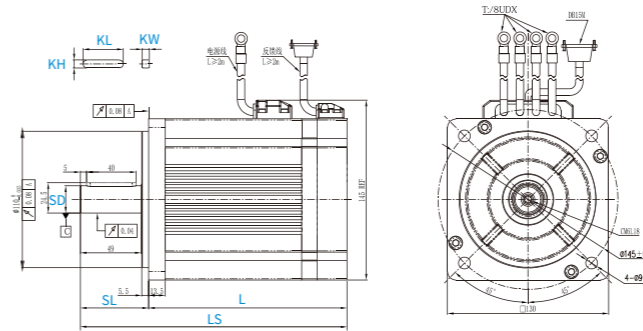

130 Flange (incremental magnetolectric encoder)(brake)

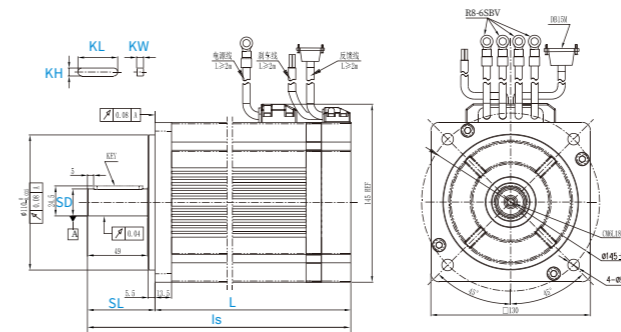

Flange dimension (mm)	Servo motor	Brake	Weight (KG)	Overall dimension (mm)		Shaft dimension (mm)			Key dimension (mm)		
				LS	L	SL	SD	Screw hole x depth	KL	KW	KH
130x130	SMC130D-0150-30WAK-4DSH-2		6.1	195±1.5	140±1.5	55±1	22	M6x18	40	6	6
	SMC130D-0150-30WBK-4DSH-2	✓	8	211±1.5	156±1.5						
	SMC130D-0250-30WAK-4DSH-2		7.6	215±1.5	160±1.5						
	SMC130D-0250-30WBK-4DSH-2	✓	9.6	231±1.5	176±1.5						
	SMC130D-0300-30WAK-4DSH-2		9	235±1.5	180±1.5						
	SMC130D-0300-30WBK-4DSH-2	✓	11	251±1.5	196±1.5						
	SMC130D-0300-20WAK-4DSH-2		11.9	275±1.5	220±1.5						
	SMC130D-0300-20WBK-4DSH-2	✓	14.3	291±1.5	236±1.5						

1.5kW

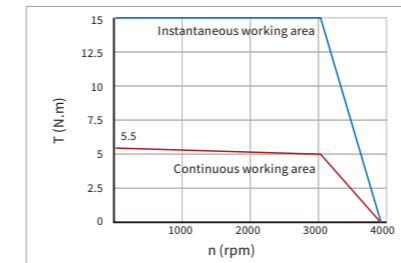

2.5kW

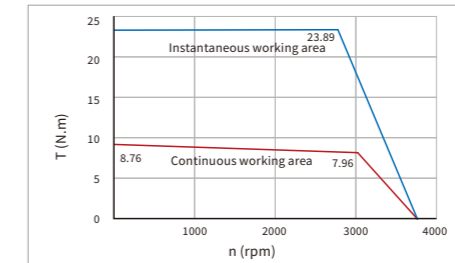

3kW(3000rpm)

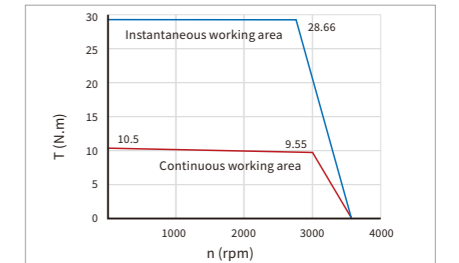

3kW(2000rpm)

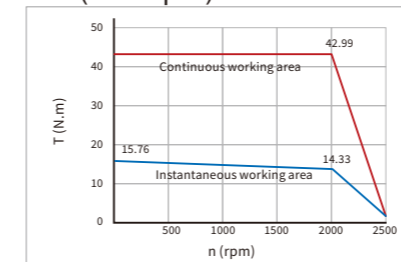

Naming rules for motor cables

Power cable: **MOT F - 005-03 - KL - D**

① ② ③ ④ ⑤ ⑥

①-Cable function type	MOT: Motor power cable	④-Cable length	(5): 0.5 m 01: 1 m 02: 2 m 03: 3 m
②-Cable type	F: The flexible cable Empty: Ordinary cable	⑤-Outgoing type of motor	KL: 4PIN power plug KC5: Aviation socket
③-Rated current	005:5A 008:8A 020:20A 030:30A 040:40A	⑥-Connector types	D: DC servo standard connector SP: SP21 series common aviation plugs B: brake - power integrated cable Empty: Ordinary cable

Encoder cable: **ENC H G F - 03 - G U - □ □**

① ② ③ ④ ⑤ ⑥ ⑦ ⑧

①-Cable function type	ENC: Motor encoder wire	⑤-Cable length	(5): 0.5 m 01: 1 m 02: 2 m 03: 3 m
②-Drive encoder interface type	H: Three rows of 15 pin connector D: 1394 connector O: Compact quick lock connector	⑥-Conductor type	K: 16 core G: 6 core
③-Drive interface definition	A: Incremental encoder G: Communication encoder	⑦-Type of motor end encoder connector	U: 1394 connector C0: HFO series common air connector H: Three rows of 15-pin D-Sub encoder connector
④-Cable type	F: The flexible cable Empty: Ordinary cable	⑧-Cable accessories	DC: With battery (suitable for multi-turn absolute value encoder motors) Empty: No battery

Brake cable: **BRA F - 03 - KL**

① ② ③ ④

①-Cable function type	BRA: Motor brake cable	③-Cable length	(5): 0.5 m 01: 1 m 02: 2 m 03: 3 m
②-Cable type	F: The flexible cable Empty: Ordinary cable	④-Connector types	KL: 2PIN brake connector

Cable(encoder cable)

MOTF-(2)-M

Wire spec: 4x16AWG,drag chain 500 million times
16AWG cross sectional area 1.318mm²

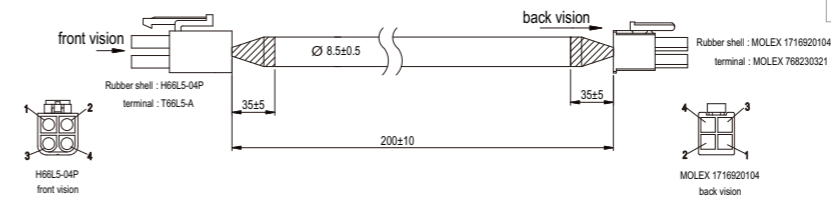

MOTF-(2)-M			
H66L5-04P	Color	Signal	MOLEX 1716920104
PIN1	white	U	PIN1
PIN2	Black	W	PIN2
PIN3	Red	V	PIN3
PIN4	Yellowgreen+Shielding	PE	PIN4

MOT-005-LL-KL-D

Wire spec: 4C×18AWG(41/0.16T)-PVC
18AWG cross sectional area 0.8107mm²

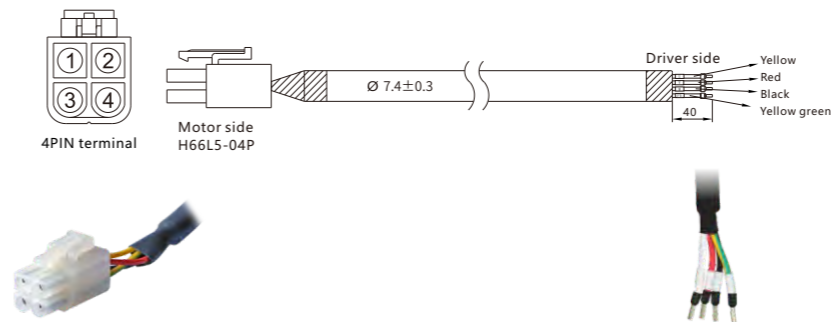

MOT-005-LL-KL-D		
Color	Signal	4PIN plug
white	U	PIN1
Red	V	PIN2
Black	W	PIN3
Yellow green	PE	PIN4

Corresponding accessory: MOT-KL

Corresponding flexible cable **MOTF-005-LL-KL-D**
Wire specification: 4C×18AWG(7/18/0.10T) 500 million times
Wire diameter: 7.3±0.5mm

MOT-008-LL-KL-D

Wire spec: 4×16AWG
16AWG cross sectional area 1.318mm²

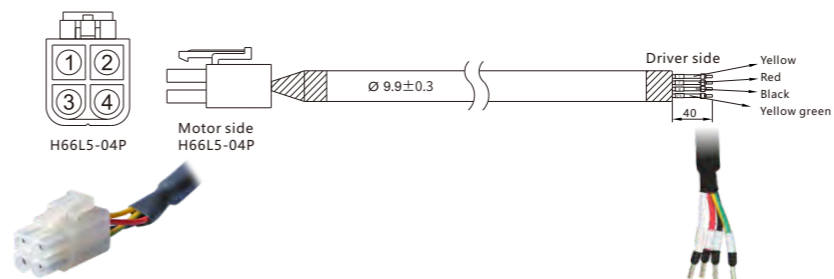

MOT-008-LL-KL-D		
Color	Signal	H66L5-04P
white	U	PIN1
Red	V	PIN2
Black	W	PIN3
Yellow green	PE	PIN4

Corresponding accessory: MOT-KL

Corresponding flexible cable **MOTF-008-LL-KL-D**
Wire specification: 4×1.5mm², BLACK
Wire diameter: 9.3±0.5mm

Cable (power cable)

MOT-020-LL-KL-SP

Wire specification: UL2586 4x13AWG standard cable
13AWG corresponds to a cross-sectional area of 2.627mm²

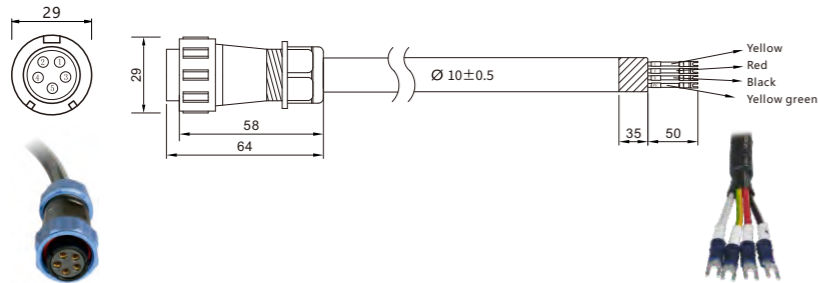

MOT-020-LL-KL-SP		
Color	Signal	5PIN Air insertion
white	U	PIN1
Red	V	PIN2
Black	W	PIN3
Yellow green	PE+Shielding	PIN4
NC	NC	PIN5

Note: Corresponding kit MOT-020-KL-SP
Corresponding flexible cable **MOTF-020-LL-KL-SP**
Wire specification: UL2586 4x13AWG flexible drag chain cable
Wire diameter: 10±0.5mm

MOT-020-LL-KL-SP-1

Wire specification: UL2586 4x13AWG standard cable
13AWG corresponds to a cross-sectional area of 2.627mm²

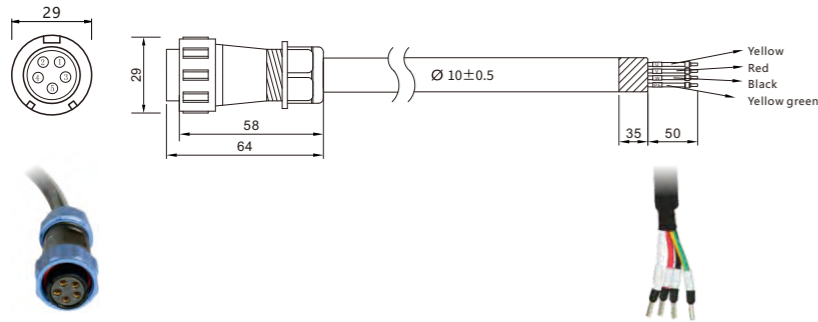

MOT-020-LL-KL-SP-1		
Color	Signal	5PIN Air insertion
white	U	PIN1
Red	V	PIN2
Black	W	PIN3
Yellow green	PE+Shielding	PIN4
NC	NC	PIN5

Note: Corresponding kit MOT-020-KL-SP
Corresponding flexible cable **MOTF-020-LL-KL-SP-1**
Wire specification: UL2586 4x13AWG flexible drag chain cable
Wire diameter: 10±0.5mm

MOTF-030-LL-KL-SP

Wire spec: UL2261 4x12AWG(5 million times)
12AWG cross sectional area 3.332mm²

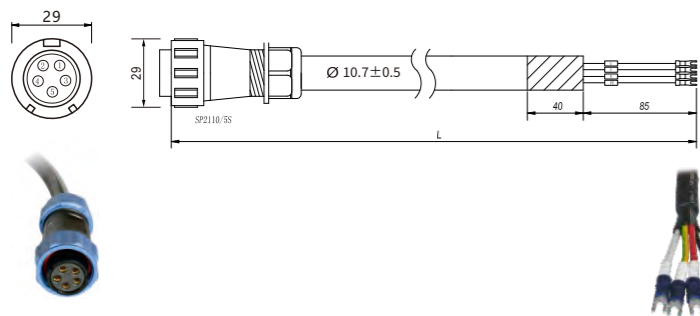

MOTF-030-LL-KL-SP		
Color	Signal	5PIN Air insertion
white	U	PIN1
Red	V	PIN2
Black	W	PIN3
Yellowgreen+Shielding	PE+Shielding	PIN4
NC	NC	PIN5

Cable (power cable/encoder cable)

MOT-040-LL-KC5

Wire spec: 3cx10AWG+3X19AGW
10AWG cross sectional area 5.26mm²
19AWG cross sectional area 0.5667mm²

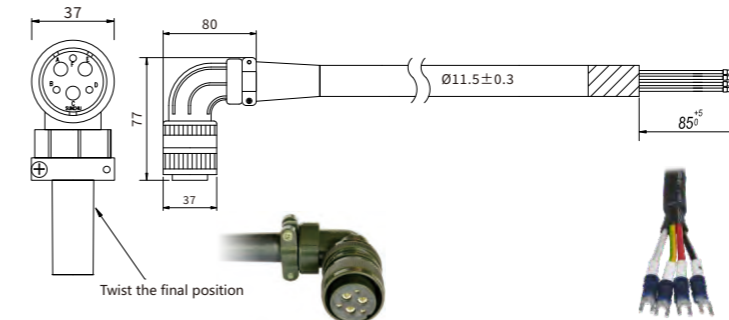

MOT-040-LL-KC5		
Color	Signal	Air insertion
white	U	PINA
Red	V	PINE
Green	W	PINC
Yellow green	PE	PINF
Shielding wire	Shielding	Metal ring

Corresponding accessory: MOT-KC5-B

MOT-040-LL-KC5-B

Wire spec: 3cx10AWG+3X19AGW
10AWG cross sectional area 5.26mm²
19AWG cross sectional area 0.5667mm²

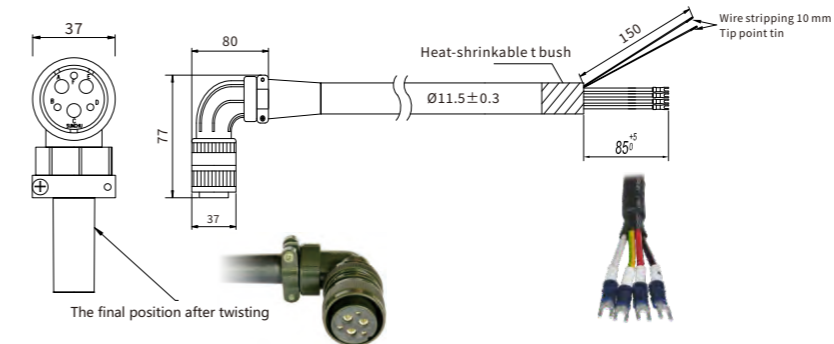

MOT-040-LL-KC5-B		
Color	Signal	Air insertion
white	U	PINA
Red	V	PINE
Black	W	PINC
Yellowgreen	PE	PINF
Red	Brake+	PINB
Blue	Brake-	PIND
shielding	shielding	Shell

Corresponding accessory: MOT-KC5-B

Cable (encoder cable)

ENCDG-LL-GU

Wire spec: 1P*20AWG(26/0.16T)+2P*24AWG(11/0.16T) (OD 7.4mm)
20AWG cross sectional area 0.5189mm²
24AWG cross sectional area 0.2047mm²

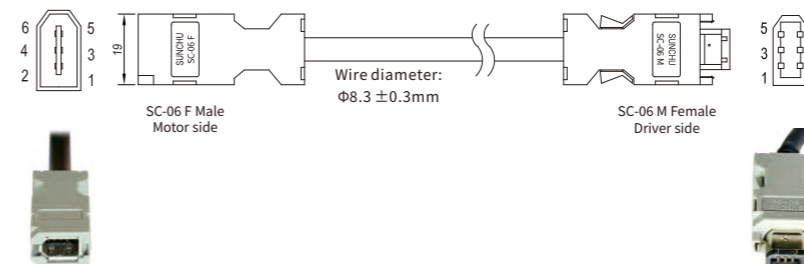

ENCDG-LL-GU			
Color	SC-06	Signal1	Signal 2
Red	PIN1	VDD	+5V
Black	PIN2	GND	GND
Brown	PIN3	MA_P+	BAT+
Blue	PIN4	MA_N-	BAT-
Yellow	PIN5	SLO_P+	SD
Green	PIN6	SLO_N-	/SD
Shielded wire	Shell	Shielding	Shielding

Note: Signal 1 for magnetolectric encoders,
signal 2 for absolute value encoders.
Corresponding accessory: ENCDG-GU

corresponding flexible cable **ENCDGF-LL-GU**
Wire specification: 1P*20AWG(72/0.10T)+2P*24AWG(32/0.10T)
5 million times (OD 7.4mm)
Wire diameter: 7.4±0.5mm

Cable (encoder cable)

ENCHG-LL-GU

Wire spec: 1P*20AWG(26/0.16T)+2P*24AWG(11/0.16T) (OD 7.4mm)
20AWG cross sectional area 0.5189mm²
24AWG cross sectional area 0.2047mm²

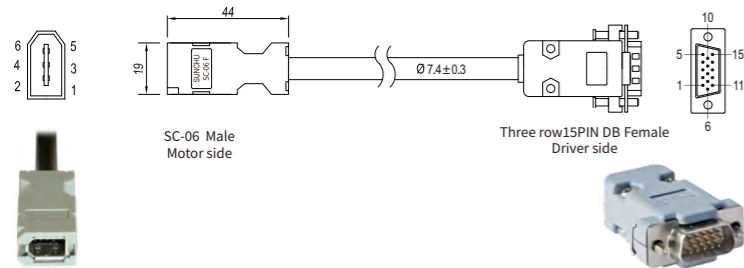

ENCHG-LL-GU				
SC-06F	Color	Signal 1	Signal 2	DB 15 公
PIN1	Red	VDD	VDD	PIN1
PIN2	Black	GND	GND	PIN2
PIN3	Brown	MA_P+		PIN10
PIN4	Blue	MA_N-		PIN15
PIN5	Yellow	SLO_P+	SD	PIN9
PIN6	Green	SLO_N-	/SD	PIN14
Shell	Shielded wire	Shielding	Shielding	Shell

Note: Signal 1 for magnetolectric encoders,
signal 2 for absolute value encoders.
Corresponding accessory: ENCDG-GU

corresponding flexible cable **ENCHGF-LL-GU**
Wire specification: 1P*20AWG(72/0.10T)+2P*24AWG(32/0.10T)
5 million times (OD 7.4mm)
Wire diameter: 7.4 ± 0.5mm

ENCHG-(4)-GU-DC

Wire spec: 3×2×0.2mm²

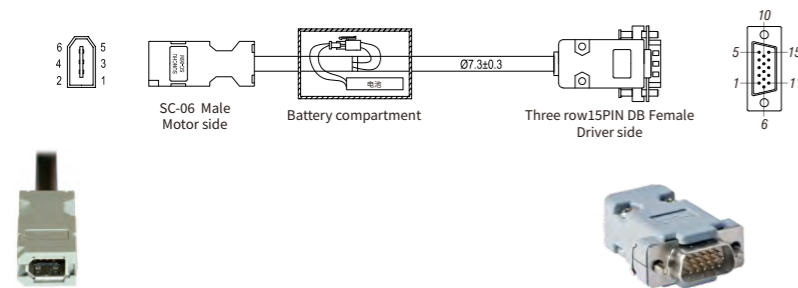

ENCHG-(4)-GU-DC					
SC-06F	Color	Black HSG	External single wire	Signal	DB15 Female
PIN1	Red			+5V	PIN1
PIN2	Black			GND	PIN2
PIN3	Brown	PIN1	Red	BAT+	
PIN4	Blue	PIN2	Black	BAT-	
PIN5	Yellow			SD	PIN9
PIN6	Green			/SD	PIN14
Shell	Shielded wire			Shielding	Shell

ENCOG-LL-GU

Wire spec: 3×2×0.2mm²

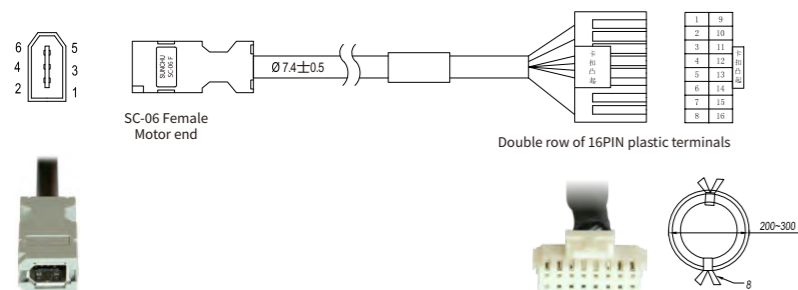

ENCOG-LL-GU				
SC-06	Color	Signal 1	Signal 2	Double row of 16PIN 16PIN
PIN1	Red	VDD	VDD	PIN1
PIN2	Black	GND	GND	PIN9
PIN3	Brown	MA_P+	BAT+	PIN6
PIN4	Blue	MA_N-	BAT-	PIN14
PIN5	Yellow	SLO_P+	SD	PIN7
PIN6	Green	SLO_N-	/SD	PIN15
Shell	Shielded wire	Shielding	Shielding	PIN16

Note: Signal 1 for magnetolectric encoders,
signal 2 for absolute value encoders.
Corresponding accessory package: ENCOG-GU

corresponding flexible cable **ENCOGF-LL-GU**
Wire specification: 1P×22AWG+2P×26AWG 5 million times
Wire diameter: 7.4 ± 0.5mm

Cable(encoder cable/brake cable)

ENCHA-LL-KH

Wire spec: 24AWG/1P+28AWG/7P+AB 1061
24AWG cross sectional area 0.2047mm²
28AWG cross sectional area 0.0804mm²

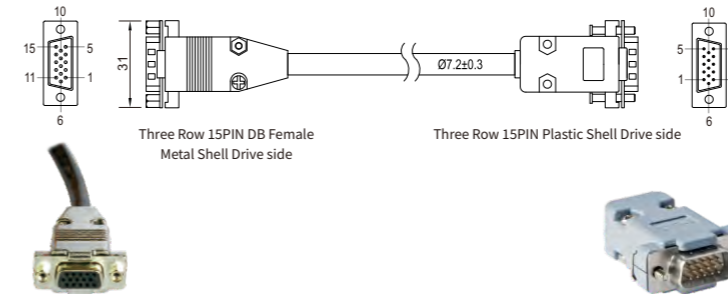

ENCOA-LL-KH

Wire spec: 24AWG/1P+28AWG/7P+AB 1061
24AWG cross sectional area 0.2047mm²
28AWG cross sectional area 0.0804mm²

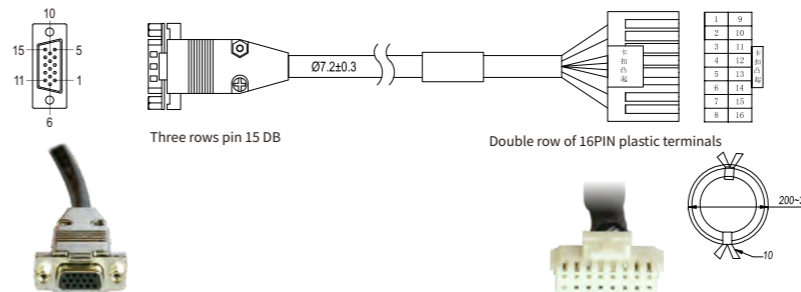

ENCHA-LL-KC0

Wire spec: 24AWG/1P+28AWG/7P+AB 1061
24AWG cross sectional area 0.2047mm²
28AWG cross sectional area 0.0804mm²

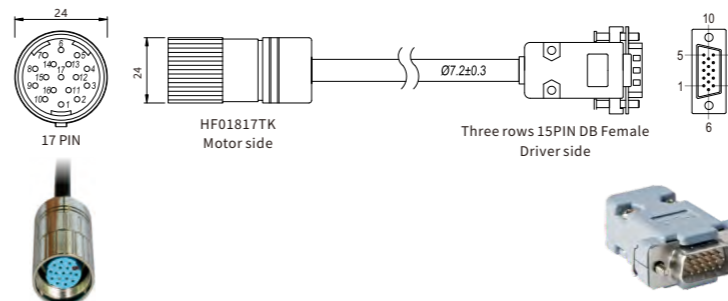

ENCHA-LL-KH			
Three rows of 15PIN DB Female	Three rows of 15PIN DB Male	Signal	Color
PIN1	PIN1	+5V	Red (Thick)
PIN8	PIN8	A	Orange
PIN7	PIN7	B	Yellow
PIN6	PIN6	Z	Green
PIN4	PIN4	U	Brown
PIN10	PIN10	V	Purple
PIN9	PIN9	W	Blue
PIN2	PIN2	GND	Black (Thick)
PIN13	PIN13	/A	Orange white
PIN12	PIN12	/B	Yellow white
PIN11	PIN11	/Z	Green white
PIN5	PIN5	/U	Brown white
PIN15	PIN15	/V	Purple white
PIN14	PIN14	/W	Blue white
Shell	Shell	Shielded	Shielded wire

Corresponding accessory: ENCHA-KH

corresponding flexible cable **ENCHAF-LL-KH**
Wire specification: 2*24AWG+7*2*26AWG BLACK
Wire diameter: 10 ± 0.5mm

ENCOA-LL-KH			
Three rows pin 15 DB	Double row of 16PIN plastic terminals	Signal	Color
PIN1	PIN15	+5V	Red (Thick)
PIN8	PIN13	A	Orange
PIN7	PIN11	B	Yellow
PIN6	PIN9	Z	Green
PIN4	PIN7	U	Brown
PIN10	PIN5	V	Purple
PIN9	PIN4	W	Blue
PIN2	PIN16	GND	Black (Thick)
PIN13	PIN14	/A	Orange white
PIN12	PIN12	/B	Yellow white
PIN11	PIN10	/Z	Green white
PIN5	PIN8	/U	Brown white
PIN15	PIN6	/V	Purple white
PIN14	PIN4	/W	Blue white
Shell	PIN2	Shielding	Shielded wire

Corresponding accessory package: ENCOA-KH

Corresponding flexible cable **ENCOAF-LL-KH**
Wire specification: 2*24AWG+7*2*26AWG BLACK
Wire diameter: 10 ± 0.5mm

ENCHA-LL-KC0			
17 PIN Air insertion	Three rows pin 15 DB	Signal	Color
PIN1	PIN1	+5V	Red (Thick)
PIN3	PIN8	A	Orange
PIN5	PIN7	B	Yellow
PIN14	PIN6	Z	Green
PIN9	PIN4	U	Brown
PIN11	PIN10	V	Purple
PIN16	PIN9	W	Blue
PIN2	PIN2	GND	Black (Thick)
PIN4	PIN13	/A	Orange white
PIN6	PIN12	/B	Yellow white
PIN15	PIN11	/Z	Green white
PIN10	PIN5	/U	Brown white
PIN12	PIN15	/V	Purple white
PIN17	PIN14	/W	Blue white
Belonging ring	Belonging to the shell	Shielding	Shielded wire

Corresponding accessory package: ENCHA-KC0

Corresponding flexible cable **ENCHAF-LL-KC0**
Wire specification: 2*24AWG+7*2*26AWG BLACK
Wire diameter: 10 ± 0.5mm

Cable(encoder cable/brake cable)

BRA-LL-KL

Wire spec: 2C×20AWG
20AWG cross sectional area 0.5189mm²

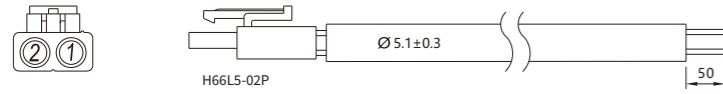

BRA-LL-KL

Color	Signal	2PIN terminal
Red	brake +	PIN1
Blue	brake -	PIN2

Corresponding accessory package: BRA-KL

Corresponding flexible cable **BRAF-LL-KL**
Wire specification: 2C*20AWG(72/0.10T) 5 million times
Wire diameter: 5.5±0.5mm

BRAF-(2)-M

Wire spec: 2x20AWG, drag chain 500 million times
20AWG cross sectional area 0.5189mm²

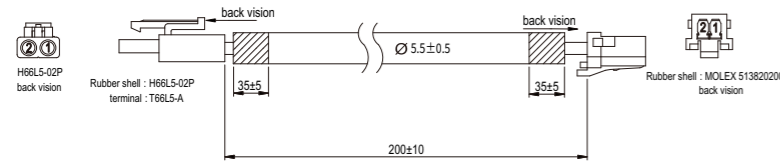

BRAF-(2)-M

H66L5-02P	Color	Signal	MOLEX 39012020
PIN1	red	break+	PIN1
PIN2	blue	break-	PIN2