

- **Frameless Torque Motors**
- Induction Motors
- PMDC Motors

# Frameless Direct Drive Torque Motors

NEW LAUNCH



## Key Applications



Gimbals



Robot Arms



Index Tables



Defence

# Compact, Fully-integrated Frameless torque motors

Widely used for applications like Gimbals, Robot arms, Index tables and many such high precision applications. Torque motors from Pranshu comes with Large through holes and low profile motors.

Frameless Torque Motors from Pranshu consist of a separate rotor and stator which are assembled directly

inside the machine. The result is a compact, fully-integrated motor with improved dynamic performance.

Frameless Torque Motor's winding can be customized to get any desired speed as per specific requirement of the application.

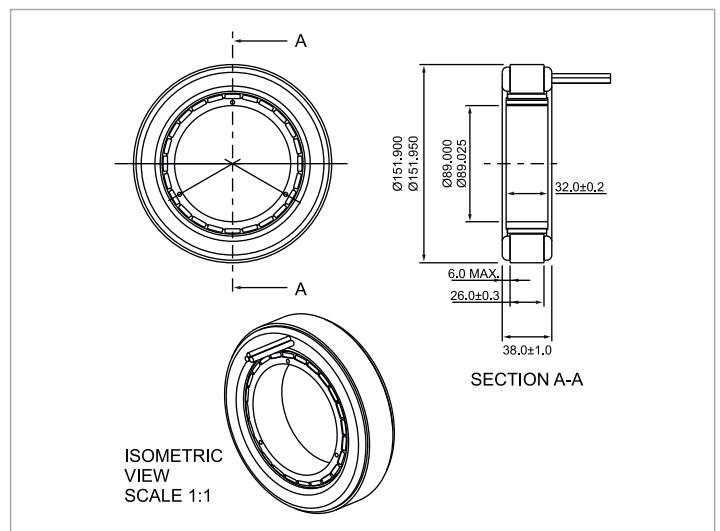

## Features

- Eliminates gearing issues by providing high torque at low speed
- Direct drive (No gear, no backlash)
- Low height with wider hollow shaft
- Easy to integrate in the system
- Assured higher accuracy
- Low noise

## Why us?

Beyond motors; what drives our engagement with the customers...



PERFORMANCE



PROVEN



PARTNER

28+ Years of Expertise

1000+ Happy Customers

5 Lac+ Motors Installed

# Product Details

Electrical Specification	Unit	T-I-065-18-07-N-AB	T-I-100-25-12-N-AB	T-I-100-60-40-N-AB	T-I-152-38-93-N-AB	T-I-230-35-130-N-AB	T-I-410-45-235-N-AB
Continuous Torque	Nm	0.25	1	4	8	16	70
Continuous Current	A	2.9	5	7	5.5	11	28
Phases		3	3	3	3	3	3
Kt (Torque Constant)	Nm /Amp	0.086	0.2	0.57	1.454	1.45	2.5
Ke (Voltage Constant)	V/Krpm	7	12	40	93	130	235
Km (Motor Constant)	Nm/ $\sqrt{W}$	0.075	0.26	0.75	1.26	1.96	7.21
Resistance	Ohm	1.322	0.58	0.576	1.33	0.548	0.12
Poles		8	12	12	24	48	64
Mechanical Specifications							
Stator OD	mm	65	100	100	152	230	410
Stator ID	mm	35	65	65	108	184.5	332
Rotor OD	mm	33.3	63	63	106.5	183	330
Rotor ID	mm	17	38	38	89	155	290
Air Gap	mm	0.85	1	1	0.75	0.75	1
Total Length	mm	18	25	60	38	35	45
Stator Core Length	mm	10	10	40	26	22	25
Weight	kg	0.25	0.6	1.8	1.9	3	12

## Model Numbering

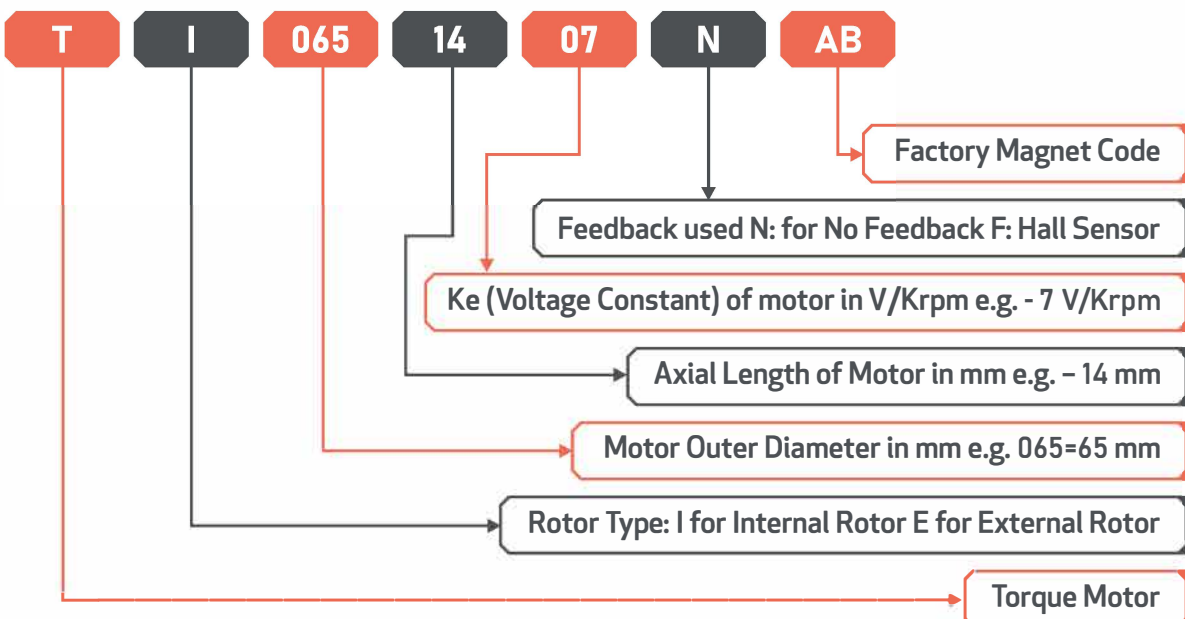

# Your premium partner for motion control

Since 1994 Motion Control Products Limited has been at the forefront of advanced motion control and automation with the supply of our extensive range of products. These include motors, drives, integrated motors with electronics, gearboxes, actuators, multi-axis controllers, collaborative robots and mechanical components to suit the widest range of Original Equipment Manufacturers (OEM's) application needs. MCP's electric and mechanical products are used in a variety of industries, including the packaging, material handling, medical, food processing, automotive, semiconductor and general automation industries.



## MOTION CONTROL PRODUCTS LTD.

📍 11-15 Francis Avenue, Bournemouth, Dorset, UK BH1 1 8NX

☎ +44 (0)1202 599922

✉ enquiries@motioncontrolproducts.com

🌐 www.motioncontrolproducts.com

