

AXD-ERA SERIES

- ▶ Absolute encoder (BiSS-C)
- ▶ Strong resistance to contamination
- ▶ Direct drive brushless motor
- ▶ Low cogging torque
- ▶ Optional for low speed and high speed windings
- ▶ High torque density

EN-24.6.1

UK & Ireland Official Distributor



11-15 Francis Avenue, Bournemouth,
Dorset UK BH11 8NX
Tel.: (+44) 01202 599922
enquiries@motioncontrolproducts.com
www.motioncontrolproducts.com

Introduction

The AXD-ERA series represents a type of iron core motor featuring an absolute encoder utilizing the BiSS-C protocol. One of its advantages over the AXD series is the absolute encoder, which provides accurate position information even in the event of power loss.

With a repeatability of ± 1.5 arcsec (where 1 arcsec equals 1/3600 degree), the motor delivers a high level of precision. Its accuracy can range from ± 15 arcsec (without error mapping) to ± 3 arcsec (with error mapping).

And besides, the resistance to contamination and reliability of motor is improved tremendously by innovative design. Despite slight pollution in certain environments, the motor is capable of operating normally.

This feature makes it suitable for a wide range of applications where ± 15 arcsec of absolute positioning accuracy can be achieved without error compensation.

Continuous Torque $T_{cn} = 3.4\text{Nm} \sim 250.6\text{Nm}$





Peak Torque $T_{pk} = 10\text{Nm} \sim 648.9\text{Nm}$

Features

- ▶ Absolute encoder (BiSS-C)
- ▶ Strong resistance to contamination
- ▶ Direct drive brushless motor
- ▶ Low cogging torque
- ▶ Optional for low speed and high speed windings
- ▶ High torque density

Applications

It is suitable for all kinds of industrial applications, even though in some slightly polluted environment that involves dust and oil. It is also suitable for application that requires absolute encoder with high repeatability and accuracy requirement without error mapping.

	Model	Diameter (mm)	Height (mm)	● Continuous Torque(T_{cn}) / ■ Peak Torque(T_{pk})						Unit: Nm
				10	50	100	200	300	400	
	AXD120-ERA	120	71	● 3.4 / ■ 10						
	AXD160-ERA	160	77	● 9.4 / ■ 27						
	AXD200-ERA	200	87	● 18.8 / ■ 54.3						
	AXD280-ERA	280	100	● 51.1 / ■ 150.3						
	AXD400-ERA	400	180				● 250.6 / ■ 648.9			

AXD120-71

AXD120-71				
Performance Parameters	Symbol	Unit	Series	Parallel
Continuous Torque (NC) @100°C ¹	T _{cn}	Nm	3.4	3.4
Peak Torque	T _{pk}	Nm	10.0	10.0
Torque Constant ±10%	K _t	Nm/Arms	3.0	1.5
Back EMF Constant ±10%	K _e	Vpeak/rpm	0.26	0.13
Motor Constant @25°C	K _m	Nm/Sqrt(W)	0.64	0.64
Resistance (L-L) @25°C ±10% ²	R ₂₅	Ω	15.2	3.8
Inductance (L-L) ±20% ³	L	mH	47.7	11.9
Electrical Time Constant	τ _e	ms	3.1	3.1
Continuous Current (NC) @100°C ¹	I _{cn}	Arms	1.1	2.2
Peak Current	I _{pk}	Arms	3.9	7.8
Continuous Power Dissipation (NC) @100°C ¹	P _n	W	36.4	36.4
Max. Coil Temperature	T _{max}	°C	100	100
Thermal Dissipation Constant (NC) ⁴	K _{thn}	W/°C	0.5	0.5
Max. Bus Voltage	U _{bus}	Vdc	600	600
Pole Number	2p	-	14	14
Max. Speed @Continuous Torque ⁵	Ω _{max}	rpm	1700	2000
Max. Speed @Peak Torque ⁶	Ω _{max}	rpm	1400	2000
Mechanical Parameters				
Overall Mass (NC)	m _n	kg	3.1	3.1
Rotor Inertia	J _r	kg·m ²	1.18E-03	1.18E-03
Axial Runout ⁷	-	μm	20(10)	20(10)
Radial Runout ⁸	-	μm	20(10)	20(10)
Max. Axial Load (Upright Mounting) ⁹	-	N	500	500
Max. Axial Load (Inverted / Wall Mounting)	-	N	150	150
Max. Moment Load (Upright Mounting)	-	Nm	30	30
Max. Moment Load (Inverted / Wall Mounting)	-	Nm	10	10
Encoder Parameters				
Absolute Encoder	-	bit	23	23
Communication Protocol	-	-	BiSS-C	BiSS-C
Accuracy after Error Mapping ¹⁰	-	arc sec	±4(±3)	±4(±3)
Accuracy without Error Mapping ¹¹	-	arc sec	±20(±15)	±20(±15)
Repeatability ¹²	-	arc sec	±2(±1.5)	±2(±1.5)
Other Information				
Insulation Class	Class B (130°C)			
Protection Grade	IP40			
Compliance with Global Standards	RoHS, CE			
Ambient Temperature	Operation	0°C to 40°C (non-freezing)		
	Storage	-15°C to 70°C (non-freezing)		
Ambient Humidity	Operation	10%RH to 80%RH (non-condensing)		
	Storage	10%RH to 90%RH (non-condensing)		
Recommended Ambience	Indoor (no direct sunlight); No corrosive gas, inflammable gas, oil mist or dust.			

- ¹ Measurement is taken at ambient temperature 25°C. Value depends on the thermal environment.
 - ² Resistance is measured by DC current with standard 0.5m cable.
 - ³ Inductance is measured by current frequency of 1 kHz.
 - ⁴ The value is based on absolute encoder under max. bus voltage.
 - ⁵ Runout specification define in the datasheet is based on constant loading and temperature condition (the value in parenthesis is optional).
 - ⁶ Please refer to the illustration for different mountings.
 - ⁷ The value outside the parenthesis is based on absolute encoder (S405) with the standard runout. The value in parenthesis is based on absolute encoder (S305) with the standard runout.
- The contents of datasheet are subject to change without prior notice.

Dimension

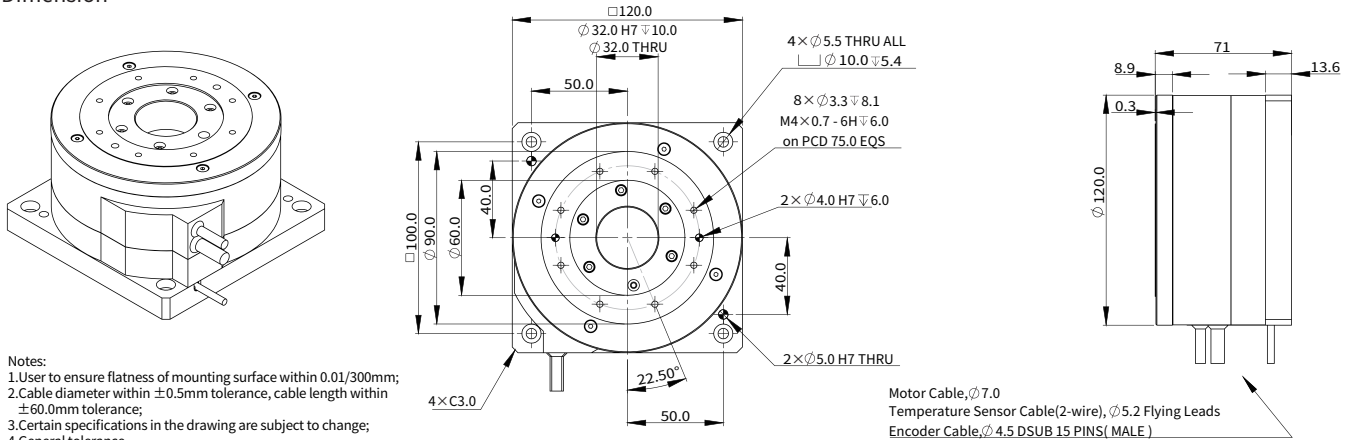

Torque-Speed Curve

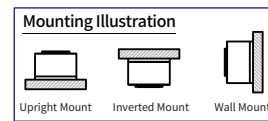
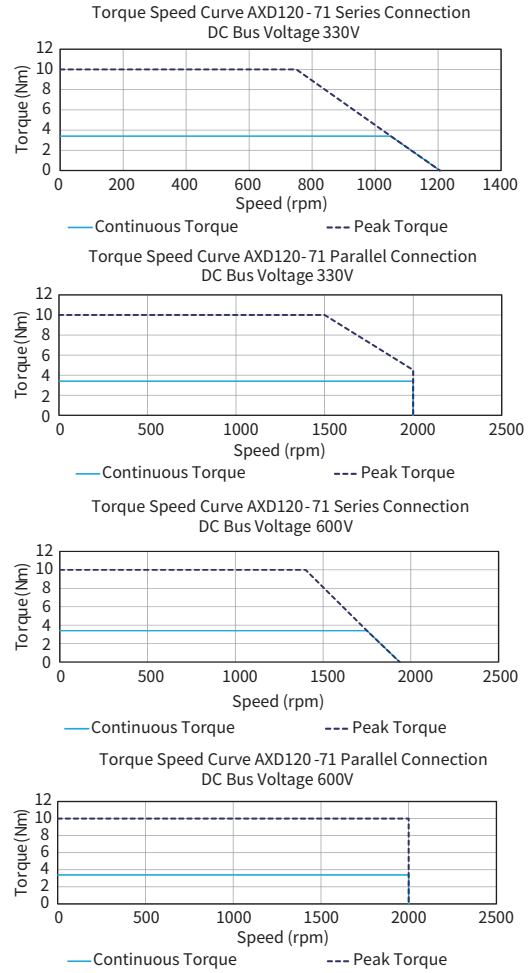

AXD160-77

AXD160-77				
Performance Parameters	Symbol	Unit	Series	Parallel
Continuous Torque (NC) @100°C ¹	T _{cn}	Nm	9.4	9.4
Peak Torque	T _{pk}	Nm	27.0	27.0
Torque Constant ±10%	K _t	Nm/Arms	5.8	2.9
Back EMF Constant ±10%	K _e	Vpeak/rpm	0.50	0.25
Motor Constant @25°C	K _m	Nm/Sqrt(W)	1.24	1.24
Resistance (L-L) @25°C ±10% ²	R ₂₅	Ω	14.9	3.7
Inductance (L-L) ±20% ³	L	mH	92.1	23.0
Electrical Time Constant	τ _e	ms	6.2	6.2
Continuous Current (NC) @100°C ¹	I _{cn}	Arms	1.6	3.2
Peak Current	I _{pk}	Arms	5.8	11.5
Continuous Power Dissipation (NC) @100°C ¹	P _{cn}	W	74.0	74.0
Max. Coil Temperature	T _{max}	°C	100	100
Thermal Dissipation Constant (NC) ³	K _{thn}	W/°C	1.0	1.0
Max. Bus Voltage	U _{bus}	Vdc	600	600
Pole Number	2p	-	14	14
Max. Speed @Continuous Torque ⁴	Ω _{max}	rpm	850	1000
Max. Speed @Peak Torque ⁴	Ω _{max}	rpm	550	1000
Mechanical Parameters				
Overall Mass (NC)	m _n	kg	6.1	6.1
Rotor Inertia	J _r	kg·m ²	4.15E-03	4.15E-03
Axial Runout ⁵	-	μm	30(10)	30(10)
Radial Runout ⁶	-	μm	30(10)	30(10)
Max. Axial Load (Upright Mounting) ⁶	-	N	750	750
Max. Axial Load (Inverted / Wall Mounting)	-	N	225	225
Max. Moment Load (Upright Mounting)	-	Nm	40	40
Max. Moment Load (Inverted / Wall Mounting)	-	Nm	12	12
Encoder Parameters				
Absolute Encoder	-	bit	23	23
Communication Protocol	-	-	BISS-C	BISS-C
Accuracy after Error Mapping ⁷	-	arc sec	±4(±3)	±4(±3)
Accuracy without Error Mapping ⁷	-	arc sec	±20(±15)	±20(±15)
Repeatability ⁷	-	arc sec	±2(±1.5)	±2(±1.5)
Other Information				
Insulation Class	Class B (130°C)			
Protection Grade	IP40			
Compliance with Global Standards	RoHS, CE			
Ambient Temperature	Operation	0°C to 40°C (non-freezing)		
	Storage	-15°C to 70°C (non-freezing)		
Ambient Humidity	Operation	10%RH to 80%RH (non-condensing)		
	Storage	10%RH to 90%RH (non-condensing)		
Recommended Ambience	Indoor (no direct sunlight); No corrosive gas, inflammable gas, oil mist or dust.			

- ¹ Measurement is taken at ambient temperature 25°C. Value depends on the thermal environment.
- ² Resistance is measured by DC current with standard 0.5m cable.
- ³ Inductance is measured by current frequency of 1 kHz.
- ⁴ The value is based on absolute encoder under max. bus voltage.
- ⁵ Runout specification define in the datasheet is based on constant loading and temperature condition (the value in parenthesis is optional).
- ⁶ Please refer to the illustration for different mountings.
- ⁷ The value outside the parenthesis is based on absolute encoder (S405) with the standard runout. The value in parenthesis is based on absolute encoder (S305) with the standard runout.

The contents of datasheet are subject to change without prior notice.

Dimension

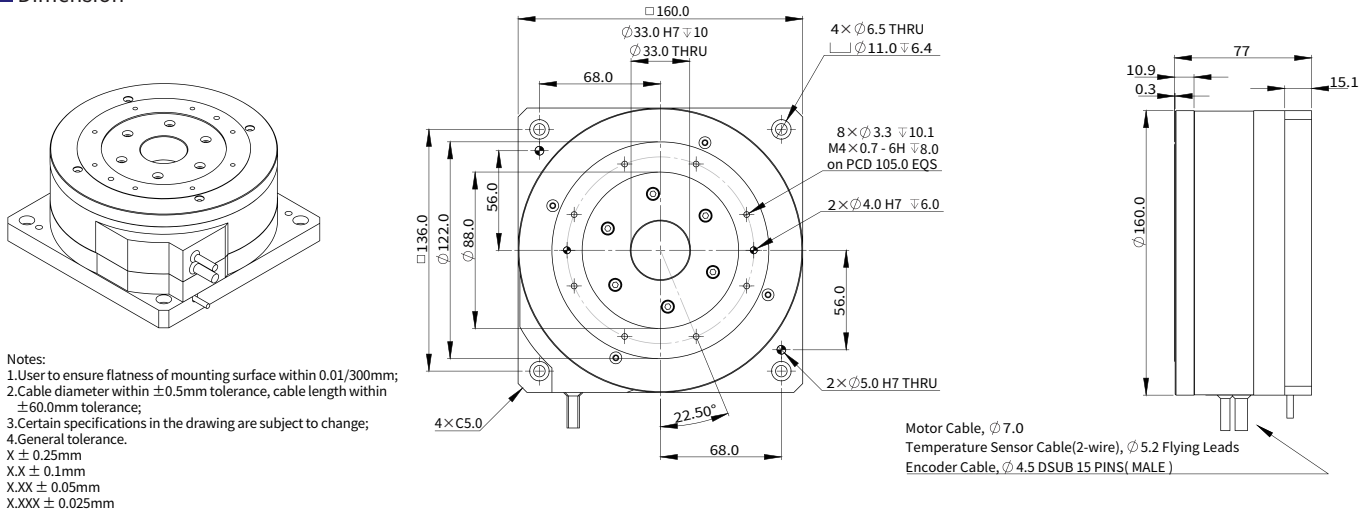

Torque-Speed Curve

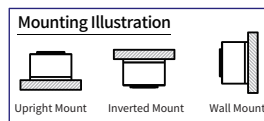
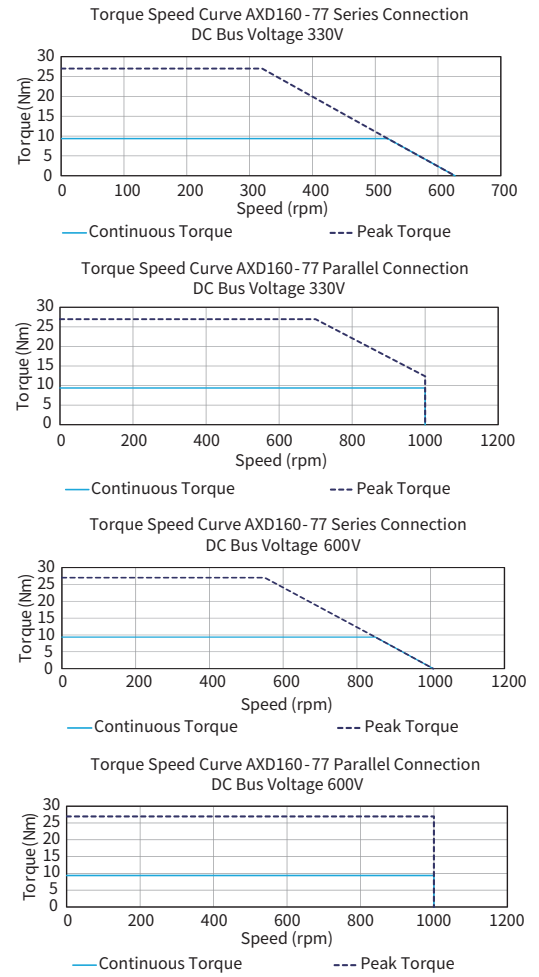

AXD200-87

AXD200-87				
Performance Parameters	Symbol	Unit	Series	Parallel
Continuous Torque (NC) @100°C ¹	T _{cn}	Nm	18.8	18.8
Peak Torque	T _{pk}	Nm	54.3	54.3
Torque Constant ±10%	K _t	Nm/Arms	9.4	4.7
Back EMF Constant ±10%	K _e	Vpeak/rpm	0.81	0.40
Motor Constant @25°C	K _m	Nm/Sqrt(W)	2.13	2.13
Resistance (L-L) @25°C ±10% ²	R ₂₅	Ω	13.0	3.3
Inductance (L-L) ±20% ³	L	mH	121.0	30.3
Electrical Time Constant	τ _e	ms	9.3	9.3
Continuous Current (NC) @100°C ¹	I _{cn}	Arms	2.0	4.0
Peak Current	I _{pk}	Arms	7.2	14.4
Continuous Power Dissipation (NC) @100°C ¹	P _{zn}	W	100.9	100.9
Max. Coil Temperature	T _{max}	°C	100	100
Thermal Dissipation Constant (NC) ⁴	K _{thn}	W/°C	1.3	1.3
Max. Bus Voltage	U _{bus}	Vdc	600	600
Pole Number	2p	-	14	14
Max. Speed @Continuous Torque ⁵	Ω _{max}	rpm	520	600
Max. Speed @Peak Torque ⁶	Ω _{max}	rpm	330	600
Mechanical Parameters				
Overall Mass (NC)	m _n	kg	9.5	9.5
Rotor Inertia	J _r	kg·m ²	1.14E-02	1.14E-02
Axial Runout ⁷	-	μm	40(10)	40(10)
Radial Runout ⁷	-	μm	40(10)	40(10)
Max. Axial Load (Upright Mounting) ⁷	-	N	1000	1000
Max. Axial Load (Inverted / Wall Mounting)	-	N	300	300
Max. Moment Load (Upright Mounting)	-	Nm	50	50
Max. Moment Load (Inverted / Wall Mounting)	-	Nm	15	15
Encoder Parameters				
Absolute Encoder	-	bit	23	23
Communication Protocol	-	-	BiSS-C	BiSS-C
Accuracy after Error Mapping ⁸	-	arc sec	±4(±3)	±4(±3)
Accuracy without Error Mapping ⁹	-	arc sec	±20(±15)	±20(±15)
Repeatability ¹⁰	-	arc sec	±2(±1.5)	±2(±1.5)
Other Information				
Insulation Class	Class B (130°C)			
Protection Grade	IP40			
Compliance with Global Standards	RoHS, CE			
Ambient Temperature	Operation	0°C to 40°C (non-freezing)		
	Storage	-15°C to 70°C (non-freezing)		
Ambient Humidity	Operation	10%RH to 80%RH (non-condensing)		
	Storage	10%RH to 90%RH (non-condensing)		
Recommended Ambience	Indoor (no direct sunlight); No corrosive gas, inflammable gas, oil mist or dust.			

- ¹ Measurement is taken at ambient temperature 25°C. Value depends on the thermal environment.
- ² Resistance is measured by DC current with standard 0.5m cable.
- ³ Inductance is measured by current frequency of 1 kHz.
- ⁴ The value is based on absolute encoder under max. bus voltage.
- ⁵ Runout specification define in the datasheet is based on constant loading and temperature condition (the value in parenthesis is optional).
- ⁶ Please refer to the illustration for different mountings.
- ⁷ The value outside the parenthesis is based on absolute encoder (S405) with the standard runout. The value in parenthesis is based on absolute encoder (S305) with the standard runout.

The contents of datasheet are subject to change without prior notice.

Dimension

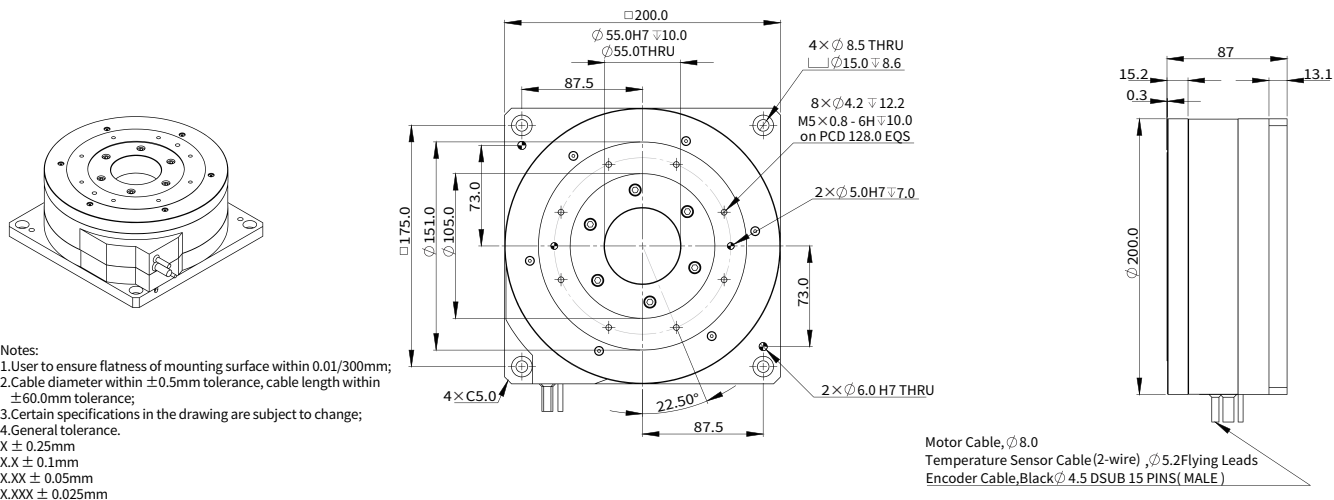

Torque-Speed Curve

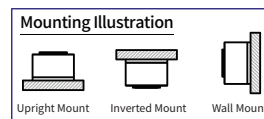
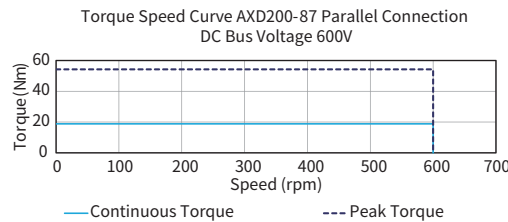
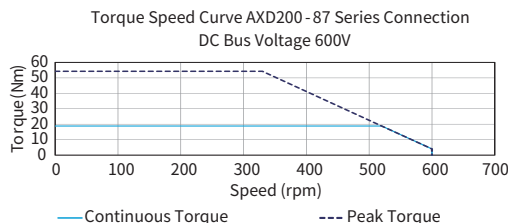
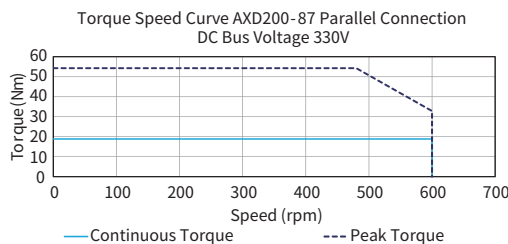
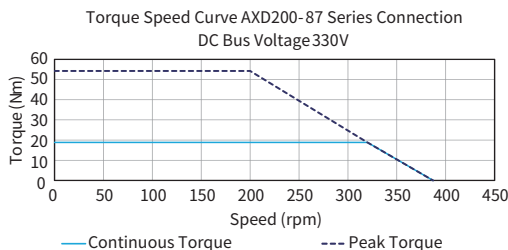

AXD400-180

AXD400-180				
Performance Parameters	Symbol	Unit	Series	Parallel
Continuous Torque (NC) @100°C ¹	T _{cn}	Nm	250.6	250.6
Peak Torque	T _{pk}	Nm	648.9	648.9
Torque Constant ±10%	K _t	Nm/Arms	35.8	17.9
Back EMF Constant ±10%	K _e	Vpeak/rpm	3.06	1.53
Motor Constant @25°C	K _m	Nm/Sqrt(W)	15.62	15.62
Resistance (L-L) @25°C ±10% ²	R ₂₅	Ω	3.5	0.9
Inductance (L-L) ±20% ³	L	mH	74.0	18.5
Electrical Time Constant	τ _e	ms	21.1	21.1
Continuous Current (NC) @100°C ⁴	I _{cn}	Arms	7.0	14.0
Peak Current	I _{pk}	Arms	25.0	50.0
Continuous Power Dissipation (NC) @100°C ⁴	P _{cn}	W	332.9	332.9
Max. Coil Temperature	T _{max}	°C	100	100
Thermal Dissipation Constant (NC) ⁵	K _{thn}	W/°C	4.4	4.4
Max. Bus Voltage	U _{bus}	Vdc	600	600
Pole Number	2p	-	28	28
Max. Speed @Continuous Torque ⁶	Ω _{max}	rpm	135	165
Max. Speed @Peak Torque ⁶	Ω _{max}	rpm	90	165
Mechanical Parameters				
Overall Mass (NC)	m _n	kg	100.0	100.0
Rotor Inertia	J _r	kg·m ²	5.15E-01	5.15E-01
Axial Runout ⁷	-	μm	70(20)	70(20)
Radial Runout ⁷	-	μm	70(20)	70(20)
Max. Axial Load (Upright Mounting) ⁸	-	N	8000	8000
Max. Axial Load (Inverted / Wall Mounting)	-	N	1500	1500
Max. Moment Load (Upright Mounting)	-	Nm	100	100
Max. Moment Load (Inverted / Wall Mounting)	-	Nm	30	30
Encoder Parameters				
Absolute Encoder	-	bit	23	23
Communication Protocol	-	-	BiSS-C	BiSS-C
Accuracy after Error Mapping ⁹	-	arc sec	±3	±3
Accuracy without Error Mapping ⁹	-	arc sec	±15	±15
Repeatability ⁹	-	arc sec	±1.5	±1.5
Other Information				
Insulation Class	Class B (130°C)			
Protection Grade	IP40			
Compliance with Global Standards	RoHS, CE			
Ambient Temperature	Operation	0°C to 40°C (non-freezing)		
	Storage	-15°C to 70°C (non-freezing)		
Ambient Humidity	Operation	10%RH to 80%RH (non-condensing)		
	Storage	10%RH to 90%RH (non-condensing)		
Recommended Ambience	Indoor (no direct sunlight); No corrosive gas, inflammable gas, oil mist or dust.			

- ¹ Measurement is taken at ambient temperature 25°C. Value depends on the thermal environment.
 - ² Resistance is measured by DC current with standard 0.5m cable.
 - ³ Inductance is measured by current frequency of 1 kHz.
 - ⁴ The value is based on absolute encoder under max. bus voltage.
 - ⁵ Runout specification define in the datasheet is based on constant loading and temperature condition (the value in parenthesis is optional).
 - ⁶ Please refer to the illustration for different mountings.
 - ⁷ Based on S305 absolute encoder with standard runout.
- The contents of datasheet are subject to change without prior notice.

Torque-Speed Curve

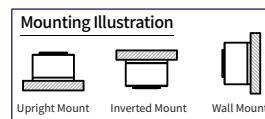
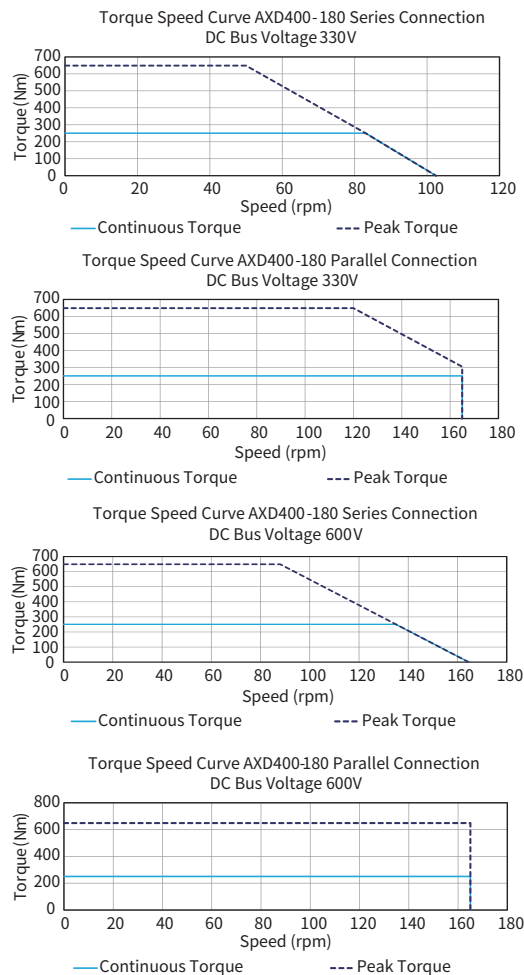

Dimension

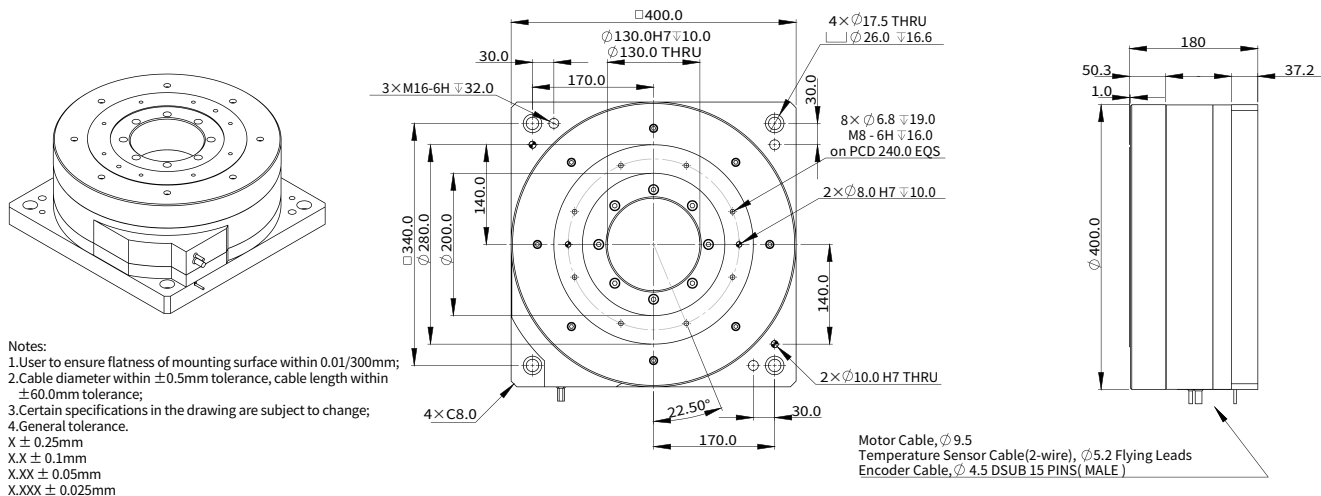

Motor Cable Connection

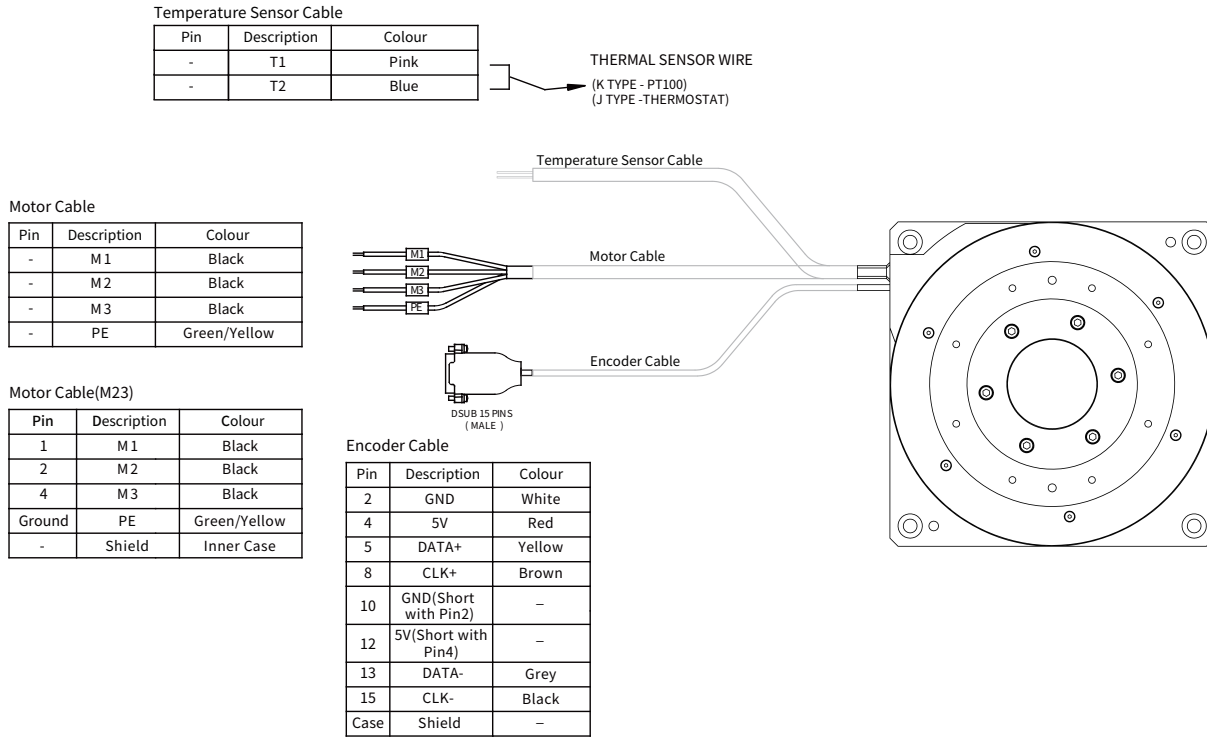

Motor Power Cable Information

Specification	Unit	
Cable Diameter	mm	"A" ¹
Cable Length	m	0.5 ¹
Number of Cores	-	"B"
Cable Colour	-	Grey
Minimum Bending Radius	mm	Moving:Cable diameter $\phi \times 12$ Fixed:Cable diameter $\phi \times 6$
Termination Type	-	Flying Leads
Ferrite Bead	-	Yes
CE Compliance	-	Yes

Encoder Cable Information

Specification	Unit	
Cable Diameter	mm	4.5 ¹
Cable Length	m	0.5 ¹
Number of Cores	-	6
Cable Colour	-	Black
Minimum Bending Radius	mm	Moving:Cable diameter $\phi \times 12$ Fixed:Cable diameter $\phi \times 6$

Temperature Sensor Cable Information

Specification	Unit	
Cable Diameter	mm	5.2 ¹
Cable Length	m	0.5 ¹
Number of Cores	-	2 \times 0.14mm ²
Cable Colour	-	Grey
Minimum Bending Radius	mm	Moving:Cable diameter $\phi \times 12$ Fixed:Cable diameter $\phi \times 6$
CE Compliance	-	Yes

Motor	AXD120	AXD160	AXD200	AXD280	AXD400
ϕ "A"	ϕ 7.0	ϕ 7.0	ϕ 8.0	ϕ 9.5	ϕ 9.5
"B"	4 \times 1.0mm ²	4 \times 1.0mm ²	4 \times 1.5mm ²	4 \times 2.5mm ²	4 \times 2.5mm ²

¹ Cable Diameter within ± 0.5 mm Tolerance, Cable Length within ± 60.0 mm Tolerance. Certain specifications in the drawing are subject to change.

Part Numbering

AXD160-77-P-J-NH-0.5-NFB-S305-P30

Motor Model:

AXD120-71 / AXD160-77
 AXD200-87 / AXD280-100
 AXD400-180

Runout:⁵

AXD120-71:P20 / P10
 AXD160-77:P30 / P10
 AXD200-87:P40 / P10
 AXD280-100:P50 / P15
 AXD400-180:P70 / P20

Winding Code:

S = Series / P = Parallel

Encoder:

S305 / S405

Thermal Sensor:

J = Thermostat / K = PT100 (RTD)

Power Cable:

NFB² / M23³

Sensor Cable:

NH¹

Cable Length(m):⁴

0.5

¹ NH = Without Built-in Hall Sensor C/W Flying Leads

² NFB = Without Ferrite Bead C/W Flying Leads

³ M23 = Without Ferrite Bead C/W M23 Receptacle

⁴ Cable Diameter within ±0.5mm Tolerance, Cable Length within ±60.0mm

⁵ AXD120-71:P20 = Axial Runout 20µm, Radial Runout is 20µm; P10 = Axial Runout 10µm, Radial Runout is 10µm
 AXD160-77:P30 = Axial Runout 30µm, Radial Runout is 30µm; P10 = Axial Runout 10µm, Radial Runout is 10µm
 AXD200-87:P40 = Axial Runout 40µm, Radial Runout is 40µm; P10 = Axial Runout 10µm, Radial Runout is 10µm
 AXD280-100:P50 = Axial Runout 50µm, Radial Runout is 50µm; P15 = Axial Runout 15µm, Radial Runout is 15µm
 AXD400-180:P70 = Axial Runout 70µm, Radial Runout is 70µm; P20 = Axial Runout 20µm, Radial Runout is 20µm

