

APEX DYNAMICS, INC.

**HIGH PRECISION
PLANETARY GEARBOX**

AB / ABR Series

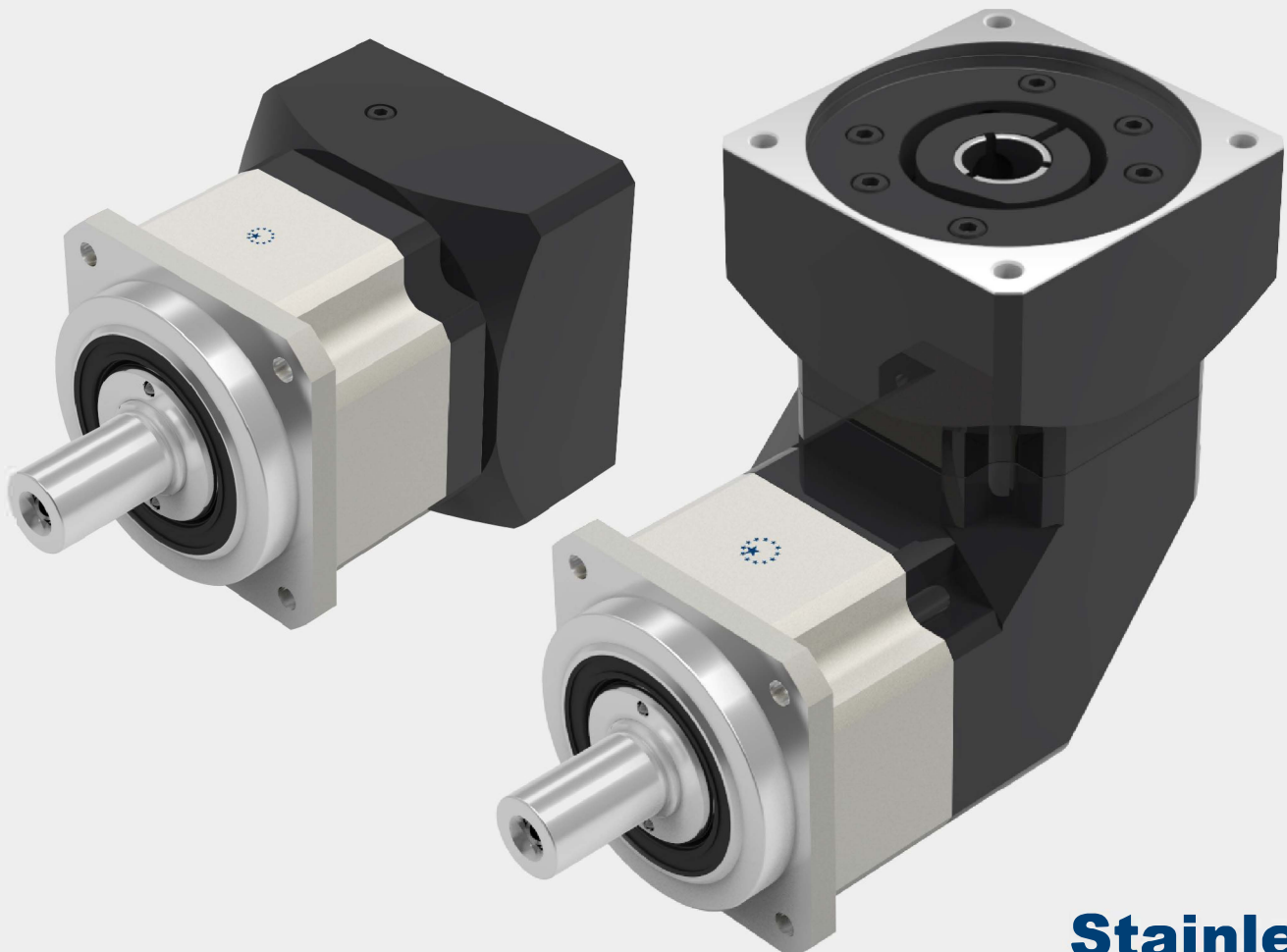

Stainless



Apex Dynamics, Inc. is the world's most productive manufacturer of servomotor drive planetary gearboxes for precision automation machinery. From our 800,000+ square foot ISO 9001:2008 manufacturing facility, based in Taichung, Taiwan, we manufacture to stock using the newest precision machine tools and quality test and inspection equipment. Complete focus on quality and precision allows us to produce our high quality gearheads at precision levels down to less than 1 arc minute (1/60 th of a degree), with consistency and high reliability.

Based on more than twenty years of accumulated manufacturing and marketing experience, plus the highest level of technical production capabilities, Apex Dynamics, Inc. designs and builds technically advanced, high speed, low backlash servo application planetary gearboxes. Our Break through patented technology (over 6 patents), provides the customer with the optimum high precision helical reducer at a reasonable price. We are continuously improving processes, finding proper and effective methods to provide customers new solutions for difficult applications, and developing new products.

The primary focus in daily operation is quality. We pride ourselves on our dedication to quality; our duty - is customer satisfaction.

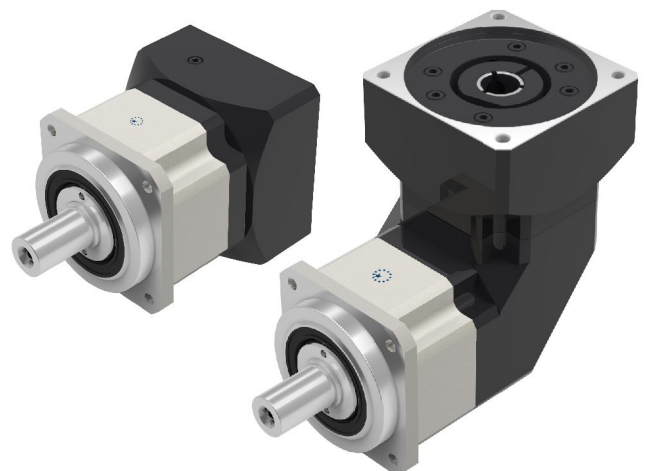

AB Series

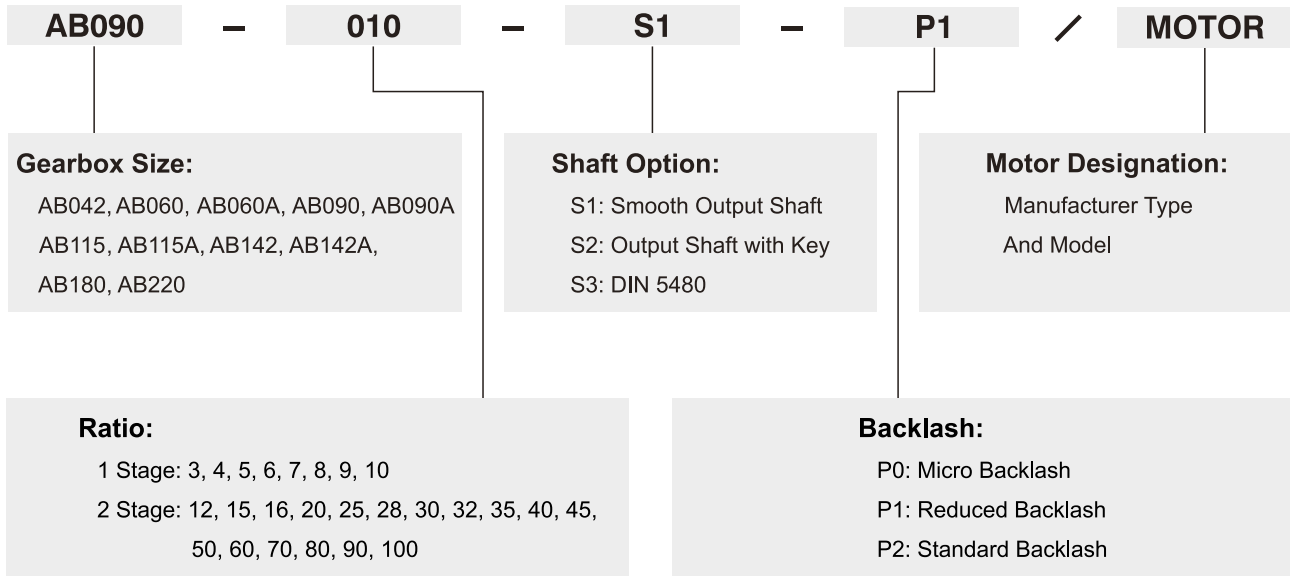

Ordering Example: AB090-010-S1-P1 / SIEMENS 1FT6 041-4AF71

ABR Series

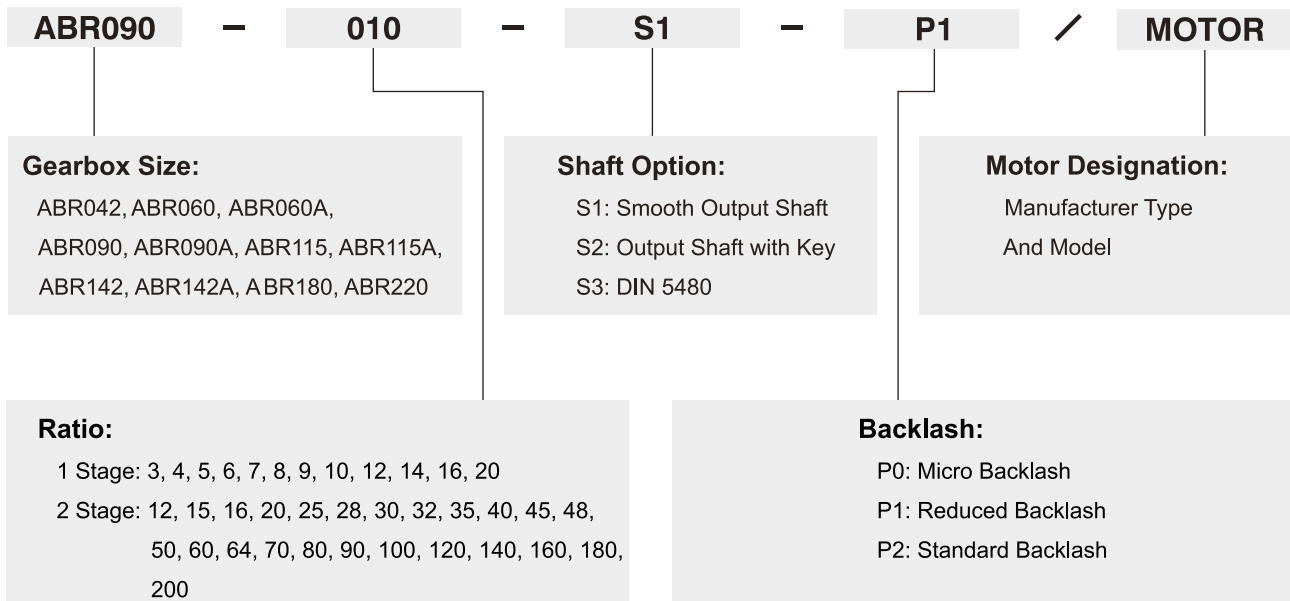

Ordering Example: ABR090-010-S1-P1 / SIEMENS 1FT6 041-4AF71



©2019 by APEX DYNAMICS, INC.
APEX DYNAMICS, INC. reserves modification and copyrights of all technical specifications, illustrations and drawings in this catalog in allowance for continuous products development and advancement.
For the newest data and information, please visit <http://www.apexdyna.com/>

Specifications / AB Series

Gearbox Performance

| Model No. | | Stage | Ratio ⁽¹⁾ | AB042 | AB060 | AB060A | AB090 | AB090A | AB115 | AB115A | AB142 | AB142A | AB180 | AB220 |
|--|-----------|-------|----------------------|----------------------------------|--------|--------|-------|--------|-------|--------|-------|--------|--------|--------|
| Nominal Output Torque T_{2N} | Nm | 1 | 3 | 20 | 55 | - | 130 | - | 208 | - | 342 | - | 588 | 1,140 |
| | | | 4 | 19 | 50 | - | 140 | - | 290 | - | 542 | - | 1,050 | 1,700 |
| | | | 5 | 22 | 60 | - | 160 | - | 330 | - | 650 | - | 1,200 | 2,000 |
| | | | 6 | 20 | 55 | - | 150 | - | 310 | - | 600 | - | 1,100 | 1,900 |
| | | | 7 | 19 | 50 | - | 140 | - | 300 | - | 550 | - | 1,100 | 1,800 |
| | | | 8 | 17 | 45 | - | 120 | - | 260 | - | 500 | - | 1,000 | 1,600 |
| | | | 9 | 14 | 40 | - | 100 | - | 230 | - | 450 | - | 900 | 1,500 |
| | | 10 | 14 | 40 | - | 100 | - | 230 | - | 450 | - | 900 | 1,500 | |
| | | 2 | 12 | 19 | 50 | 50 | 140 | 140 | 290 | 290 | 542 | 542 | 1,050 | 1,700 |
| | | | 15 | 20 | 55 | 55 | 130 | 130 | 208 | 208 | 342 | 342 | 588 | 1,140 |
| | | | 16 | 19 | 50 | 50 | 140 | 140 | 290 | 290 | 542 | 542 | 1,050 | 1,700 |
| | | | 20 | 19 | 50 | 50 | 140 | 140 | 290 | 290 | 542 | 542 | 1,050 | 1,700 |
| | | | 25 | 22 | 60 | 60 | 160 | 160 | 330 | 330 | 650 | 650 | 1,200 | 2,000 |
| | | | 28 | 19 | 50 | 50 | 140 | 140 | 300 | 300 | 550 | 550 | 1,100 | 1,800 |
| | | | 30 | 20 | 55 | 55 | 150 | 150 | 310 | 310 | 600 | 600 | 1,100 | 1,900 |
| | | | 32 | 17 | 45 | 45 | 120 | 120 | 260 | 260 | 500 | 500 | 1,000 | 1,600 |
| | | | 35 | 19 | 50 | 50 | 140 | 140 | 300 | 300 | 550 | 550 | 1,100 | 1,800 |
| | | | 40 | 17 | 45 | 45 | 120 | 120 | 260 | 260 | 500 | 500 | 1,000 | 1,600 |
| | | | 45 | 14 | 40 | 40 | 100 | 100 | 230 | 230 | 450 | 450 | 900 | 1,500 |
| | | | 50 | 22 | 60 | 60 | 160 | 160 | 330 | 330 | 650 | 650 | 1,200 | 2,000 |
| 60 | 20 | | 55 | 55 | 150 | 150 | 310 | 310 | 600 | 600 | 1,100 | 1,900 | | |
| 70 | 19 | 50 | 50 | 140 | 140 | 300 | 300 | 550 | 550 | 1,100 | 1,800 | | | |
| 80 | 17 | 45 | 45 | 120 | 120 | 260 | 260 | 500 | 500 | 1,000 | 1,600 | | | |
| 90 | 14 | 40 | 40 | 100 | 100 | 230 | 230 | 450 | 450 | 900 | 1,500 | | | |
| 100 | 14 | 40 | 40 | 100 | 100 | 230 | 230 | 450 | 450 | 900 | 1,500 | | | |
| Emergency Stop Torque $T_{2NOT}^{(2)}$ | Nm | 1,2 | 3~100 | 3 times of Nominal Output Torque | | | | | | | | | | |
| Nominal Input Speed n_{1N} | rpm | 1,2 | 3~100 | 5,000 | 5,000 | 5,000 | 4,000 | 4,000 | 4,000 | 4,000 | 3,000 | 3,000 | 3,000 | 2,000 |
| Max. Input Speed n_{1B} | rpm | 1,2 | 3~100 | 10,000 | 10,000 | 10,000 | 8,000 | 8,000 | 8,000 | 8,000 | 6,000 | 6,000 | 6,000 | 4,000 |
| Micro Backlash P0 | arcmin | 1 | 3~10 | - | - | - | ≤1 | - | ≤1 | - | ≤1 | - | ≤1 | ≤1 |
| | | 2 | 12~100 | - | - | - | - | - | ≤3 | ≤3 | ≤3 | ≤3 | ≤3 | ≤3 |
| Reduced Backlash P1 | arcmin | 1 | 3~10 | ≤3 | ≤3 | - | ≤3 | - | ≤3 | - | ≤3 | - | ≤3 | ≤3 |
| | | 2 | 12~100 | ≤5 | ≤5 | ≤5 | ≤5 | ≤5 | ≤5 | ≤5 | ≤5 | ≤5 | ≤5 | ≤5 |
| Standard Backlash P2 | arcmin | 1 | 3~10 | ≤5 | ≤5 | - | ≤5 | - | ≤5 | - | ≤5 | - | ≤5 | ≤5 |
| | | 2 | 12~100 | ≤7 | ≤7 | ≤7 | ≤7 | ≤7 | ≤7 | ≤7 | ≤7 | ≤7 | ≤7 | ≤7 |
| Torsional Rigidity | Nm/arcmin | 1,2 | 3~100 | 3 | 7 | 7 | 14 | 14 | 25 | 25 | 50 | 50 | 145 | 225 |
| Max. Radial Load $F_{2RB}^{(3)}$ | N | 1,2 | 3~100 | 780 | 1,530 | 1,530 | 3,250 | 3,250 | 6,700 | 6,700 | 9,400 | 9,400 | 14,500 | 50,000 |
| Max. Axial Load $F_{2AB}^{(3)}$ | N | 1,2 | 3~100 | 390 | 765 | 765 | 1,625 | 1,625 | 3,350 | 3,350 | 4,700 | 4,700 | 7,250 | 25,000 |
| Max. Tilting Moment M_{2K} | Nm | 1,2 | 3~100 | 25 | 70 | 70 | 200 | 200 | 550 | 550 | 990 | 990 | 1,760 | 7,630 |
| Efficiency η | % | 1 | 3~10 | ≥97% | | | | | | | | | | |
| | | 2 | 12~100 | ≥94% | | | | | | | | | | |
| Weight | kg | 1 | 3~10 | 0.6 | 1.3 | - | 3.7 | - | 7.8 | - | 13 | - | 26 | 45 |
| | | 2 | 12~100 | 0.8 | 1.5 | 1.9 | 4.1 | 5.3 | 9 | 11.4 | 17.5 | 20.7 | 32 | 57 |
| Operating Temp | °C | 1,2 | 3~100 | -10°C~90°C | | | | | | | | | | |
| Lubrication | | 1,2 | 3~100 | Synthetic lubrication oils | | | | | | | | | | |
| Degree of Gearbox Protection | | 1,2 | 3~100 | IP65 | | | | | | | | | | |
| Mounting Position | | 1,2 | 3~100 | all directions | | | | | | | | | | |
| Noise ⁽⁴⁾ | dB(A) | 1,2 | 3~100 | ≤56 | ≤58 | ≤60 | ≤60 | ≤63 | ≤63 | ≤65 | ≤65 | ≤67 | ≤67 | ≤70 |

(1) Ratio ($i=N_{in}/N_{out}$)

(2) Max. acceleration torque $T_{2B} = 60\%$ of T_{2NOT}

(3) Applied to the output shaft center at 100 rpm

(4) The dB values are measured by gearbox with ratio 10 (1-stage) or ratio 100 (2-stage), no loading at 3,000 RPM or at the respective Nominal Input Speed by bigger model size.
By lower ratio and/or higher RPM, the noise level could be 3 to 5 dB higher.

Max. Tilting Moment M_{2K}

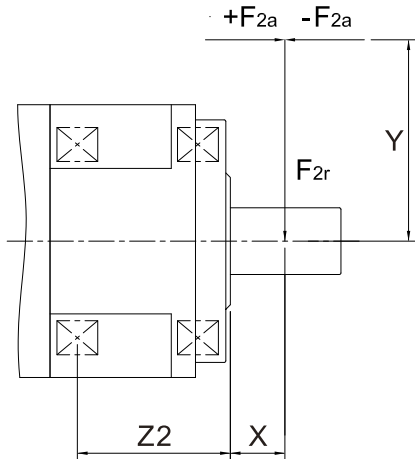

$$M_{2K} = \frac{F_{2a} * Y + F_{2r} * (X+Z2)}{1000}$$

M_{2K} : [Nm]
 F_{2a}, F_{2r} : [N]
 $X, Y, Z2$: [mm]

| AB / ABR | 042 | 060 | 090 | 115 | 142 | 180 | 220 |
|----------|-----|-----|------|------|------|-------|-------|
| Z2 [mm] | 31 | 42 | 56.5 | 71.5 | 85.5 | 102.5 | 127.1 |

Note : Applied to the output shaft center at 100 rpm.

Gearbox Inertia

| Model No. | Stage | Ratio ^A | AB042 | AB060 | AB060A | AB090 | AB090A | AB115 | AB115A | AB142 | AB142A | AB180 | AB220 | |
|-------------------------------|-------|--------------------|-------|-------|--------|-------|--------|-------|--------|-------|--------|-------|-------|-------|
| Mass Moments of Inertia J_1 | 1 | 3 | 0.03 | 0.16 | - | 0.61 | - | 3.25 | - | 9.21 | - | 28.98 | 69.61 | |
| | | 4 | 0.03 | 0.14 | - | 0.48 | - | 2.74 | - | 7.54 | - | 23.67 | 54.37 | |
| | | 5 | 0.03 | 0.13 | - | 0.47 | - | 2.71 | - | 7.42 | - | 23.29 | 53.27 | |
| | | 6 | 0.03 | 0.13 | - | 0.45 | - | 2.65 | - | 7.25 | - | 22.75 | 51.72 | |
| | | 7 | 0.03 | 0.13 | - | 0.45 | - | 2.62 | - | 7.14 | - | 22.48 | 50.97 | |
| | | 8 | 0.03 | 0.13 | - | 0.44 | - | 2.58 | - | 7.07 | - | 22.59 | 50.84 | |
| | | 9 | 0.03 | 0.13 | - | 0.44 | - | 2.57 | - | 7.04 | - | 22.53 | 50.63 | |
| | | 10 | 0.03 | 0.13 | - | 0.44 | - | 2.57 | - | 7.03 | - | 22.51 | 50.56 | |
| | | 12 | 0.03 | 0.03 | 0.16 | 0.16 | 0.61 | 0.61 | 3.25 | 3.25 | 9.21 | 9.21 | 28.98 | 69.61 |
| | | 15 | 0.03 | 0.03 | 0.13 | 0.13 | 0.47 | 0.47 | 2.71 | 2.71 | 7.42 | 7.42 | 23.29 | 53.27 |
| | 2 | 16 | 0.03 | 0.03 | 0.14 | 0.14 | 0.48 | 0.48 | 2.74 | 2.74 | 7.54 | 7.54 | 23.67 | 54.37 |
| | | 20 | 0.03 | 0.03 | 0.13 | 0.13 | 0.47 | 0.47 | 2.71 | 2.71 | 7.42 | 7.42 | 23.29 | 53.27 |
| | | 25 | 0.03 | 0.03 | 0.13 | 0.13 | 0.47 | 0.47 | 2.71 | 2.71 | 7.42 | 7.42 | 23.29 | 53.27 |
| | | 28 | 0.03 | 0.03 | 0.14 | 0.14 | 0.48 | 0.48 | 2.74 | 2.74 | 7.54 | 7.54 | 23.67 | 54.37 |
| | | 30 | 0.03 | 0.03 | 0.13 | 0.13 | 0.47 | 0.47 | 2.71 | 2.71 | 7.42 | 7.42 | 23.29 | 53.27 |
| | | 32 | 0.03 | 0.03 | 0.14 | 0.14 | 0.48 | 0.48 | 2.74 | 2.74 | 7.54 | 7.54 | 23.67 | 54.37 |
| | | 35 | 0.03 | 0.03 | 0.13 | 0.13 | 0.47 | 0.47 | 2.71 | 2.71 | 7.42 | 7.42 | 23.29 | 53.27 |
| | | 40 | 0.03 | 0.03 | 0.13 | 0.13 | 0.47 | 0.47 | 2.71 | 2.71 | 7.42 | 7.42 | 23.29 | 53.27 |
| | | 45 | 0.03 | 0.03 | 0.13 | 0.13 | 0.47 | 0.47 | 2.71 | 2.71 | 7.42 | 7.42 | 23.29 | 53.27 |
| | | 50 | 0.03 | 0.03 | 0.13 | 0.13 | 0.44 | 0.44 | 2.57 | 2.57 | 7.03 | 7.03 | 22.51 | 50.56 |
| 60 | 0.03 | 0.03 | 0.13 | 0.13 | 0.44 | 0.44 | 2.57 | 2.57 | 7.03 | 7.03 | 22.51 | 50.56 | | |
| 70 | 0.03 | 0.03 | 0.13 | 0.13 | 0.44 | 0.44 | 2.57 | 2.57 | 7.03 | 7.03 | 22.51 | 50.56 | | |
| 80 | 0.03 | 0.03 | 0.13 | 0.13 | 0.44 | 0.44 | 2.57 | 2.57 | 7.03 | 7.03 | 22.51 | 50.56 | | |
| 90 | 0.03 | 0.03 | 0.13 | 0.13 | 0.44 | 0.44 | 2.57 | 2.57 | 7.03 | 7.03 | 22.51 | 50.56 | | |
| 100 | 0.03 | 0.03 | 0.13 | 0.13 | 0.44 | 0.44 | 2.57 | 2.57 | 7.03 | 7.03 | 22.51 | 50.56 | | |

Dimensions (1-stage, Ratio i=3~10) / AB Series

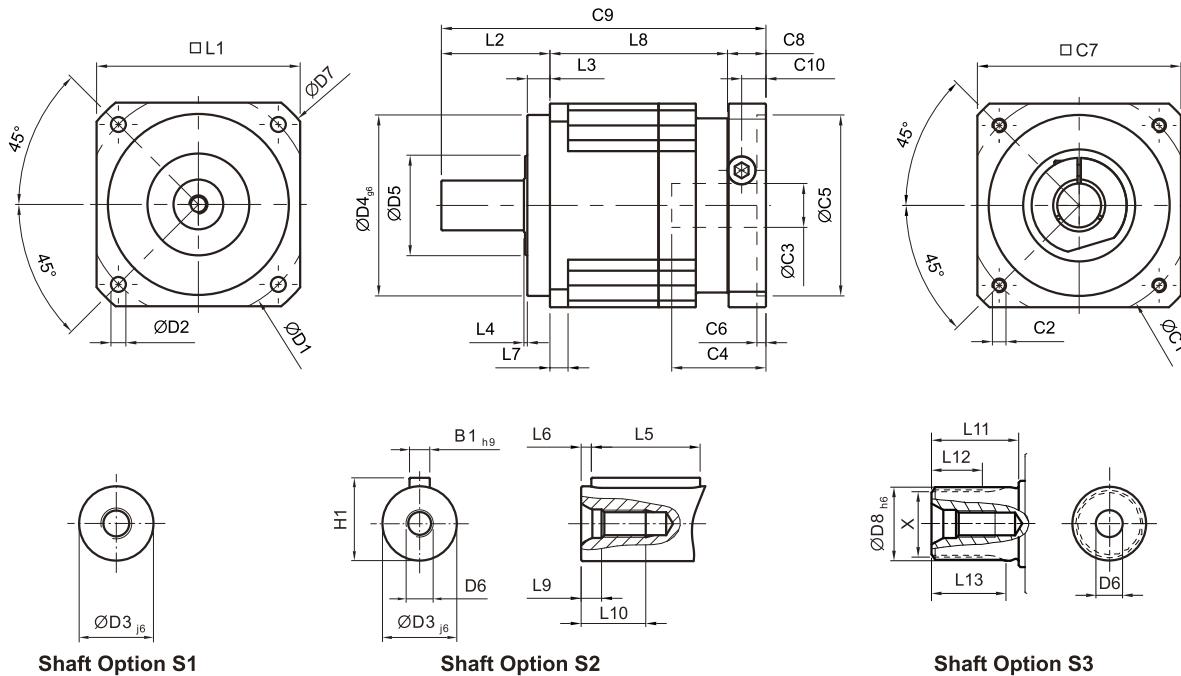

[unit: mm]

| Dimension | AB042 | AB060 | AB090 | AB115 | AB142 | AB180 | AB220 |
|------------------|------------------------|------------------------|------------|-------------|------------|-------------|-------------|
| D1 | 50 | 70 | 100 | 130 | 165 | 215 | 250 |
| D2 | 3.4 | 5.5 | 6.6 | 9 | 11 | 13 | 17 |
| D3 _{j6} | 13 | 16 | 22 | 32 | 40 | 55 | 75 |
| D4 _{g6} | 35 | 50 | 80 | 110 | 130 | 160 | 180 |
| D5 | 22 | 45 | 65 | 95 | 75 | 95 | 115 |
| D6 | M4 x 0.7P | M5 x 0.8P | M8 x 1.25P | M12 x 1.75P | M16 x 2P | M20 x 2.5P | M20 x 2.5P |
| D7 | 56 | 80 | 116 | 152 | 185 | 240 | 292 |
| D8 _{h6} | - | 16 | 22 | 32 | 40 | 55 | 75 |
| L1 | 42 | 60 | 90 | 115 | 142 | 180 | 220 |
| L2 | 26 | 37 | 48 | 65 | 97 | 105 | 138 |
| L3 | 5.5 | 7 | 10 | 12 | 15 | 20 | 30 |
| L4 | 1 | 1.5 | 1.5 | 2 | 3 | 3 | 3 |
| L5 | 16 | 25 | 32 | 40 | 63 | 70 | 90 |
| L6 | 2 | 2 | 3 | 5 | 5 | 6 | 7 |
| L7 | 4 | 6 | 8 | 10 | 12 | 15 | 20 |
| L8 | 31 | 61 | 78.5 | 102 | 119.5 | 154 | 163.5 |
| L9 | 4.5 | 4.8 | 7.2 | 10 | 12 | 15 | 15 |
| L10 | 10 | 12.5 | 19 | 28 | 36 | 42 | 42 |
| L11 | - | 26 | 26 | 26 | 40 | 41.5 | 52 |
| L12 | - | 15 | 15 | 15 | 20 | 21.5 | 28 |
| L13 | - | 21 | 22.5 | 23 | 33.5 | 33.5 | 45 |
| C1 ¹ | 46 | 70 | 100 | 130 | 165 | 215 | 235 |
| C2 ¹ | M4 x 0.7P | M5 x 0.8P | M6 x 1P | M8 x 1.25P | M10 x 1.5P | M12 x 1.75P | M12 x 1.75P |
| C3 ¹ | ≤11 / ≤12 ² | ≤14 / ≤16 ² | ≤19 / ≤24 | ≤32 | ≤38 | ≤48 | ≤55 |
| C4 ¹ | 25 | 34 | 40 | 50 | 60 | 85 | 116 |
| C5 ¹ | 30 | 50 | 80 | 110 | 130 | 180 | 200 |
| C6 ¹ | 3.5 | 8 | 4 | 5 | 6 | 6 | 6 |
| C7 ¹ | 42 | 60 | 90 | 115 | 142 | 190 | 220 |
| C8 ¹ | 29.5 | 19 | 17 | 19.5 | 22.5 | 29 | 63 |
| C9 ¹ | 86.5 | 117 | 143.5 | 186.5 | 239 | 288 | 364.5 |
| C10 ¹ | 8.75 | 13.5 | 10.75 | 13 | 15 | 20.75 | 53 |
| B1 _{h9} | 5 | 5 | 6 | 10 | 12 | 16 | 20 |
| | | | | | | | |

Dimensions (2-stage, Ratio i=12~100) / AB Series

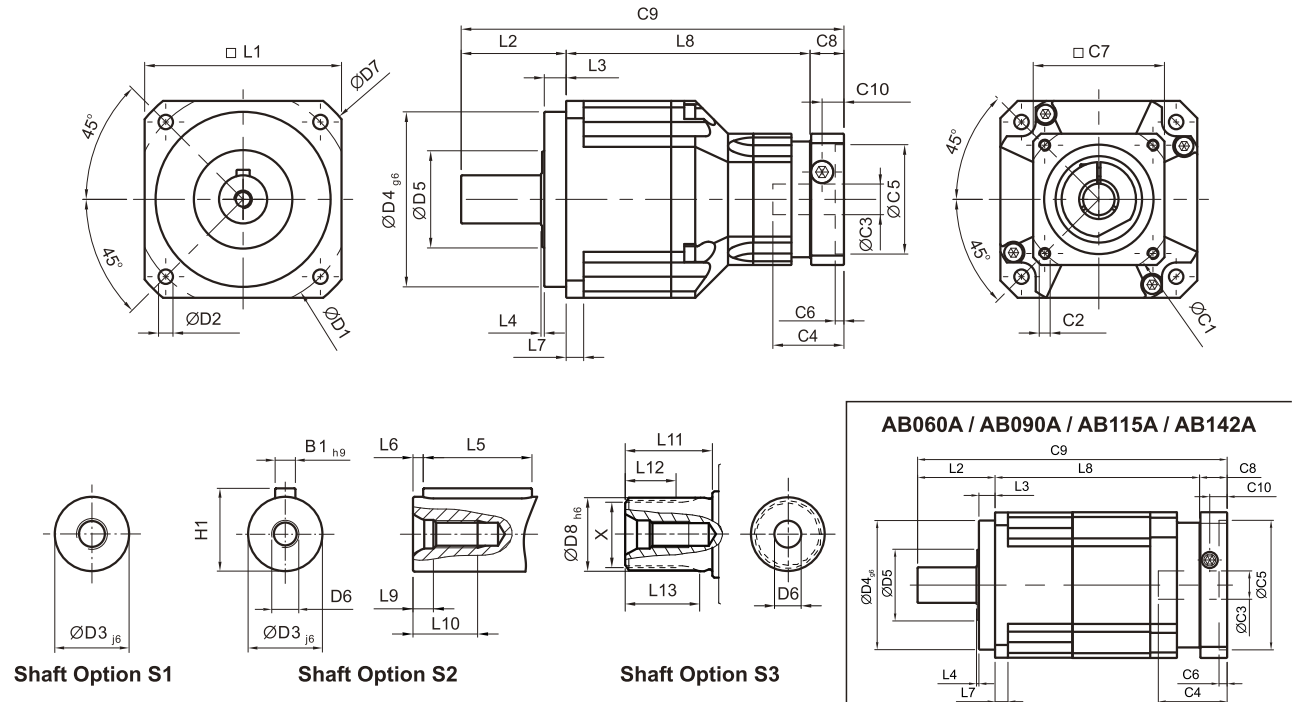

[unit: mm]

| Dimension | AB042 | AB060 | AB060A | AB090 | AB090A | AB115 | AB115A | AB142 | AB142A | AB180 | AB220 |
|------------------|-----------|----------------------|-----------|-----------------------|-----------|-----------------------|----------|--------------------|----------|--------------------|--------------------|
| D1 | 50 | 70 | | 100 | | 130 | | 165 | | 215 | 250 |
| D2 | 3.4 | 5.5 | | 6.6 | | 9 | | 11 | | 13 | 17 |
| D3 _{j6} | 13 | 16 | | 22 | | 32 | | 40 | | 55 | 75 |
| D4 _{g6} | 35 | 50 | | 80 | | 110 | | 130 | | 160 | 180 |
| D5 | 22 | 45 | | 65 | | 95 | | 75 | | 95 | 115 |
| D6 | M4x0.7P | M5 x 0.8P | | M8 x 1.25P | | M12x1.75P | | M16 x 2P | | M20x2.5P | M20x2.5P |
| D7 | 56 | 80 | | 116 | | 152 | | 185 | | 240 | 292 |
| D8 _{h6} | - | 16 | | 22 | | 32 | | 40 | | 55 | 75 |
| L1 | 42 | 60 | | 90 | | 115 | | 142 | | 180 | 220 |
| L2 | 26 | 37 | | 48 | | 65 | | 97 | | 105 | 138 |
| L3 | 5.5 | 7 | | 10 | | 12 | | 15 | | 20 | 30 |
| L4 | 1 | 1.5 | | 1.5 | | 2 | | 3 | | 3 | 3 |
| L5 | 16 | 25 | | 32 | | 40 | | 63 | | 70 | 90 |
| L6 | 2 | 2 | | 3 | | 5 | | 5 | | 6 | 7 |
| L7 | 4 | 6 | | 8 | | 10 | | 12 | | 15 | 20 |
| L8 | 58.5 | 72 | 98 | 111.5 | 126.5 | 143.5 | 163 | 176 | 191 | 209.5 | 248 |
| L9 | 4.5 | 4.8 | | 7.2 | | 10 | | 12 | | 15 | 15 |
| L10 | 10 | 12.5 | | 19 | | 28 | | 36 | | 42 | 42 |
| L11 | - | 26 | | 26 | | 26 | | 40 | | 41.5 | 52 |
| L12 | - | 15 | | 15 | | 15 | | 20 | | 21.5 | 28 |
| L13 | - | 21 | | 22.5 | | 23 | | 33.5 | | 33.5 | 45 |
| C1 ³ | 46 | 46 | 70 | 70 | 100 | 100 | 130 | 130 | 165 | 165 | 215 |
| C2 ³ | M4x0.7P | M4x0.7P | M5 x 0.8P | M5 x 0.8P | M6 x 1P | M6 x 1P | M8x1.25P | M8x1.25P | M10x1.5P | M10x1.5P | M12x1.75P |
| C3 ³ | ≤11 / ≤12 | ≤11 / ≤12 | ≤14 / ≤16 | ≤14 / ≤15.875 / ≤16 | ≤19 / ≤24 | ≤19 / ≤24 | ≤32 | ≤32 | ≤38 | ≤38 | ≤48 |
| C4 ³ | 25 | 25 | 34 | 34 | 40 | 40 | 50 | 50 | 60 | 60 | 85 |
| C5 ³ | 30 | 30 | 50 | 50 | 80 | 80 | 110 | 110 | 130 | 130 | 180 |
| C6 ³ | 3.5 | 3.5 | 8 | 8 | 4 | 4 | 5 | 5 | 6 | 6 | 6 |
| C7 ³ | 42 | 42 | 60 | 60 | 90 | 90 | 115 | 115 | 142 | 142 | 190 |
| C8 ³ | 29.5 | 29.5 | 19 | 19 | 17 | 17 | 19.5 | 19.5 | 22.5 | 22.5 | 29 |
| C9 ³ | 114 | 138.5 | 154 | 178.5 | 191.5 | 225.5 | 247.5 | 292.5 | 310.5 | 337 | 415 |
| C10 ³ | 8.75 | 8.75 | 13.5 | 13.5 | 10.75 | 10.75 | 13 | 13 | 15 | 15 | 20.75 |
| B1 _{h9} | 5 | 5 | | 6 | | 10 | | 12 | | 16 | 20 |
| H1 | 15 | 18 | | 24.5 | | 35 | | 43 | | 59 | 79.5 |
| X DIN5480 | - | W16x0.8x 30x18x6m | | W22x1.25x 30x16x6m | | W32x1.25x 30x24x6m | | W40x2x 30x18x6m | | W55x2x 30x26x6m | W70x2x 30x34x6m |

3. C1~C10 are motor specific dimensions (metric std shown). Refer to www.apexdyna.com and Design Tool to view your specific motor mounting system.

Specifications / ABR Series

Gearbox Performance

| Model No. | | Stage | Ratio ⁽¹⁾ | ABR042 | ABR060 | ABR060A | ABR090 | ABR090A | ABR115 | ABR115A | ABR142 | ABR142A | ABR180 | ABR220 | | |
|---|-----------|-------|----------------------|----------------------------------|--------|---------|--------|---------|--------|---------|--------|---------|--------|--------|---|---|
| Nominal Output Torque T_{2N} | Nm | 1 | 3 | 9 | 36 | - | 90 | - | 195 | - | 342 | - | 588 | 1,140 | | |
| | | | 4 | 12 | 48 | - | 120 | - | 260 | - | 520 | - | 1,040 | 1,680 | | |
| | | | 5 | 15 | 60 | - | 150 | - | 325 | - | 650 | - | 1,200 | 2,000 | | |
| | | | 6 | 18 | 55 | - | 150 | - | 310 | - | 600 | - | 1,100 | 1,900 | | |
| | | | 7 | 19 | 50 | - | 140 | - | 300 | - | 550 | - | 1,100 | 1,800 | | |
| | | | 8 | 17 | 45 | - | 120 | - | 260 | - | 500 | - | 1,000 | 1,600 | | |
| | | | 9 | 14 | 40 | - | 100 | - | 230 | - | 450 | - | 900 | 1,500 | | |
| | | | 10 | 14 | 60 | - | 150 | - | 325 | - | 650 | - | 1,200 | 2,000 | | |
| | | | 12 | - | 55 | - | 150 | - | 310 | - | 600 | - | 1,100 | 1,900 | | |
| | | | 14 | - | 42 | - | 140 | - | 300 | - | 550 | - | 1,100 | 1,800 | | |
| | | 16 | - | 45 | - | 120 | - | 260 | - | 500 | - | 1,000 | 1,600 | | | |
| | | 20 | - | 40 | - | 100 | - | 230 | - | 450 | - | 900 | 1,500 | | | |
| | | 2 | 12 | 12 | - | - | - | - | - | - | - | - | - | - | - | - |
| | | | 15 | 14 | - | - | - | - | - | - | - | - | - | - | - | - |
| | | | 16 | 15 | - | - | - | - | - | - | - | - | - | - | - | - |
| | | | 20 | 14 | - | - | - | - | - | - | - | - | - | - | - | - |
| | | | 25 | 15 | 60 | 60 | 150 | 150 | 325 | 325 | 650 | 650 | 1,200 | 2,000 | | |
| | | | 28 | 19 | 50 | 50 | 140 | 140 | 300 | 300 | 550 | 550 | 1,100 | 1,800 | | |
| | | | 30 | 20 | 55 | 55 | 150 | 150 | 310 | 310 | 600 | 600 | 1,100 | 1,900 | | |
| | | | 32 | 17 | 45 | 45 | 120 | 120 | 260 | 260 | 500 | 500 | 1,000 | 1,600 | | |
| | | | 35 | 19 | 50 | 50 | 140 | 140 | 300 | 300 | 550 | 550 | 1,100 | 1,800 | | |
| | | | 40 | 17 | 45 | 45 | 120 | 120 | 260 | 260 | 500 | 500 | 1,000 | 1,600 | | |
| | | | 45 | 14 | 40 | 40 | 100 | 100 | 230 | 230 | 450 | 450 | 900 | 1,500 | | |
| | | | 48 | - | - | 55 | 150 | 150 | 310 | 310 | 600 | 600 | 1,100 | 1,900 | | |
| | | | 50 | 14 | 60 | 60 | 150 | 150 | 325 | 325 | 650 | 650 | 1,200 | 2,000 | | |
| | | | 60 | 20 | 55 | 55 | 150 | 150 | 310 | 310 | 600 | 600 | 1,100 | 1,900 | | |
| | | | 64 | - | - | 45 | 120 | 120 | 260 | 260 | 500 | 500 | 1,000 | 1,600 | | |
| | | | 70 | 19 | 50 | 50 | 140 | 140 | 300 | 300 | 550 | 550 | 1,100 | 1,800 | | |
| | | | 80 | 17 | 45 | 45 | 120 | 120 | 260 | 260 | 500 | 500 | 1,000 | 1,600 | | |
| | | | 90 | 14 | 40 | 40 | 100 | 100 | 230 | 230 | 450 | 450 | 900 | 1,500 | | |
| | | | 100 | 14 | 40 | 60 | 150 | 150 | 325 | 325 | 650 | 650 | 1,200 | 2,000 | | |
| | | | 120 | - | - | 55 | 150 | 150 | 310 | 310 | 600 | 600 | 1,100 | 1,900 | | |
| 140 | - | - | 50 | 140 | 140 | 300 | 300 | 550 | 550 | 1,100 | 1,800 | | | | | |
| 160 | - | - | 45 | 120 | 120 | 260 | 260 | 500 | 500 | 1,000 | 1,600 | | | | | |
| 180 | - | - | 40 | 100 | 100 | 230 | 230 | 450 | 450 | 900 | 1,500 | | | | | |
| 200 | - | - | 40 | 100 | 100 | 230 | 230 | 450 | 450 | 900 | 1,500 | | | | | |
| Emergency Stop Torque T_{2NOT} ⁽²⁾ | Nm | 1,2 | 3~200 | 3 times of Nominal Output Torque | | | | | | | | | | | | |
| Nominal Input Speed n_{iN} | rpm | 1,2 | 3~200 | 5,000 | 5,000 | 5,000 | 4,000 | 4,000 | 4,000 | 4,000 | 3,000 | 3,000 | 3,000 | 2,000 | | |
| Max. Input Speed n_{iB} | rpm | 1,2 | 3~200 | 10,000 | 10,000 | 10,000 | 8,000 | 8,000 | 8,000 | 8,000 | 6,000 | 6,000 | 6,000 | 4,000 | | |
| Micro Backlash P0 | arcmin | 1 | 3~20 | - | - | - | ≤2 | - | ≤2 | - | ≤2 | - | ≤2 | ≤2 | | |
| | | 2 | 12~200 | - | - | - | ≤4 | ≤4 | ≤4 | ≤4 | ≤4 | ≤4 | ≤4 | ≤4 | | |
| Reduced Backlash P1 | arcmin | 1 | 3~20 | ≤4 | ≤4 | - | ≤4 | - | ≤4 | - | ≤4 | - | ≤4 | ≤4 | | |
| | | 2 | 12~200 | ≤7 | ≤7 | ≤7 | ≤7 | ≤7 | ≤7 | ≤7 | ≤7 | ≤7 | ≤7 | ≤7 | | |
| Standard Backlash P2 | arcmin | 1 | 3~20 | ≤6 | ≤6 | - | ≤6 | - | ≤6 | - | ≤6 | - | ≤6 | ≤6 | | |
| | | 2 | 12~200 | ≤9 | ≤9 | ≤9 | ≤9 | ≤9 | ≤9 | ≤9 | ≤9 | ≤9 | ≤9 | ≤9 | | |
| Torsional Rigidity | Nm/arcmin | 1,2 | 3~200 | 3 | 7 | 7 | 14 | 14 | 25 | 25 | 50 | 50 | 145 | 225 | | |
| Max. Radial Load F_{r2B} ⁽³⁾ | N | 1,2 | 3~200 | 780 | 1,530 | 1,530 | 3,250 | 3,250 | 6,700 | 6,700 | 9,400 | 9,400 | 14,500 | 50,000 | | |
| Max. Axial Load F_{a2B} ⁽³⁾ | N | 1,2 | 3~200 | 390 | 765 | 765 | 1,625 | 1,625 | 3,350 | 3,350 | 4,700 | 4,700 | 7,250 | 25,000 | | |
| Max. Tilting Moment M_{2K} | Nm | 1,2 | 3~200 | 25 | 70 | 70 | 200 | 200 | 550 | 550 | 990 | 990 | 1,760 | 7,630 | | |
| Efficiency η | % | 1 | 3~20 | ≥95% | | | | | | | | | | | | |
| | | 2 | 12~200 | ≥92% | | | | | | | | | | | | |
| Weight | kg | 1 | 3~20 | 0.9 | 2.1 | - | 6.4 | - | 12.1 | - | 23 | - | 44.5 | 77 | | |
| | | 2 | 12~200 | 1.2 | 1.8 | 2.7 | 4.8 | 7.9 | 11.5 | 15.9 | 21.5 | 29.6 | 41.5 | 75 | | |
| Operating Temp | °C | 1,2 | 3~200 | -10°C~+90°C | | | | | | | | | | | | |
| Lubrication | | 1,2 | 3~200 | Synthetic lubrication oils | | | | | | | | | | | | |
| Degree of Gearbox Protection | | 1,2 | 3~200 | IP65 | | | | | | | | | | | | |
| Mounting Position | | 1,2 | 3~200 | all directions | | | | | | | | | | | | |
| Noise ⁽⁴⁾ | dB(A) | 1,2 | 3~200 | ≤61 | ≤63 | ≤65 | ≤65 | ≤68 | ≤68 | ≤70 | ≤70 | ≤72 | ≤72 | ≤74 | | |

(1) Ratio ($i = N_{in} / N_{out}$)

(2) Max. acceleration torque $T_{2B} = 60\%$ of T_{2NOT}

(3) Applied to the output shaft center at 100 rpm

(4) The dB values are measured by gearbox with ratio 10 (1-stage) or ratio 100 (2-stage), no loading at 3,000 RPM or at the respective Nominal Input Speed by bigger model size.

By lower ratio and/or higher RPM, the noise level could be 3 to 5 dB higher.

Gearbox Inertia

| Model No. | | Stage | Ratio | ABR042 | ABR060 | ABR060A | ABR090 | ABR090A | ABR115 | ABR115A | ABR142 | ABR142A | ABR180 | ABR220 | |
|--|----------------------|-------|---------|--------|--------|---------|--------|---------|--------|---------|--------|---------|--------|--------|------|
| Mass Moments of Inertia J ₁ | kg · cm ² | 1 | 3~10 | 0.09 | 0.35 | – | 2.25 | – | 6.84 | – | 23.4 | – | 68.9 | 135.4 | |
| | | | 12~20 | – | 0.31 | – | 1.87 | – | 6.25 | – | 21.8 | – | 65.6 | 119.8 | |
| | | 2 | 12~20 | 0.09 | – | – | – | – | – | – | – | – | – | – | – |
| | | | 25~90 | 0.09 | 0.09 | 0.35 | 0.35 | 2.25 | 2.25 | 6.84 | 6.84 | 23.4 | 23.4 | 68.9 | 68.9 |
| | | | 48, 64 | – | – | 0.31 | 0.31 | 1.87 | 1.87 | 6.25 | 6.25 | 21.8 | 21.8 | 65.6 | 65.6 |
| | | | 100~200 | – | – | 0.31 | 0.31 | 1.87 | 1.87 | 6.25 | 6.25 | 21.8 | 21.8 | 65.6 | 65.6 |

Dimensions (1-stage, Ratio $i=3\sim 20$) / ABR Series

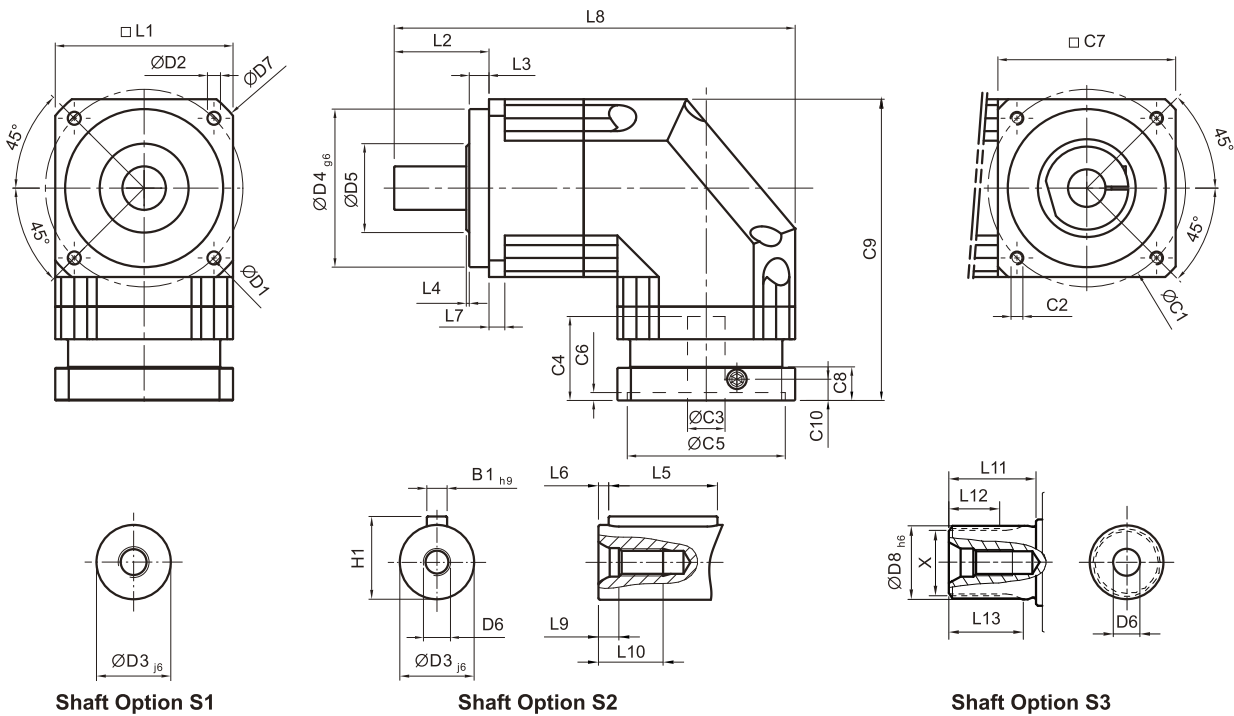

[unit: mm]

| Dimension | ABR042 | ABR060 | ABR090 | ABR115 | ABR142 | ABR180 | ABR220 |
|------------------|---------------------|----------------------|-----------------------|-----------------------|--------------------|--------------------|--------------------|
| D1 | 50 | 70 | 100 | 130 | 165 | 215 | 250 |
| D2 | 3.4 | 5.5 | 6.6 | 9 | 11 | 13 | 17 |
| D3 j6 | 13 | 16 | 22 | 32 | 40 | 55 | 75 |
| D4 g6 | 35 | 50 | 80 | 110 | 130 | 160 | 180 |
| D5 | 22 | 45 | 65 | 95 | 75 | 95 | 115 |
| D6 | M4 x 0.7P | M5 x 0.8P | M8 x 1.25P | M12 x 1.75P | M16 x 2P | M20 x 2.5P | M20 x 2.5P |
| D7 | 56 | 80 | 116 | 152 | 185 | 240 | 292 |
| D8 h6 | - | 16 | 22 | 32 | 40 | 55 | 75 |
| L1 | 42 | 60 | 90 | 115 | 142 | 180 | 220 |
| L2 | 26 | 37 | 48 | 65 | 97 | 105 | 138 |
| L3 | 5.5 | 7 | 10 | 12 | 15 | 20 | 30 |
| L4 | 1 | 1.5 | 1.5 | 2 | 3 | 3 | 3 |
| L5 | 16 | 25 | 32 | 40 | 63 | 70 | 90 |
| L6 | 2 | 2 | 3 | 5 | 5 | 6 | 7 |
| L7 | 4 | 6 | 8 | 10 | 12 | 15 | 20 |
| L8 | 111.5 | 145 | 203 | 259 | 333 | 394 | 484 |
| L9 | 4.5 | 4.8 | 7.2 | 10 | 12 | 15 | 15 |
| L10 | 10 | 12.5 | 19 | 28 | 36 | 42 | 42 |
| L11 | - | 26 | 26 | 26 | 40 | 41.5 | 52 |
| L12 | - | 15 | 15 | 15 | 20 | 21.5 | 28 |
| L13 | - | 21 | 22.5 | 23 | 33.5 | 33.5 | 45 |
| C1 ¹ | 46 | 70 | 100 | 130 | 165 | 215 | 235 |
| C2 ¹ | M4 x 0.7P | M5 x 0.8P | M6 x 1P | M8 x 1.25P | M10 x 1.5P | M12 x 1.75P | M12 x 1.75P |
| C3 ¹ | $\leq 11 / \leq 12$ | $\leq 14 / \leq 16$ | $\leq 19 / \leq 24$ | ≤ 32 | ≤ 38 | ≤ 48 | ≤ 55 |
| C4 ¹ | 25 | 34 | 40 | 50 | 60 | 85 | 116 |
| C5 ¹ | 30 | 50 | 80 | 110 | 130 | 180 | 200 |
| C6 ¹ | 3.5 | 8 | 4 | 5 | 6 | 6 | 6 |
| C7 ¹ | 42 | 60 | 90 | 115 | 142 | 190 | 220 |
| C8 ¹ | 29.5 | 19 | 17 | 19.5 | 22.5 | 29 | 63 |
| C9 ¹ | 90.5 | 111.5 | 152.5 | 191.5 | 235.5 | 303.5 | 378.5 |
| C10 ¹ | 8.75 | 13.5 | 10.75 | 13 | 15 | 20.75 | 53 |
| B1 h9 | 5 | 5 | 6 | 10 | 12 | 16 | 20 |
| H1 | 15 | 18 | 24.5 | 35 | 43 | 59 | 79.5 |
| X DIN5480 | - | W16x0.8x 30x18x6m | W22x1.25x 30x16x6m | W32x1.25x 30x24x6m | W40x2x 30x18x6m | W55x2x 30x26x6m | W70x2x 30x34x6m |

1. C1-C10 are motor specific dimensions (metric std shown). Refer to www.apexdyna.com and Design Tool to view your specific motor mounting system.

Dimensions (2-stage, Ratio i= 12~200) / ABR Series

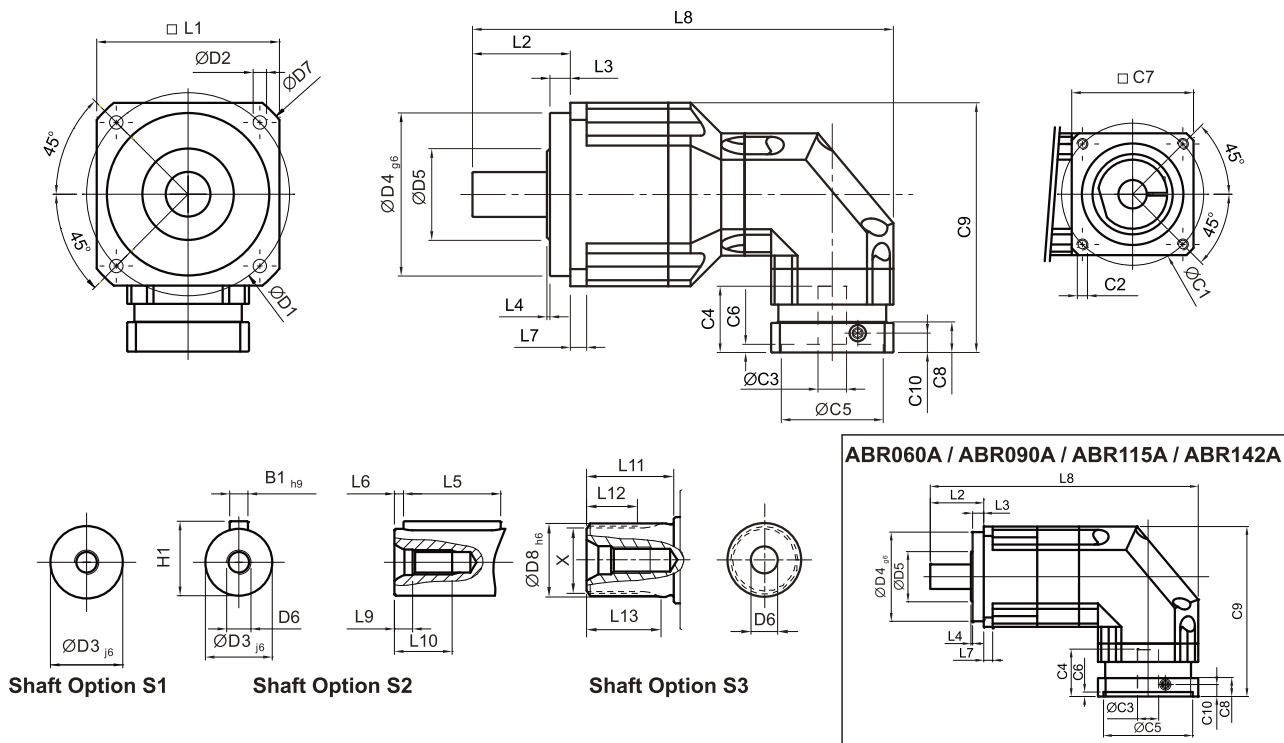

[unit: mm]

| Dimension | ABR042 | ABR060 | ABR060A | ABR090 | ABR090A | ABR115 | ABR115A | ABR142 | ABR142A | ABR180 | ABR220 |
|------------------|-----------|----------------------|-----------|-----------------------|-----------|-----------------------|------------|--------------------|------------|--------------------|--------------------|
| D1 | 50 | 70 | | 100 | | 130 | | 165 | | 215 | 250 |
| D2 | 3.4 | 5.5 | | 6.6 | | 9 | | 11 | | 13 | 17 |
| D3 _{js} | 13 | 16 | | 22 | | 32 | | 40 | | 55 | 75 |
| D4 _{g6} | 35 | 50 | | 80 | | 110 | | 130 | | 160 | 180 |
| D5 | 22 | 45 | | 65 | | 95 | | 75 | | 95 | 115 |
| D6 | M4 x 0.7P | M5 x 0.8P | | M8 x 1.25P | | M12 x 1.75P | | M16 x 2P | | M20 x 2.5P | M20 x 2.5P |
| D7 | 56 | 80 | | 116 | | 152 | | 185 | | 240 | 292 |
| D8 _{hg} | - | 16 | | 22 | | 32 | | 40 | | 55 | 75 |
| L1 | 42 | 60 | | 90 | | 115 | | 142 | | 180 | 220 |
| L2 | 26 | 37 | | 48 | | 65 | | 97 | | 105 | 138 |
| L3 | 5.5 | 7 | | 10 | | 12 | | 15 | | 20 | 30 |
| L4 | 1 | 1.5 | | 1.5 | | 2 | | 3 | | 3 | 3 |
| L5 | 16 | 25 | | 32 | | 40 | | 63 | | 70 | 90 |
| L6 | 2 | 2 | | 3 | | 5 | | 5 | | 6 | 7 |
| L7 | 4 | 6 | | 8 | | 10 | | 12 | | 15 | 20 |
| L8 | 139 | 163.5 | 182 | 206.5 | 251 | 285 | 320 | 365 | 404.5 | 431 | 521 |
| L9 | 4.5 | 4.8 | | 7.2 | | 10 | | 12 | | 15 | 15 |
| L10 | 10 | 12.5 | | 19 | | 28 | | 36 | | 42 | 42 |
| L11 | - | 26 | | 26 | | 26 | | 40 | | 41.5 | 52 |
| L12 | - | 15 | | 15 | | 15 | | 20 | | 21.5 | 28 |
| L13 | - | 21 | | 22.5 | | 23 | | 33.5 | | 33.5 | 45 |
| C1 ² | 46 | 46 | 70 | 70 | 100 | 100 | 130 | 130 | 165 | 165 | 215 |
| C2 ² | M4 x 0.7P | M4 x 0.7P | M5 x 0.8P | M5 x 0.8P | M6 x 1P | M6 x 1P | M8 x 1.25P | M8 x 1.25P | M10 x 1.5P | M10 x 1.5P | M12 x 1.75P |
| C3 ² | ≤11 / ≤12 | ≤11 / ≤12 | ≤14 / ≤16 | ≤14 / ≤15.875 / ≤16 | ≤19 / ≤24 | ≤19 / ≤24 | ≤32 | ≤32 | ≤38 | ≤38 | ≤48 |
| C4 ² | 25 | 25 | 34 | 34 | 40 | 40 | 50 | 50 | 60 | 60 | 85 |
| C5 ² | 30 | 30 | 50 | 50 | 80 | 80 | 110 | 110 | 130 | 130 | 180 |
| C6 ² | 3.5 | 3.5 | 8 | 8 | 4 | 4 | 5 | 5 | 6 | 6 | 6 |
| C7 ² | 42 | 42 | 60 | 60 | 90 | 90 | 115 | 115 | 142 | 142 | 190 |
| C8 ² | 29.5 | 29.5 | 19 | 19 | 17 | 17 | 19.5 | 19.5 | 22.5 | 22.5 | 29 |
| C9 ² | 90.5 | 99.5 | 111.5 | 126.5 | 152.5 | 165 | 191.5 | 205 | 235.5 | 254.5 | 323.5 |
| C10 ² | 8.75 | 8.75 | 13.5 | 13.5 | 10.75 | 10.75 | 13 | 13 | 15 | 15 | 20.75 |
| B1 _{hg} | 5 | 5 | | 6 | | 10 | | 12 | | 16 | 20 |
| H1 | 15 | 18 | | 24.5 | | 35 | | 43 | | 59 | 79.5 |
| X DIN5480 | - | W16x0.8x 30x18x6m | | W22x1.25x 30x16x6m | | W32x1.25x 30x24x6m | | W40x2x 30x18x6m | | W55x2x 30x26x6m | W70x2x 30x34x6m |

2. C1~C10 are motor specific dimensions (metric std shown). Refer to www.apexdyna.com and Design Tool to view your specific motor mounting system.

Selection of the Optimum Gearbox

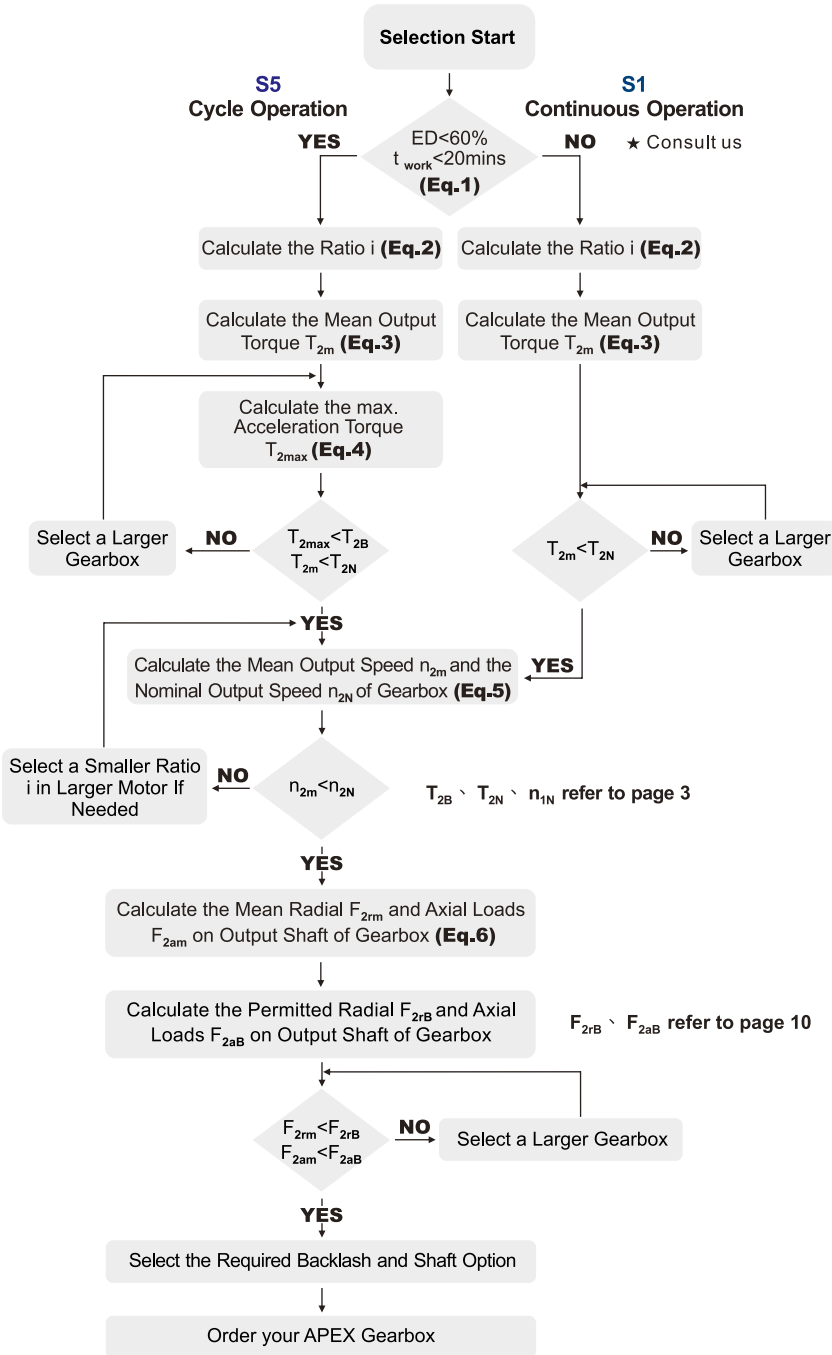

Recommended (for S5 Cycle Operation)

The general design is given for

$$\frac{J_L}{i^2} \leq 4 \times J_m$$

The optimal design is given for

$$\frac{J_L}{i^2} \cong J_m$$

J_L Load Inertia

J_m Motor Inertia

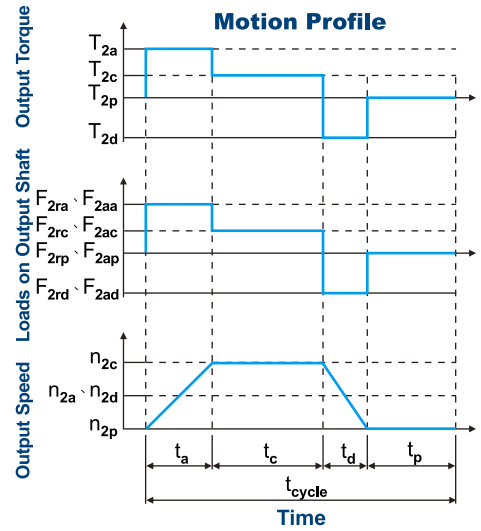

$$1. ED = \frac{t_a + t_c + t_d}{t_{cycle}} \times 100\%, t_{work} = t_a + t_c + t_d$$

Index : a. Acceleration, c. Constant, d. Deceleration, p. Pause

(Eq.1)

$$2. i \cong \frac{n_m}{n_{work}}$$

n_m Output Speed of the Motor

n_{work} Working Speed

(Eq.2)

$$3. T_{2m} = \sqrt[3]{\frac{n_{2a} \times t_a \times T_{2a}^3 + n_{2c} \times t_c \times T_{2c}^3 + n_{2d} \times t_d \times T_{2d}^3}{n_{2a} \times t_a + n_{2c} \times t_c + n_{2d} \times t_d}}$$

(Eq.3)

$$4. T_{2max} = T_{mB} \times i \times K_s \times \eta$$

where K_s is

| K_s | No. of Cycles / hr |
|-------|--------------------|
| 1.0 | 0 ~ 1,000 |
| 1.1 | 1,000 ~ 1,500 |
| 1.3 | 1,500 ~ 2,000 |
| 1.6 | 2,000 ~ 3,000 |
| 1.8 | 3,000 ~ 5,000 |

T_{mB} Max. Output Torque of the Motor

η Efficiency of the Gearbox

(Eq.4)

$$5. n_{2a} = n_{2d} = \frac{1}{2} \times n_{2c}$$

$$n_{2m} = \frac{n_{2a} \times t_a + n_{2c} \times t_c + n_{2d} \times t_d}{t_a + t_c + t_d}$$

$$n_{2N} = \frac{n_{1N}}{i}$$

(Eq.5)

$$6. F_{2rm} = \sqrt[3]{\frac{n_{2a} \times t_a \times F_{2ra}^3 + n_{2c} \times t_c \times F_{2rc}^3 + n_{2d} \times t_d \times F_{2rd}^3}{n_{2a} \times t_a + n_{2c} \times t_c + n_{2d} \times t_d}}$$

$$F_{2am} = \sqrt[3]{\frac{n_{2a} \times t_a \times F_{2aa}^3 + n_{2c} \times t_c \times F_{2ac}^3 + n_{2d} \times t_d \times F_{2ad}^3}{n_{2a} \times t_a + n_{2c} \times t_c + n_{2d} \times t_d}}$$

(Eq.6)

Permitted Radial and Axial Loads

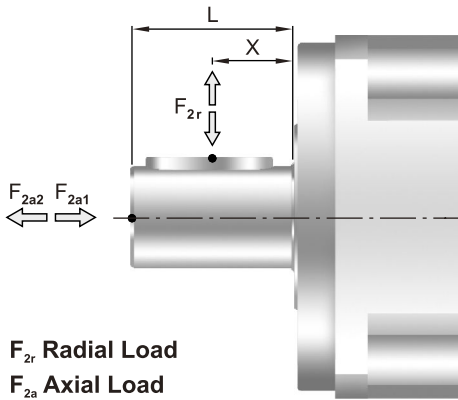

The permitted radial and axial loads on output shaft of the gearbox depend on the design of the gearbox supporting bearings. APEX use the extension straddle oversized ball bearing design. It can take heavy load from both axes.

F_{2r} Radial Load
 F_{2a} Axial Load

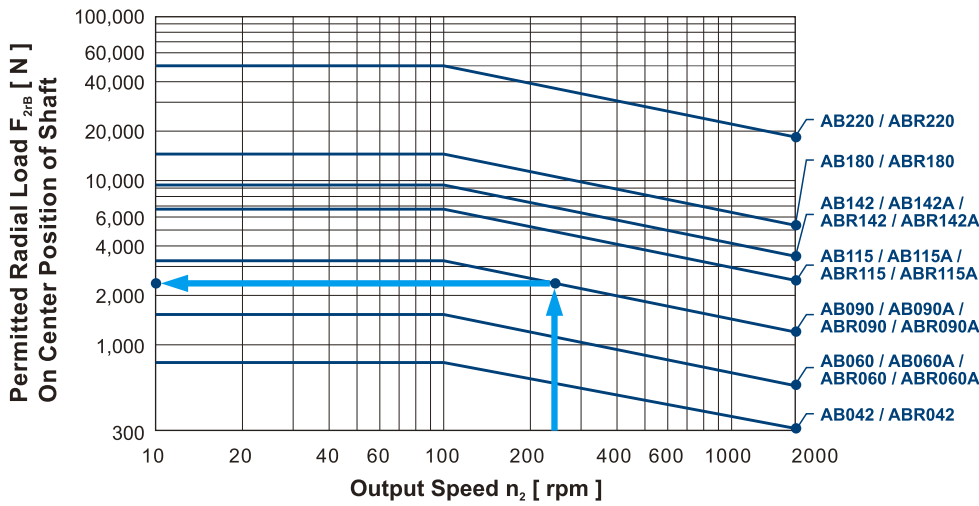

If radial force F_{2r} exert on the center of the output shaft $X=1/2 \times L$. The permitted radial load is given on left diagram.

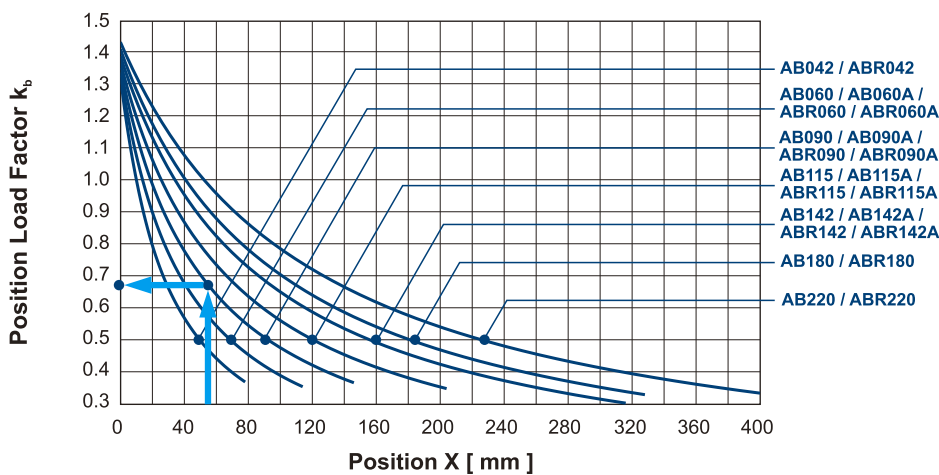

If radial force F_{2r} not exert on the center of the output shaft $X < 1/2 \times L$ or $X > 1/2 \times L$. The permitted radial and axial load can be calculated by the position load factor k_b on the left diagram.



APEX DYNAMICS, INC.

No. 10, Keyuan 3rd Rd., Situn District, Taichung City 40763, Taiwan (R.O.C.)
Tel: 886-4-24650219 | Fax: 886-4-24650118
sales@apexdyna.com | <http://www.apexdyna.com>

APEX-2019-4-AB/ABR Series - 1.0V

Printed in Taiwan

UK & Ireland Distributor



11-15 Francis Avenue, Bournemouth,
Dorset, UK, BH11 8NX
Tel.: +44 (0)1202 599922
enquiries@motioncontrolproducts.com
www.motioncontrolproducts.com