

# ADR-B SERIES

- ▶ Direct drive brushless motor
- ▶ Fully integrated with encoder and bearing
- ▶ Low cogging torque
- ▶ Precise homing through index pulse
- ▶ Low speed and high speed windings

## ADR110-B113

ADR110-B113				
Performance Parameters	Symbol	Unit	Series	Parallel
Continuous Torque @100°C	T <sub>cn</sub>	Nm	1.9	1.9
Peak Torque	T <sub>pk</sub>	Nm	5.8	5.8
Torque Constant ±10%	K <sub>t</sub>	Nm/Arms	0.65	0.32
Back EMF constant ±10%	K <sub>e</sub>	Vpeak/rpm	0.055	0.028
Motor Constant @25°C	K <sub>m</sub>	Nm/Sqrt(W)	0.30	0.30
Resistance (L-L) @25°C ±10%	R <sub>25</sub>	Ω	3.20	0.80
Inductance (L-L) ±20%	L	mH	17.15	4.29
Electrical time constant	τ <sub>e</sub>	ms	5.36	5.36
Continuous Current @100°C	I <sub>cn</sub>	Arms	3.0	6.0
Peak Current	I <sub>pk</sub>	Arms	9.0	18.0
Continuous Power Dissipation @100°C	P <sub>cn</sub>	W	55.7	55.7
Max. Coil Temperature	T <sub>max</sub>	°C	100.0	100.0
Thermal Dissipation Constant	K <sub>thn</sub>	W/°C	0.7	0.7
Max. Bus Voltage	U <sub>bus</sub>	Vdc	600.0	600.0
Pole Number	p	-	16	16
Rec. Max Speed @230V AC	Ω <sub>max</sub>	rpm	1700	2000
Mechanical Parameters				
Overall Mass	m <sub>n</sub>	kg	3.20	3.20
Rotor Inertia	J <sub>r</sub>	kg·m <sup>2</sup>	3.086E-04	3.086E-04
Axial Runout	-	μm	15	15
Radial Runout	-	μm	15	15
Max Axial Load (Upright Mounting)	-	N	439	439
Max Axial Load (Inverted / Wall mounting)	-	N	35	35
Max Moment Load (Upright Mounting)	-	Nm	25	25
Max Moment Load (Inverted / Wall Mounting)	-	Nm	2.8	2.8
Encoder Parameters				
ABI Optical Incremental Encoder (SIN/COS)	-	lines / rev	3005	3005
ABI Optical Incremental Encoder Digital Resolution (80x)	-	counts / rev	240400	240400
ABI Optical Incremental Encoder Digital Resolution (160x)	-	counts / rev	480800	480800
ABI Optical Incremental Encoder Digital Resolution (400x)	-	counts / rev	1202000	1202000
Accuracy with Error Mapping	-	arc sec	+/-5.4	+/-5.4
Repeatability	-	arc sec	+/-2.7	+/-2.7
Other Information				
Insulation Class	Class B (130°C)			
Protection Grade	IP40			
Compliance with Global Standards	RoHS, CE, UL (option)			
Ambient Temperature	Operation	0°C to 40°C (non-freezing)		
	Storage	-15°C to 70°C (non-freezing)		
Ambient Humidity	Operation	10%RH to 80%RH (non-condensing)		
	Storage	10%RH to 90%RH (non-condensing)		
Recommended Ambience	Indoor (no direct sunlight); No corrosive gas, inflammable gas, oil mist or dust.			

- ① Measurement is taken at ambient temperature 25°C. Value depends on the thermal environment.
  - ② Resistance is measured by DC current with standard 3 m cable.
  - ③ Inductance is measured by current frequency of 1 kHz.
  - ④ The value is based on ABI optical SIN/COS encoder (4096x interpolation) under maximum bus voltage.
  - ⑤ The runout value in parenthesis is optional.
  - ⑥ Please refer to the illustration for different mountings.
  - ⑦ Based on ABI optical SIN/COS encoder (4096x interpolation) with standard runout.
- The contents of datasheet are subjected to change.

### Torque-Speed Curve

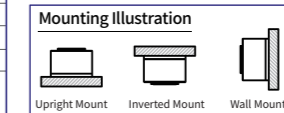
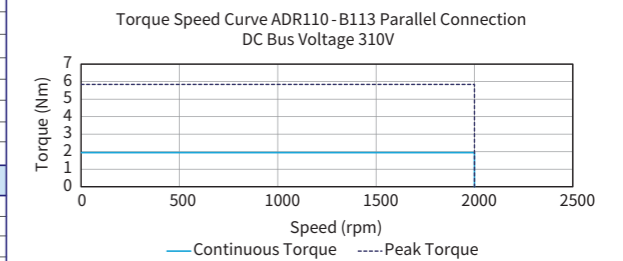
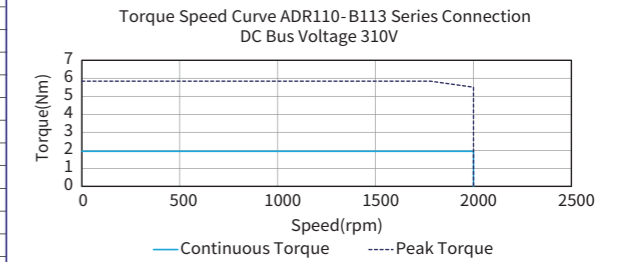

### Dimension

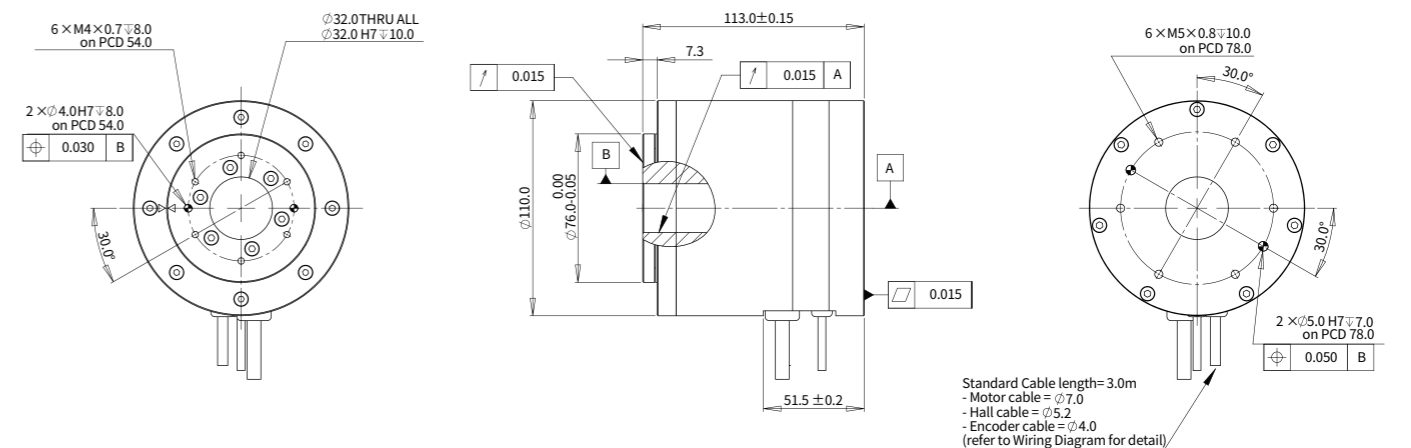

ADR110-B136

ADR110-B136				
Performance Parameters	Symbol	Unit	Series	Parallel
Continuous Torque @100°C	T <sub>cn</sub>	Nm	4.2	4.2
Peak Torque	T <sub>pk</sub>	Nm	12.6	12.6
Torque Constant ±10%	K <sub>t</sub>	Nm/Arms	1.40	0.70
Back EMF constant ±10%	K <sub>e</sub>	Vpeak/rpm	0.119	0.060
Motor Constant @25°C	K <sub>m</sub>	Nm/Sqrt(W)	0.51	0.52
Resistance (L-L) @25°C ±10%	R <sub>25</sub>	Ω	4.90	1.21
Inductance (L-L) ±20%	L	mH	26.26	6.49
Electrical time constant	τ <sub>e</sub>	ms	5.36	5.36
Continuous Current @100°C	I <sub>cn</sub>	Arms	3.0	6.0
Peak Current	I <sub>pk</sub>	Arms	9.0	18.0
Continuous Power Dissipation @100°C	P <sub>cn</sub>	W	85.3	84.2
Max. Coil Temperature	T <sub>max</sub>	°C	100.0	100.0
Thermal Dissipation Constant	K <sub>thn</sub>	W/°C	1.1	1.1
Max. Bus Voltage	U <sub>bus</sub>	Vdc	600.0	600.0
Pole Number	p	-	16	16
Rec. Max Speed @230V AC	Ω <sub>max</sub>	rpm	1000	2000

Mechanical Parameters				
Overall Mass	m <sub>n</sub>	kg	4.60	4.60
Rotor Inertia	J <sub>r</sub>	kg·m <sup>2</sup>	4.419E-04	4.419E-04
Axial Runout	-	μm	15	15
Radial Runout	-	μm	15	15
Max Axial Load (Upright Mounting)	-	N	439	439
Max Axial Load (Inverted / Wall mounting)	-	N	35	35
Max Moment Load (Upright Mounting)	-	Nm	25	25
Max Moment Load (Inverted / Wall Mounting)	-	Nm	2.8	2.8

Encoder Parameters				
ABI Optical Incremental Encoder (SIN/COS)	-	lines / rev	3005	3005
ABI Optical Incremental Encoder Digital Resolution (80x)	-	counts / rev	240400	240400
ABI Optical Incremental Encoder Digital Resolution (160x)	-	counts / rev	480800	480800
ABI Optical Incremental Encoder Digital Resolution (400x)	-	counts / rev	1202000	1202000
Accuracy with Error Mapping	-	arc sec	+/-5.4	+/-5.4
Repeatability	-	arc sec	+/-2.7	+/-2.7

Other Information				
Insulation Class	Class B (130°C)			
Protection Grade	IP40			
Compliance with Global Standards	RoHS, CE, UL (option)			
Ambient Temperature	Operation	0°C to 40°C (non-freezing)		
	Storage	-15°C to 70°C (non-freezing)		
Ambient Humidity	Operation	10%RH to 80%RH (non-condensing)		
	Storage	10%RH to 90%RH (non-condensing)		
Recommended Ambience	Indoor (no direct sunlight); No corrosive gas, inflammable gas, oil mist or dust.			

- Measurement is taken at ambient temperature 25°C. Value depends on the thermal environment.
  - Resistance is measured by DC current with standard 3 m cable.
  - Inductance is measured by current frequency of 1 kHz.
  - The value is based on ABI optical SIN/COS encoder (4096x interpolation) under maximum bus voltage.
  - The runout value in parenthesis is optional.
  - Please refer to the illustration for different mountings.
  - Based on ABI optical SIN/COS encoder (4096x interpolation) with standard runout.
- The contents of datasheet are subjected to change.

Dimension

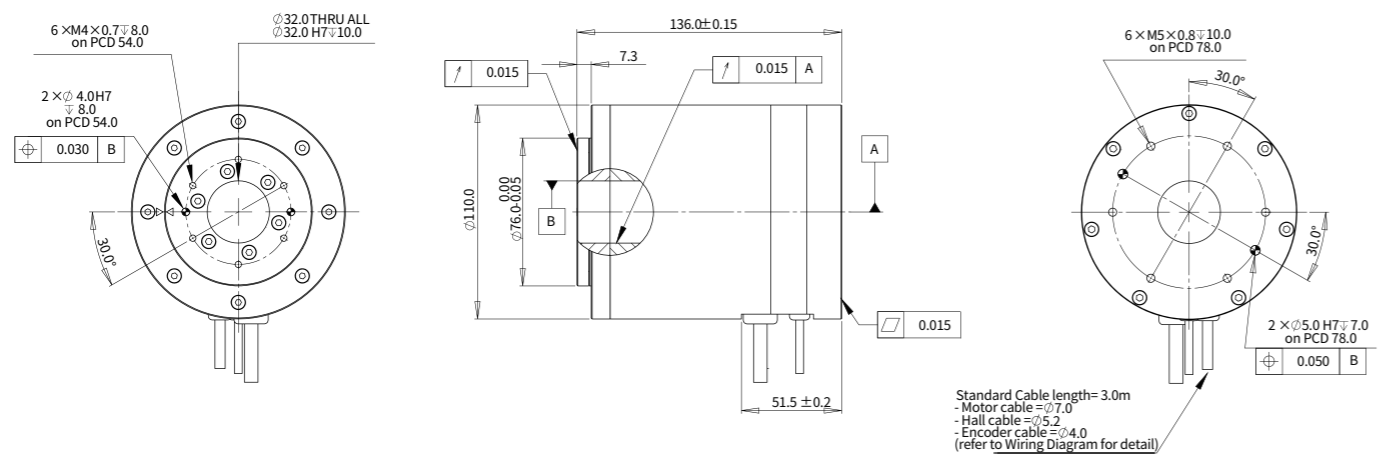

Torque-Speed Curve

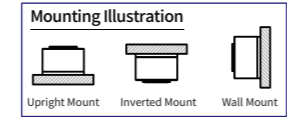
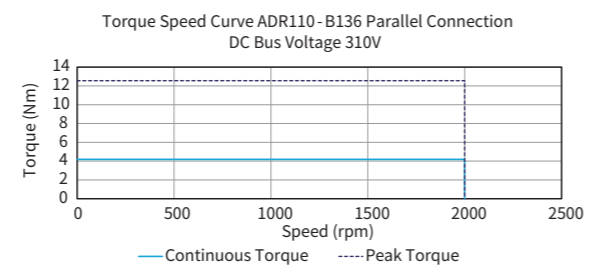
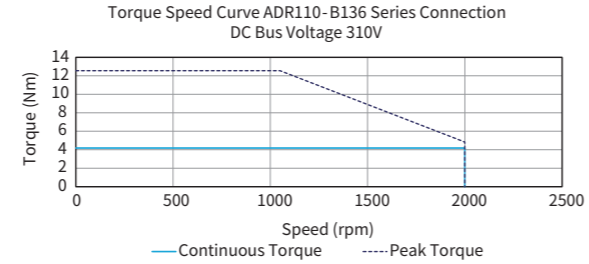

ADR135-B121

ADR135-B121				
Performance Parameters	Symbol	Unit	Series	Parallel
Continuous Torque @100°C	T <sub>cn</sub>	Nm	5.2	5.2
Peak Torque	T <sub>pk</sub>	Nm	15.5	15.5
Torque Constant ±10%	K <sub>t</sub>	Nm/Arms	1.72	0.86
Back EMF constant ±10%	K <sub>e</sub>	Vpeak/rpm	0.147	0.074
Motor Constant @25°C	K <sub>m</sub>	Nm/Sqrt(W)	0.55	0.55
Resistance (L-L) @25°C ±10%	R <sub>25</sub>	Ω	6.60	1.65
Inductance (L-L) ±20%	L	mH	45.30	11.20
Electrical time constant	τ <sub>e</sub>	ms	6.86	6.79
Continuous Current @100°C	I <sub>cn</sub>	Arms	3.0	6.0
Peak Current	I <sub>pk</sub>	Arms	9.0	18.0
Continuous Power Dissipation @100°C	P <sub>cn</sub>	W	114.9	114.9
Max. Coil Temperature	T <sub>max</sub>	°C	100.0	100.0
Thermal Dissipation Constant	K <sub>thn</sub>	W/°C	1.5	1.5
Max. Bus Voltage	U <sub>bus</sub>	Vdc	600.0	600.0
Pole Number	p	-	16	16
Rec. Max Speed @230V AC	Ω <sub>max</sub>	rpm	630	1350

Mechanical Parameters				
Overall Mass	m <sub>n</sub>	kg	3.90	3.90
Rotor Inertia	J <sub>r</sub>	kg·m <sup>2</sup>	9.916E-04	9.916E-04
Axial Runout	-	μm	15	15
Radial Runout	-	μm	15	15
Max Axial Load (Upright Mounting)	-	N	604	604
Max Axial Load (Inverted / Wall mounting)	-	N	56	56
Max Moment Load (Upright Mounting)	-	Nm	45	45
Max Moment Load (Inverted / Wall Mounting)	-	Nm	5.0	5.0

Encoder Parameters				
ABI Optical Incremental Encoder (SIN/COS)	-	lines / rev	4103	4103
ABI Optical Incremental Encoder Digital Resolution (80x)	-	counts / rev	328240	328240
ABI Optical Incremental Encoder Digital Resolution (160x)	-	counts / rev	656480	656480
ABI Optical Incremental Encoder Digital Resolution (400x)	-	counts / rev	1641200	1641200
Accuracy with Error Mapping	-	arc sec	+/-4	+/-4
Repeatability	-	arc sec	+/-2	+/-2

Other Information				
Insulation Class	Class B (130°C)			
Protection Grade	IP40			
Compliance with Global Standards	RoHS, CE, UL (option)			
Ambient Temperature	Operation	0°C to 40°C (non-freezing)		
	Storage	-15°C to 70°C (non-freezing)		
Ambient Humidity	Operation	10%RH to 80%RH (non-condensing)		
	Storage	10%RH to 90%RH (non-condensing)		
Recommended Ambience	Indoor (no direct sunlight); No corrosive gas, inflammable gas, oil mist or dust.			

- Measurement is taken at ambient temperature 25°C. Value depends on the thermal environment.
  - Resistance is measured by DC current with standard 3 m cable.
  - Inductance is measured by current frequency of 1 kHz.
  - The value is based on ABI optical SIN/COS encoder (4096x interpolation) under maximum bus voltage.
  - The runout value in parenthesis is optional.
  - Please refer to the illustration for different mountings.
  - Based on ABI optical SIN/COS encoder (4096x interpolation) with standard runout.
- The contents of datasheet are subjected to change.

Dimension

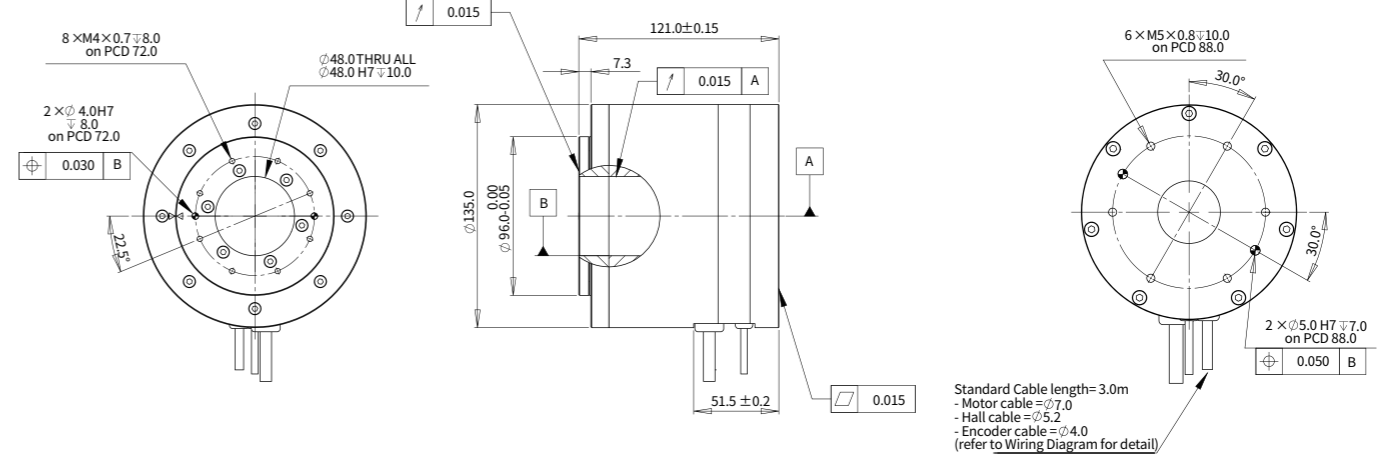

Torque-Speed Curve

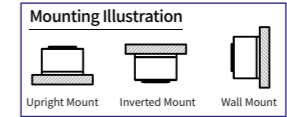
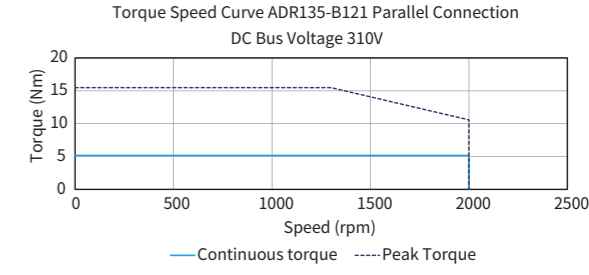
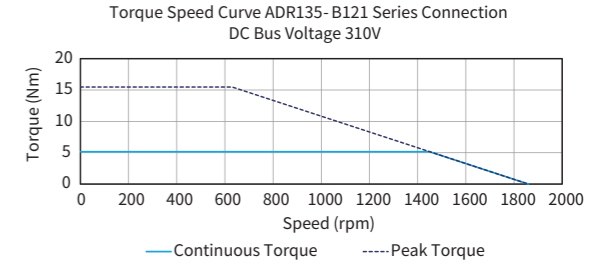

Introduction Sizing Guide Frequently Asked Questions Linear Motors Voice Coil Motors Direct Drive Rotary Motors Motion Control of Gantry Stages Akribis systems

Introduction Sizing Guide Frequently Asked Questions Linear Motors Voice Coil Motors Direct Drive Rotary Motors Motion Control of Gantry Stages Akribis systems

ADR135-B148

ADR135-B148				
Performance Parameters	Symbol	Unit	Series	Parallel
Continuous Torque @100°C	T <sub>cn</sub>	Nm	11.0	11.0
Peak Torque	T <sub>pk</sub>	Nm	32.9	32.9
Torque Constant ±10%	K <sub>t</sub>	Nm/Arms	3.66	1.83
Back EMF constant ±10%	K <sub>e</sub>	Vpeak/rpm	0.313	0.156
Motor Constant @25°C	K <sub>m</sub>	Nm/Sqrt(W)	0.91	0.91
Resistance (L-L) @25°C ±10%	R <sub>25</sub>	Ω	10.70	2.70
Inductance (L-L) ±20%	L	mH	72.76	18.63
Electrical time constant	τ <sub>e</sub>	ms	6.80	6.90
Continuous Current @100°C	I <sub>cn</sub>	Arms	3.0	6.0
Peak Current	I <sub>pk</sub>	Arms	9.0	18.0
Continuous Power Dissipation @100°C	P <sub>cn</sub>	W	186.2	187.9
Max. Coil Temperature	T <sub>max</sub>	°C	100.0	100.0
Thermal Dissipation Constant	K <sub>thn</sub>	W/°C	2.5	2.5
Max. Bus Voltage	U <sub>bus</sub>	Vdc	600.0	600.0
Pole Number	p	-	16	16
Rec. Max Speed @230V AC	Ω <sub>max</sub>	rpm	330	745
Mechanical Parameters				
Overall Mass	m <sub>n</sub>	kg	5.70	5.70
Rotor Inertia	J <sub>r</sub>	kg·m <sup>2</sup>	1.332E-03	1.332E-03
Axial Runout	-	μm	15	15
Radial Runout	-	μm	15	15
Max Axial Load (Upright Mounting)	-	N	604	604
Max Axial Load (Inverted / Wall mounting)	-	N	56	56
Max Moment Load (Upright Mounting)	-	Nm	45	45
Max Moment Load (Inverted / Wall Mounting)	-	Nm	5.0	5.0
Encoder Parameters				
ABI Optical Incremental Encoder (SIN/COS)	-	lines / rev	4103	4103
ABI Optical Incremental Encoder Digital Resolution (80x)	-	counts / rev	328240	328240
ABI Optical Incremental Encoder Digital Resolution (160x)	-	counts / rev	656480	656480
ABI Optical Incremental Encoder Digital Resolution (400x)	-	counts / rev	1641200	1641200
Accuracy with Error Mapping	-	arc sec	+/-4	+/-4
Repeatability	-	arc sec	+/-2	+/-2
Other Information				
Insulation Class	Class B (130°C)			
Protection Grade	IP40			
Compliance with Global Standards	RoHS, CE, UL (option)			
Ambient Temperature	Operation	0°C to 40°C (non-freezing)		
	Storage	-15°C to 70°C (non-freezing)		
Ambient Humidity	Operation	10%RH to 80%RH (non-condensing)		
	Storage	10%RH to 90%RH (non-condensing)		
Recommended Ambience	Indoor (no direct sunlight); No corrosive gas, inflammable gas, oil mist or dust.			

Torque-Speed Curve

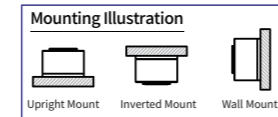
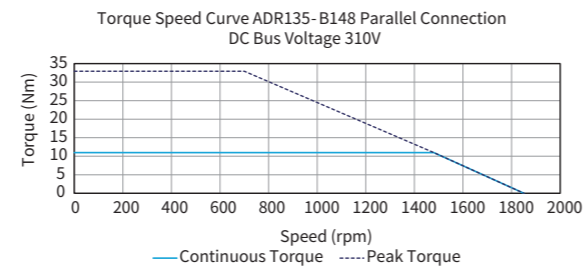
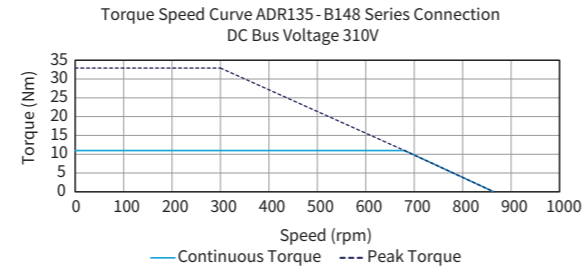

- ① Measurement is taken at ambient temperature 25°C. Value depends on the thermal environment.
  - ② Resistance is measured by DC current with standard 3 m cable.
  - ③ Inductance is measured by current frequency of 1 kHz.
  - ④ The value is based on ABI optical SIN/COS encoder (4096x interpolation) under maximum bus voltage.
  - ⑤ The runout value in parenthesis is optional.
  - ⑥ Please refer to the illustration for different mountings.
  - ⑦ Based on ABI optical SIN/COS encoder (4096x interpolation) with standard runout.
- The contents of datasheet are subjected to change.

Dimension

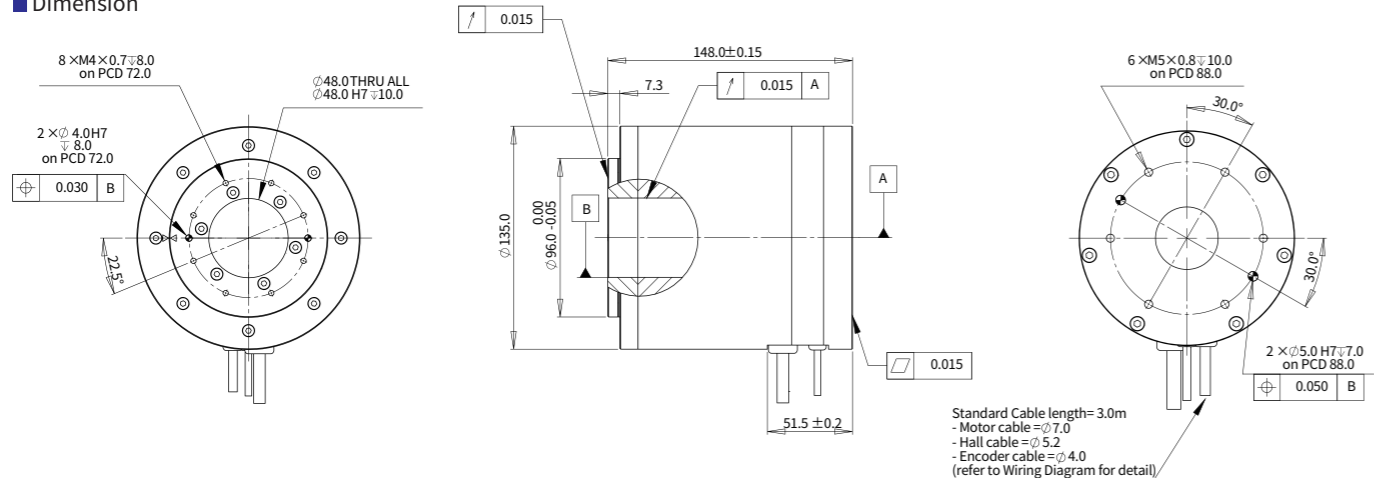

ADR175-B143

ADR175-B143				
Performance Parameters	Symbol	Unit	Series	Parallel
Continuous Torque @100°C	T <sub>cn</sub>	Nm	15.7	15.7
Peak Torque	T <sub>pk</sub>	Nm	47.2	47.2
Torque Constant ±10%	K <sub>t</sub>	Nm/Arms	3.93	1.97
Back EMF constant ±10%	K <sub>e</sub>	Vpeak/rpm	0.336	0.168
Motor Constant @25°C	K <sub>m</sub>	Nm/Sqrt(W)	1.40	1.41
Resistance (L-L) @25°C ±10%	R <sub>25</sub>	Ω	5.27	1.30
Inductance (L-L) ±20%	L	mH	45.72	11.27
Electrical time constant	τ <sub>e</sub>	ms	8.67	8.67
Continuous Current @100°C	I <sub>cn</sub>	Arms	4.0	8.0
Peak Current	I <sub>pk</sub>	Arms	12.0	24.0
Continuous Power Dissipation @100°C	P <sub>cn</sub>	W	163.1	160.9
Max. Coil Temperature	T <sub>max</sub>	°C	100.0	100.0
Thermal Dissipation Constant	K <sub>thn</sub>	W/°C	2.2	2.1
Max. Bus Voltage	U <sub>bus</sub>	Vdc	600.0	600.0
Pole Number	p	-	16	16
Rec. Max Speed @230V AC	Ω <sub>max</sub>	rpm	400	880
Mechanical Parameters				
Overall Mass	m <sub>n</sub>	kg	10.0	10.0
Rotor Inertia	J <sub>r</sub>	kg·m <sup>2</sup>	5.422E-03	5.422E-03
Axial Runout	-	μm	20	20
Radial Runout	-	μm	20	20
Max Axial Load (Upright Mounting)	-	N	1256	1256
Max Axial Load (Inverted / Wall mounting)	-	N	84	84
Max Moment Load (Upright Mounting)	-	Nm	65	65
Max Moment Load (Inverted / Wall Mounting)	-	Nm	7.2	7.2
Encoder Parameters				
ABI Optical Incremental Encoder (SIN/COS)	-	lines / rev	5071	5071
ABI Optical Incremental Encoder Digital Resolution (80x)	-	counts / rev	405680	405680
ABI Optical Incremental Encoder Digital Resolution (160x)	-	counts / rev	811360	811360
ABI Optical Incremental Encoder Digital Resolution (400x)	-	counts / rev	2028400	2028400
Accuracy with Error Mapping	-	arc sec	+/-4	+/-4
Repeatability	-	arc sec	+/-2	+/-2
Other Information				
Insulation Class	Class B (130°C)			
Protection Grade	IP40			
Compliance with Global Standards	RoHS, CE, UL (option)			
Ambient Temperature	Operation	0°C to 40°C (non-freezing)		
	Storage	-15°C to 70°C (non-freezing)		
Ambient Humidity	Operation	10%RH to 80%RH (non-condensing)		
	Storage	10%RH to 90%RH (non-condensing)		
Recommended Ambience	Indoor (no direct sunlight); No corrosive gas, inflammable gas, oil mist or dust.			

Torque-Speed Curve

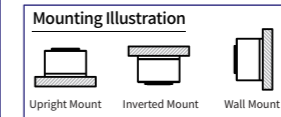
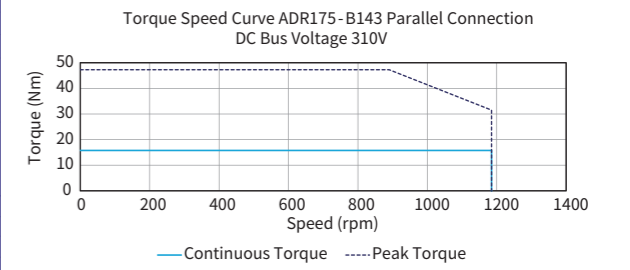
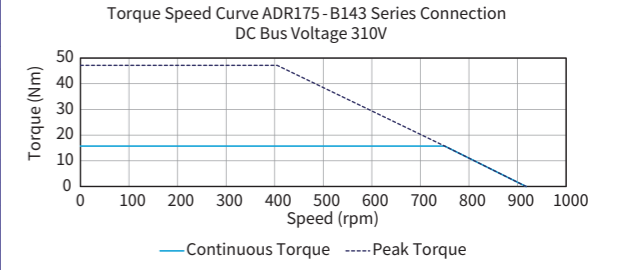

- ① Measurement is taken at ambient temperature 25°C. Value depends on the thermal environment.
  - ② Resistance is measured by DC current with standard 3 m cable.
  - ③ Inductance is measured by current frequency of 1 kHz.
  - ④ The value is based on ABI optical SIN/COS encoder (4096x interpolation) under maximum bus voltage.
  - ⑤ The runout value in parenthesis is optional.
  - ⑥ Please refer to the illustration for different mountings.
  - ⑦ Based on ABI optical SIN/COS encoder (4096x interpolation) with standard runout.
- The contents of datasheet are subjected to change.

Dimension

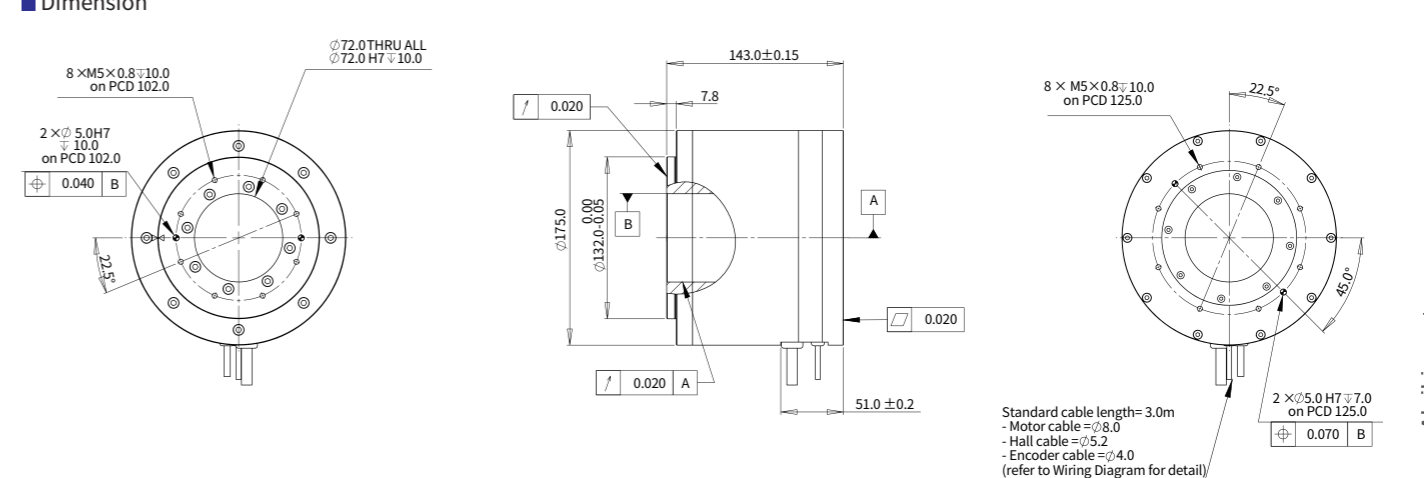

ADR175-B180

ADR175-B180				
Performance Parameters	Symbol	Unit	Series	Parallel
Continuous Torque @100°C	T <sub>cn</sub>	Nm	32.9	32.9
Peak Torque	T <sub>pk</sub>	Nm	98.6	98.6
Torque Constant ±10%	K <sub>t</sub>	Nm/Arms	8.22	4.11
Back EMF constant ±10%	K <sub>e</sub>	Vpeak/rpm	0.703	0.351
Motor Constant @25°C	K <sub>m</sub>	Nm/Sqrt(W)	2.33	2.30
Resistance (L-L) @25°C ±10%	R <sub>25</sub>	Ω	8.30	2.13
Inductance (L-L) ±20%	L	mH	72.00	18.51
Electrical time constant	τ <sub>e</sub>	ms	8.67	8.67
Continuous Current @100°C	I <sub>cn</sub>	Arms	4.0	8.0
Peak Current	I <sub>pk</sub>	Arms	12.0	24.0
Continuous Power Dissipation @100°C	P <sub>cn</sub>	W	256.8	264.2
Max. Coil Temperature	T <sub>max</sub>	°C	100.0	100.0
Thermal Dissipation Constant	K <sub>thn</sub>	W/°C	3.4	3.5
Max. Bus Voltage	U <sub>bus</sub>	Vdc	600.0	600.0
Pole Number	p	-	16	16
Rec. Max Speed @230V AC	Ω <sub>max</sub>	rpm	195	470
Mechanical Parameters				
Overall Mass	m <sub>n</sub>	kg	11.6	11.6
Rotor Inertia	J <sub>r</sub>	kg·m <sup>2</sup>	7.621E-03	7.621E-03
Axial Runout	-	μm	20	20
Radial Runout	-	μm	20	20
Max Axial Load (Upright Mounting)	-	N	1256	1256
Max Axial Load (Inverted / Wall mounting)	-	N	84	84
Max Moment Load (Upright Mounting)	-	Nm	65	65
Max Moment Load (Inverted / Wall Mounting)	-	Nm	7.2	7.2
Encoder Parameters				
ABI Optical Incremental Encoder (SIN/COS)	-	lines / rev	5071	5071
ABI Optical Incremental Encoder Digital Resolution (80x)	-	counts / rev	405680	405680
ABI Optical Incremental Encoder Digital Resolution (160x)	-	counts / rev	811360	811360
ABI Optical Incremental Encoder Digital Resolution (400x)	-	counts / rev	2028400	2028400
Accuracy with Error Mapping	-	arc sec	+/-4	+/-4
Repeatability	-	arc sec	+/-2	+/-2
Other Information				
Insulation Class	Class B (130°C)			
Protection Grade	IP40			
Compliance with Global Standards	RoHS, CE, UL (option)			
Ambient Temperature	Operation	0°C to 40°C (non-freezing)		
	Storage	-15°C to 70°C (non-freezing)		
Ambient Humidity	Operation	10%RH to 80%RH (non-condensing)		
	Storage	10%RH to 90%RH (non-condensing)		
Recommended Ambience	Indoor (no direct sunlight); No corrosive gas, inflammable gas, oil mist or dust.			

- ① Measurement is taken at ambient temperature 25°C. Value depends on the thermal environment.
  - ② Resistance is measured by DC current with standard 3 m cable.
  - ③ Inductance is measured by current frequency of 1 kHz.
  - ④ The value is based on ABI optical SIN/COS encoder (4096x interpolation) under maximum bus voltage.
  - ⑤ The runout value in parenthesis is optional.
  - ⑥ Please refer to the illustration for different mountings.
  - ⑦ Based on ABI optical SIN/COS encoder (4096x interpolation) with standard runout.
- The contents of datasheet are subjected to change.

Dimension

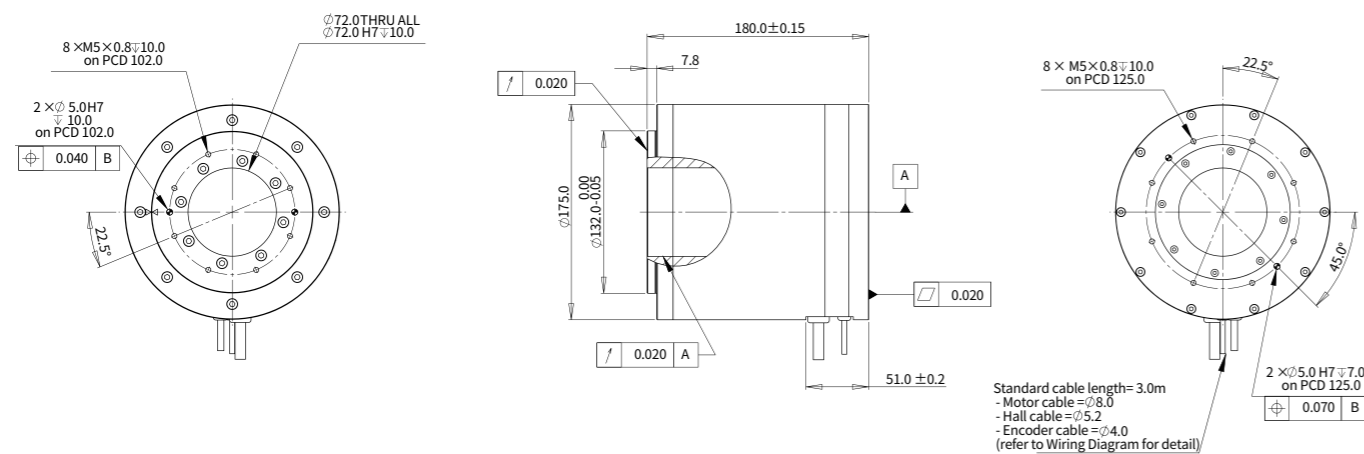

Torque-Speed Curve

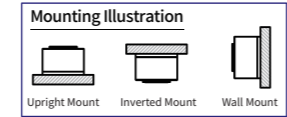
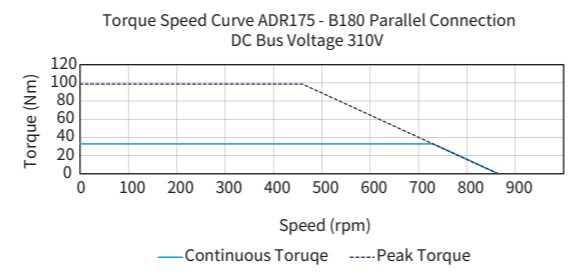
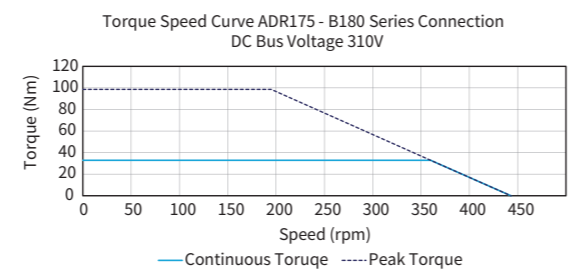

ADR220-B167

ADR220-B167				
Performance Parameters	Symbol	Unit	Series	Parallel
Continuous Torque @100°C	T <sub>cn</sub>	Nm	46.0	46.0
Peak Torque	T <sub>pk</sub>	Nm	137.9	137.9
Torque Constant ±10%	K <sub>t</sub>	Nm/Arms	8.51	2.84
Back EMF constant ±10%	K <sub>e</sub>	Vpeak/rpm	0.727	0.242
Motor Constant @25°C	K <sub>m</sub>	Nm/Sqrt(W)	2.87	2.69
Resistance (L-L) @25°C ±10%	R <sub>25</sub>	Ω	5.87	0.74
Inductance (L-L) ±20%	L	mH	53.60	6.30
Electrical time constant	τ <sub>e</sub>	ms	9.13	8.51
Continuous Current @100°C	I <sub>cn</sub>	Arms	5.40	16.20
Peak Current	I <sub>pk</sub>	Arms	16.2	48.6
Continuous Power Dissipation @100°C	P <sub>cn</sub>	W	331.0	375.5
Max. Coil Temperature	T <sub>max</sub>	°C	100.0	100.0
Thermal Dissipation Constant	K <sub>thn</sub>	W/°C	4.4	5.0
Max. Bus Voltage	U <sub>bus</sub>	Vdc	600.0	600.0
Pole Number	p	-	24	24
Rec. Max Speed @230V AC	Ω <sub>max</sub>	rpm	150	540
Mechanical Parameters				
Overall Mass	m <sub>n</sub>	kg	15.6	15.6
Rotor Inertia	J <sub>r</sub>	kg·m <sup>2</sup>	1.786E-02	1.786E-02
Axial Runout	-	μm	25	25
Radial Runout	-	μm	25	25
Max Axial Load (Upright Mounting)	-	N	1669	1669
Max Axial Load (Inverted / Wall mounting)	-	N	105	105
Max Moment Load (Upright Mounting)	-	Nm	85	85
Max Moment Load (Inverted / Wall Mounting)	-	Nm	9.4	9.4
Encoder Parameters				
ABI Optical Incremental Encoder (SIN/COS)	-	lines / rev	5071	5071
ABI Optical Incremental Encoder Digital Resolution (80x)	-	counts / rev	405680	405680
ABI Optical Incremental Encoder Digital Resolution (160x)	-	counts / rev	811360	811360
ABI Optical Incremental Encoder Digital Resolution (400x)	-	counts / rev	2028400	2028400
Accuracy with Error Mapping	-	arc sec	+/-4	+/-4
Repeatability	-	arc sec	+/-2	+/-2
Other Information				
Insulation Class	Class B (130°C)			
Protection Grade	IP40			
Compliance with Global Standards	RoHS, CE, UL (option)			
Ambient Temperature	Operation	0°C to 40°C (non-freezing)		
	Storage	-15°C to 70°C (non-freezing)		
Ambient Humidity	Operation	10%RH to 80%RH (non-condensing)		
	Storage	10%RH to 90%RH (non-condensing)		
Recommended Ambience	Indoor (no direct sunlight); No corrosive gas, inflammable gas, oil mist or dust.			

- ① Measurement is taken at ambient temperature 25°C. Value depends on the thermal environment.
  - ② Resistance is measured by DC current with standard 3 m cable.
  - ③ Inductance is measured by current frequency of 1 kHz.
  - ④ The value is based on ABI optical SIN/COS encoder (4096x interpolation) under maximum bus voltage.
  - ⑤ The runout value in parenthesis is optional.
  - ⑥ Please refer to the illustration for different mountings.
  - ⑦ Based on ABI optical SIN/COS encoder (4096x interpolation) with standard runout.
- The contents of datasheet are subjected to change.

Dimension

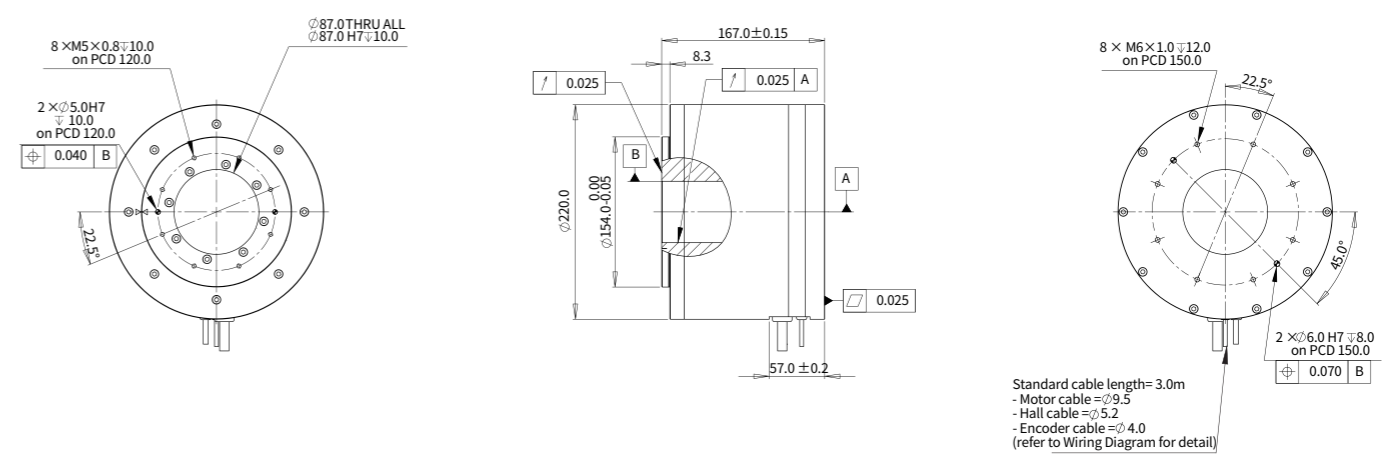

Torque-Speed Curve

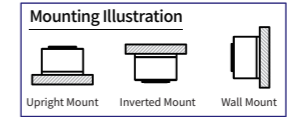
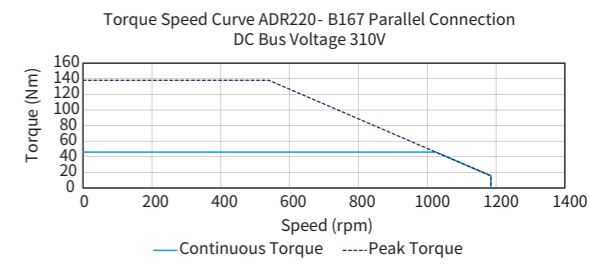
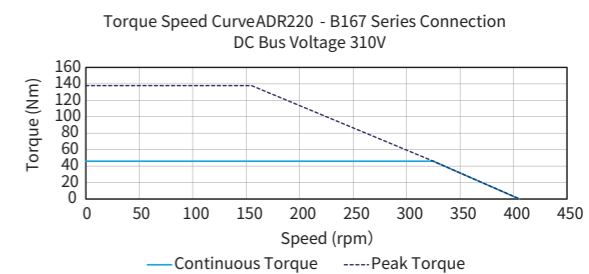

Introduction Sizing Guide Frequently Asked Questions Linear Motors Voice Coil Motors Direct Drive Rotary Motors Motion Control of Gantry Stages Akribis systems

Introduction Sizing Guide Frequently Asked Questions Linear Motors Voice Coil Motors Direct Drive Rotary Motors Motion Control of Gantry Stages Akribis systems

ADR220-B217

ADR220-B217				
Performance Parameters	Symbol	Unit	Series	Parallel
Continuous Torque @100°C	T <sub>cn</sub>	Nm	94.9	94.9
Peak Torque	T <sub>pk</sub>	Nm	284.6	284.6
Torque Constant ±10%	K <sub>t</sub>	Nm/Arms	17.57	5.86
Back EMF constant ±10%	K <sub>e</sub>	Vpeak/rpm	1.502	0.501
Motor Constant @25°C	K <sub>m</sub>	Nm/Sqrt(W)	4.47	4.37
Resistance (L-L) @25°C ±10%	R <sub>25</sub>	Ω	10.32	1.20
Inductance (L-L) ±20%	L	mH	106.70	11.90
Electrical time constant	τ <sub>e</sub>	ms	10.34	9.92
Continuous Current @100°C	I <sub>cn</sub>	Arms	5.40	16.20
Peak Current	I <sub>pk</sub>	Arms	16.2	48.6
Continuous Power Dissipation @100°C	P <sub>cn</sub>	W	581.9	608.9
Max. Coil Temperature	T <sub>max</sub>	°C	100.0	100.0
Thermal Dissipation Constant	K <sub>thn</sub>	W/°C	7.8	8.1
Max. Bus Voltage	U <sub>bus</sub>	Vdc	600.0	600.0
Pole Number	p	-	24	24
Rec. Max Speed @230V AC	Ω <sub>max</sub>	rpm	50	260

Mechanical Parameters				
Overall Mass	m <sub>n</sub>	kg	23.4	23.4
Rotor Inertia	J <sub>r</sub>	kg·m <sup>2</sup>	2.522E-02	2.522E-02
Axial Runout	-	μm	25	25
Radial Runout	-	μm	25	25
Max Axial Load (Upright Mounting)	-	N	1669	1669
Max Axial Load (Inverted / Wall mounting)	-	N	105	105
Max Moment Load (Upright Mounting)	-	Nm	85	85
Max Moment Load (Inverted / Wall Mounting)	-	Nm	9.4	9.4

Encoder Parameters				
ABI Optical Incremental Encoder (SIN/COS)	-	lines / rev	5071	5071
ABI Optical Incremental Encoder Digital Resolution (80x)	-	counts / rev	405680	405680
ABI Optical Incremental Encoder Digital Resolution (160x)	-	counts / rev	811360	811360
ABI Optical Incremental Encoder Digital Resolution (400x)	-	counts / rev	2028400	2028400
Accuracy with Error Mapping	-	arc sec	+/-4	+/-4
Repeatability	-	arc sec	+/-2	+/-2

Other Information				
Insulation Class	Class B (130°C)			
Protection Grade	IP40			
Compliance with Global Standards	RoHS, CE, UL (option)			
Ambient Temperature	Operation	0°C to 40°C (non-freezing)		
	Storage	-15°C to 70°C (non-freezing)		
Ambient Humidity	Operation	10%RH to 80%RH (non-condensing)		
	Storage	10%RH to 90%RH (non-condensing)		
Recommended Ambience	Indoor (no direct sunlight); No corrosive gas, inflammable gas, oil mist or dust.			

- Measurement is taken at ambient temperature 25°C. Value depends on the thermal environment.
  - Resistance is measured by DC current with standard 3 m cable.
  - Inductance is measured by current frequency of 1 kHz.
  - The value is based on ABI optical SIN/COS encoder (4096x interpolation) under maximum bus voltage.
  - The runout value in parenthesis is optional.
  - Please refer to the illustration for different mountings.
  - Based on ABI optical SIN/COS encoder (4096x interpolation) with standard runout.
- The contents of datasheet are subjected to change.

Dimension

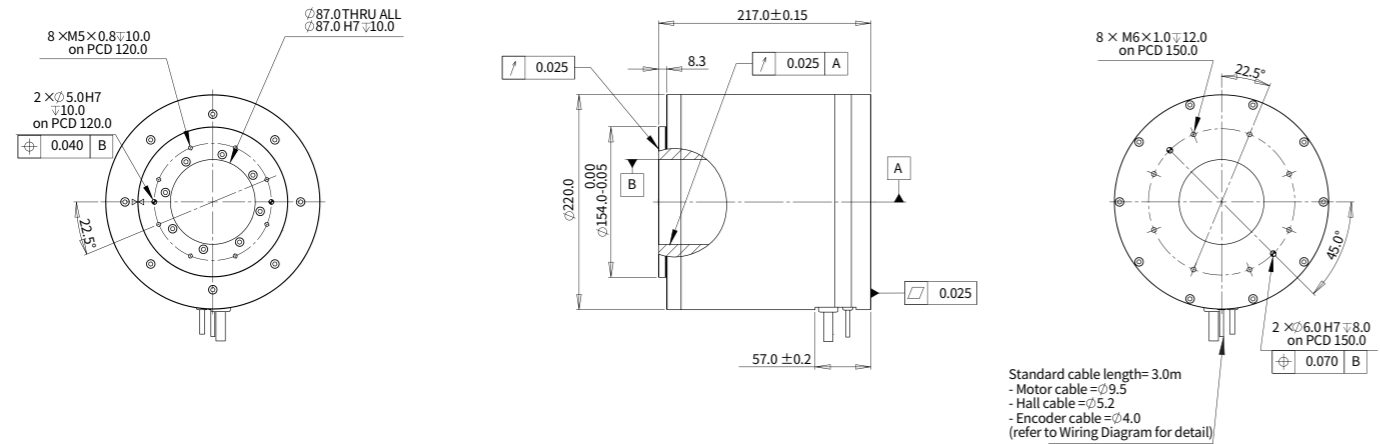

Torque-Speed Curve

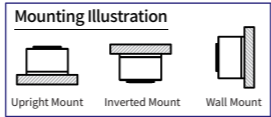
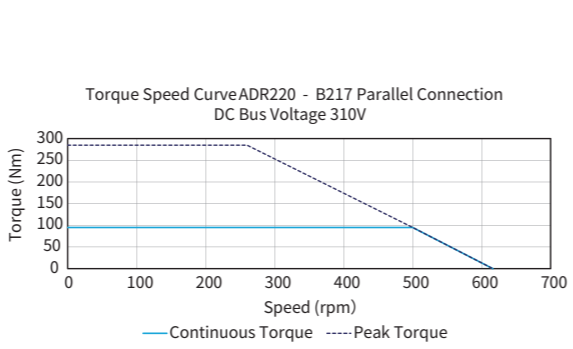
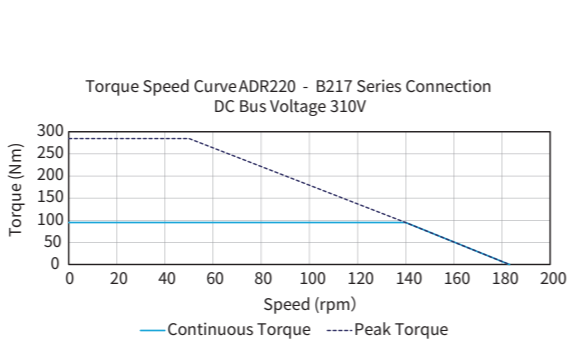

Motor Cable Connection

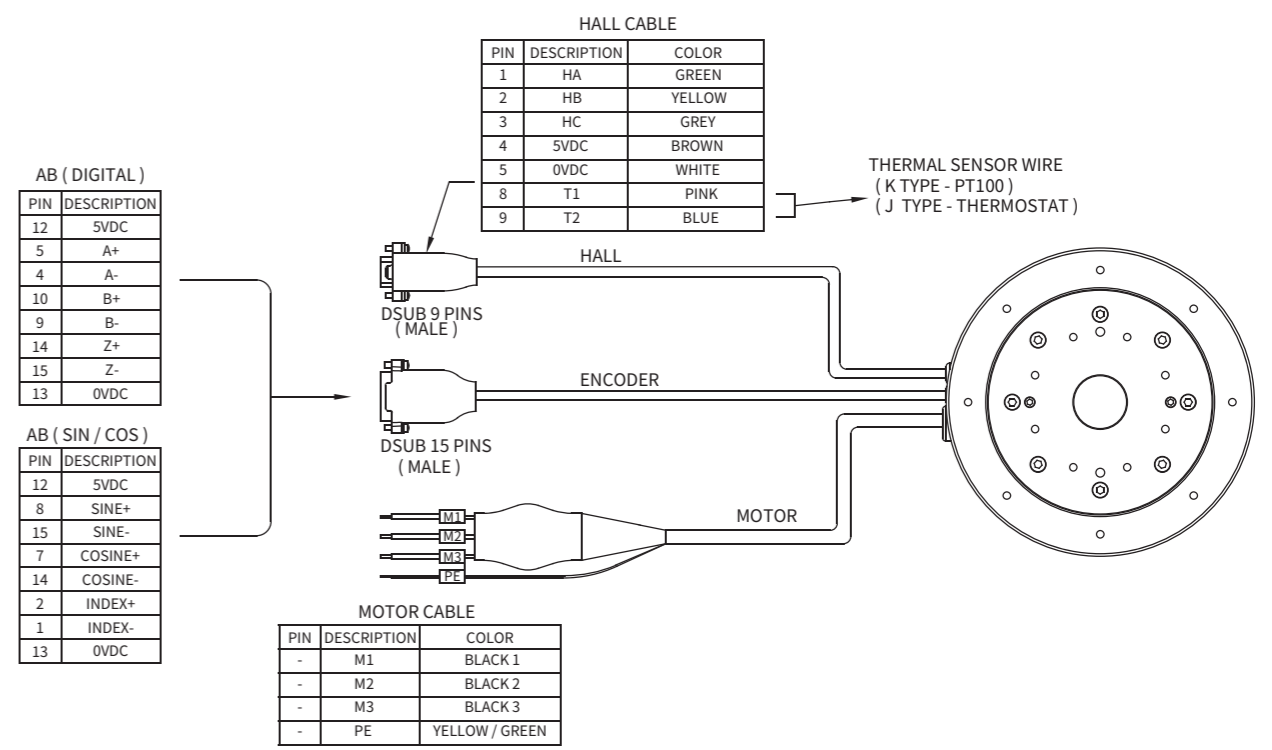

Part Numbering

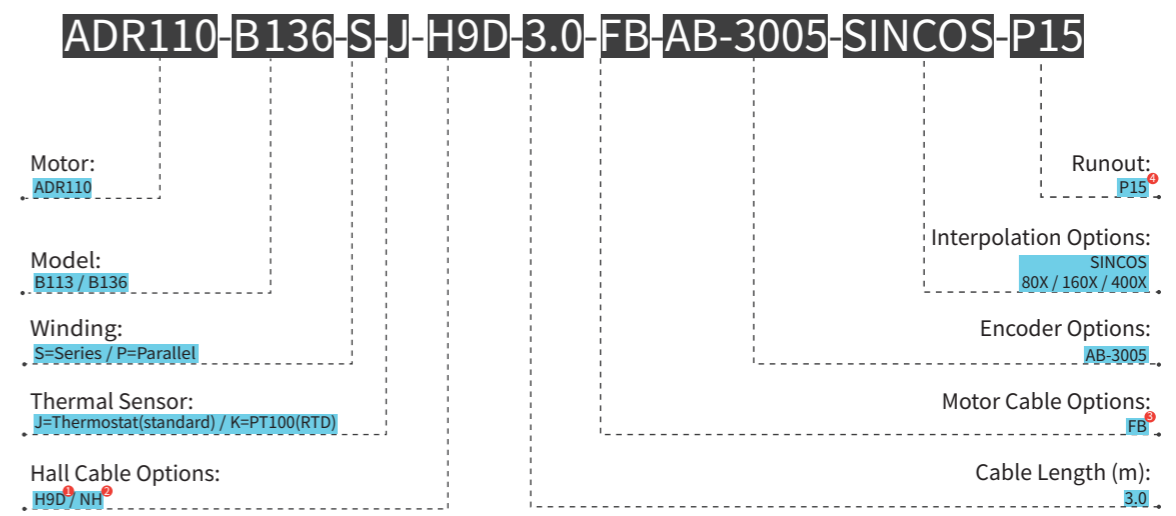

- H9D = With Built-in hall sensor, comes with 9-Pins D-Sub Connector.
- NH = Without Built-in Hall Sensor but with Thermal Sensor.
- FB = With ferrite bead.
- P15 = Axial Runout 15μm, Radial Runout is 15μm.

Introduction Sizing Guide Frequently Asked Questions Linear Motors Voice Coil Motors Direct Drive Rotary Motors Motion Control of Gantry Stages Akribis systems

Introduction Sizing Guide Frequently Asked Questions Linear Motors Voice Coil Motors Direct Drive Rotary Motors Motion Control of Gantry Stages Akribis systems

## ADR135-B121-S-J-H9D-3.0-FB-AB-4103-SINCOS-P15

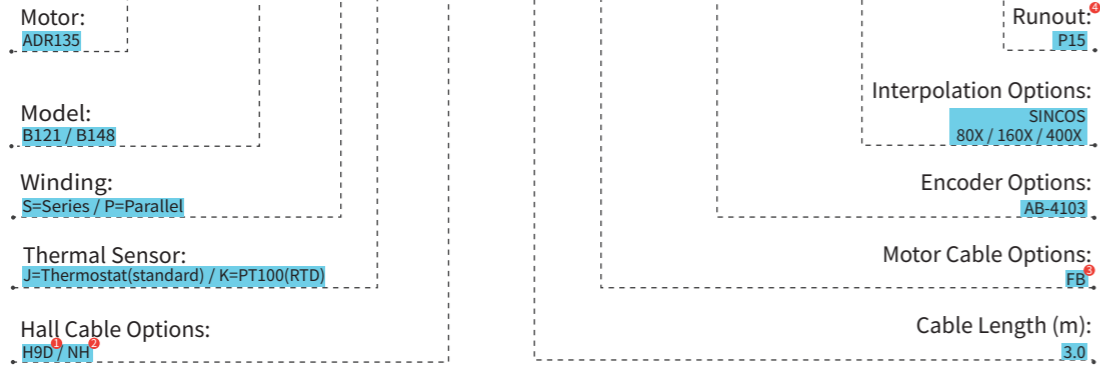

- ① H9D = With Built-in hall sensor, comes with 9-Pins D-Sub Connector.
- ② NH = Without Built-in Hall Sensor but with Thermal Sensor.
- ③ FB = With ferrite bead.
- ④ P15 = Axial Runout 15um, Radial Runout is 15um.

## ADR175-B180-P-J-NH-3.0-FB-AB-5071-SINCOS-P20

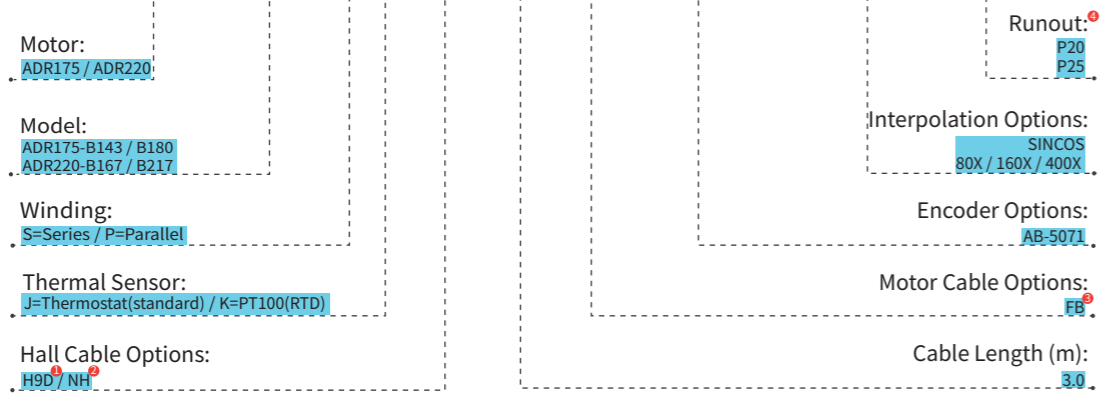

- ① H9D = With Built-in hall sensor, comes with 9-Pins D-Sub Connector.
- ② NH = Without Built-in Hall Sensor but with Thermal Sensor.
- ③ FB = With ferrite bead.
- ④ ADR175 : P20 = Axial Runout 20um, Radial Runout is 20um.  
ADR220 : P25 = Axial Runout 25um, Radial Runout is 25um.

