

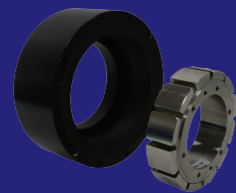

ACD SERIES

- ▶ Direct drive zero cogging coreless motor
- ▶ Precise homing through index pulse
- ▶ No cogging torque
- ▶ Smooth motion even at low speeds (low velocity ripple)



Note: Frameless ACD-P series motors are available, consisting of only rotors and stators.

ACD62-60

ACD62-60				
Performance Parameters	Symbol	Unit	D	Y
Continuous Torque @100°C	T _{cn}	Nm	0.115	0.115
Peak Torque	T _{pk}	Nm	0.40	0.40
Torque Constant ±10%	K _t	Nm/Arms	0.024	0.042
Back EMF Constant ±10%	K _e	Vpeak/rpm	0.002	0.004
Motor Constant @25°C	K _m	Nm/Sqrt(W)	0.023	0.028
Resistance (L-L) @25°C ±10%	R ₂₅	Ω	0.73	1.51
Inductance (L-L) ±20%	L	mH	0.073	0.195
Electrical Time Constant	T _e	ms	0.10	0.13
Continuous Current @100°C	I _{cn}	Arms	4.8	2.8
Peak Current	I _{pk}	Arms	16.8	9.7
Continuous Power Dissipation @100°C	P _{cn}	W	32.6	22.4
Max. Coil Temperature	t _{max}	°C	100	100
Thermal Dissipation Constant	K _{thn}	W/°C	0.435	0.298
Max. Bus Voltage	U _{bus}	Vdc	48.0	48.0
Pole Number	2P	-	8	8
Rec. Max. Speed @48 VDC (Digital / SINCOS)	Ω _{max}	rpm	1200	1200
Mechanical Parameters				
Overall Mass	m _n	kg	0.50	0.50
Rotor Inertia	J _r	kg·m ²	2.157E-05	2.157E-05
Axial Runout	-	μm	12	12
Radial Runout	-	μm	10	10
Max. Axial Load (Upright Mounting)	-	N	50	50
Max. Axial Load (Inverted / Wall Mounting)	-	N	5	5
Max. Moment Load (Upright Mounting)	-	Nm	0.3	0.3
Max. Moment Load (Inverted / Wall Mounting)	-	Nm	0.05	0.05
Encoder Parameters				
ABI Optical Incremental Encoder (SIN/COS)	-	lines / rev	1620	1620
ABI Optical Incremental Encoder (80x)	-	counts / rev	129600	129600
ABI Optical Incremental Encoder (160x)	-	counts / rev	259200	259200
ABI Optical Incremental Encoder (400x)	-	counts / rev	648000	648000
Accuracy after Error Mapping	-	arc sec	+/-6	+/-6
Repeatability	-	arc sec	+/-3	+/-3
Other Information				
Insulation Class	Class B (130°C)			
Protection Grade	IP40			
Compliance with Global Standards	RoHS, CE			
Ambient Temperature	Operation	0°C to 40°C (non-freezing)		
	Storage	-15°C to 70°C (non-freezing)		
Ambient Humidity	Operation	10%RH to 80%RH (non-condensing)		
	Storage	10%RH to 90%RH (non-condensing)		
Recommended Ambience	Indoor (no direct sunlight); No corrosive gas, inflammable gas, oil mist or dust.			

- Measurement is taken at ambient temperature 25°C. Value depends on the thermal environment.
 - Resistance is measured by DC current with standard 3 m cable.
 - Inductance is measured by current frequency of 1 kHz.
 - The value is based on ABI optical SIN/COS encoder (4096x interpolation) under max. bus voltage.
 - The runout value in parenthesis is optional.
 - Please refer to the illustration for different mountings.
 - Based on ABI optical SIN/COS encoder (4096x interpolation) with standard runout.
- The contents of datasheet are subjected to change without prior notice.

Dimension

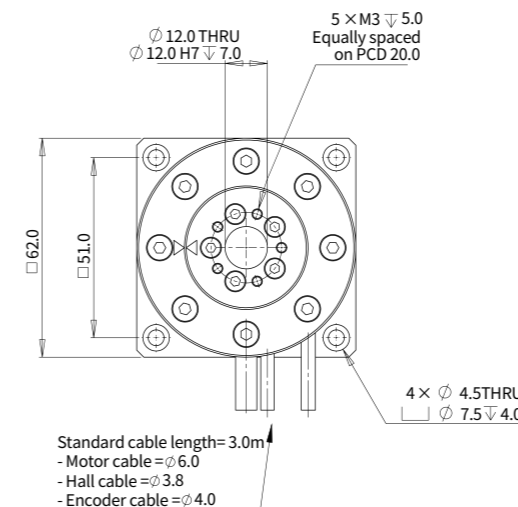

Torque-Speed Curve

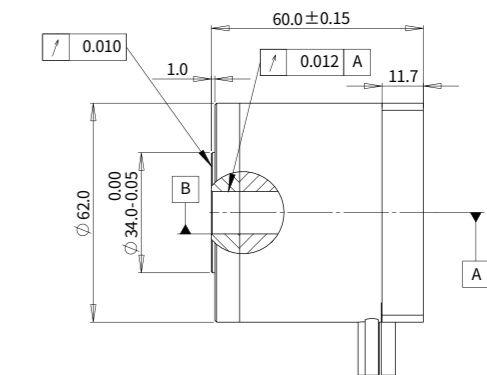
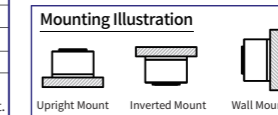
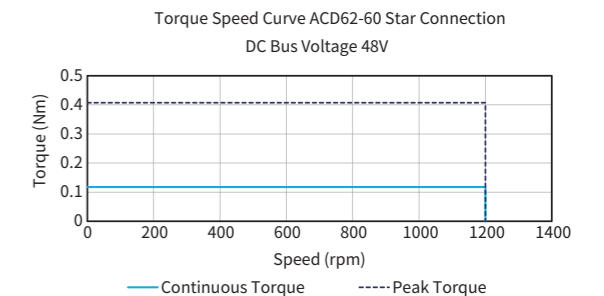
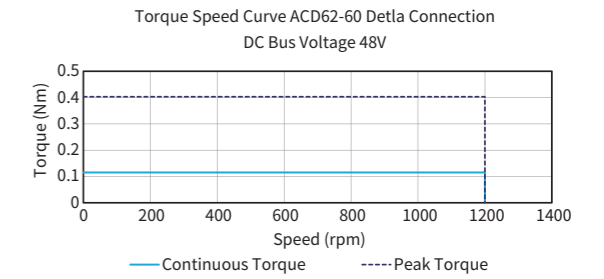

ACD62-84

ACD62-84				
Performance Parameters	Symbol	Unit	D	Y
Continuous Torque @100°C	T _{cn}	Nm	0.341	0.341
Peak Torque	T _{pk}	Nm	1.19	1.19
Torque Constant ±10%	K _t	Nm/Arms	0.071	0.123
Back EMF Constant ±10%	K _e	Vpeak/rpm	0.006	0.011
Motor Constant @25°C	K _m	Nm/Sqrt(W)	0.058	0.068
Resistance (L-L) @25°C ±10%	R ₂₅	Ω	1.01	2.21
Inductance (L-L) ±20%	L	mH	0.144	0.316
Electrical Time Constant	τ _e	ms	0.14	0.14
Continuous Current @100°C	I _{cn}	Arms	4.8	2.8
Peak Current	I _{pk}	Arms	16.8	9.7
Continuous Power Dissipation @100°C	P _{cn}	W	44.8	32.7
Max. Coil Temperature	t _{max}	°C	100	100
Thermal Dissipation Constant	K _{thn}	W/°C	0.597	0.436
Max. Bus Voltage	U _{bus}	Vdc	48.0	48.0
Pole Number	2P	-	8	8
Rec. Max. Speed @48 VDC (Digital / SINCOS)	Ω _{max}	rpm	1200	1200
Mechanical Parameters				
Overall Mass	m _n	kg	0.80	0.80
Rotor Inertia	J _r	kg·m ²	3.944E-05	3.944E-05
Axial Runout	-	μm	12	12
Radial Runout	-	μm	10	10
Max. Axial Load (Upright Mounting)	-	N	50	50
Max. Axial Load (Inverted / Wall Mounting)	-	N	5	5
Max. Moment Load (Upright Mounting)	-	Nm	0.3	0.3
Max. Moment Load (Inverted / Wall Mounting)	-	Nm	0.05	0.05
Encoder Parameters				
ABI Optical Incremental Encoder (SIN/COS)	-	lines / rev	1620	1620
ABI Optical Incremental Encoder (80x)	-	counts / rev	129600	129600
ABI Optical Incremental Encoder (160x)	-	counts / rev	259200	259200
ABI Optical Incremental Encoder (400x)	-	counts / rev	648000	648000
Accuracy after Error Mapping	-	arc sec	+/-6	+/-6
Repeatability	-	arc sec	+/-3	+/-3
Other Information				
Insulation Class	Class B (130°C)			
Protection Grade	IP40			
Compliance with Global Standards	RoHS, CE			
Ambient Temperature	Operation	0°C to 40°C (non-freezing)		
	Storage	-15°C to 70°C (non-freezing)		
Ambient Humidity	Operation	10%RH to 80%RH (non-condensing)		
	Storage	10%RH to 90%RH (non-condensing)		
Recommended Ambience	Indoor (no direct sunlight); No corrosive gas, inflammable gas, oil mist or dust.			

- Measurement is taken at ambient temperature 25°C. Value depends on the thermal environment.
 - Resistance is measured by DC current with standard 3 m cable.
 - Inductance is measured by current frequency of 1 kHz.
 - The value is based on ABI optical SIN/COS encoder (4096x interpolation) under max. bus voltage.
 - The runout value in parenthesis is optional.
 - Please refer to the illustration for different mountings.
 - Based on ABI optical SIN/COS encoder (4096x interpolation) with standard runout.
- The contents of datasheet are subjected to change without prior notice.

Dimension

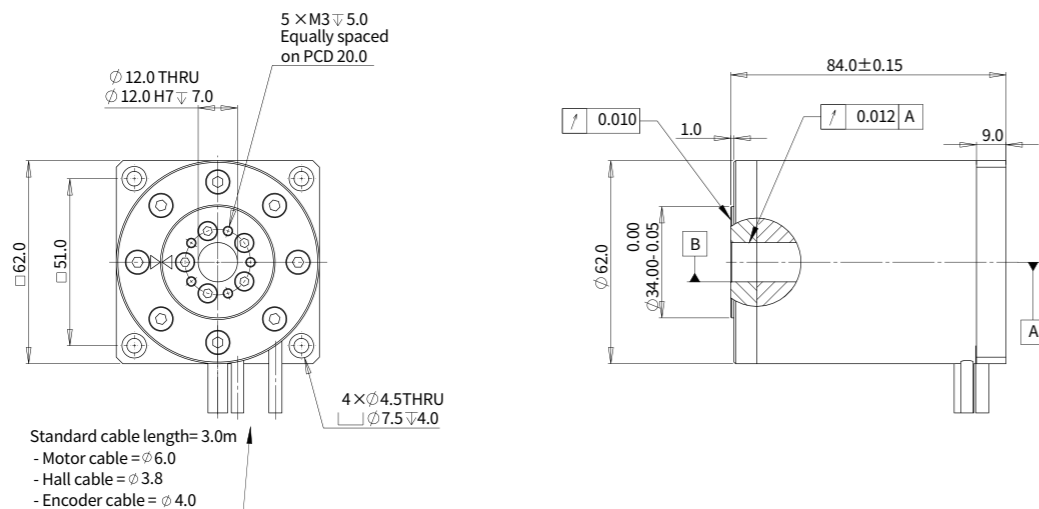

Torque-Speed Curve

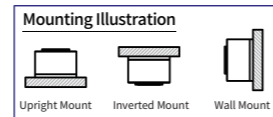
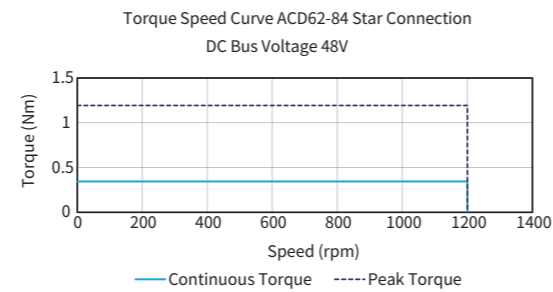
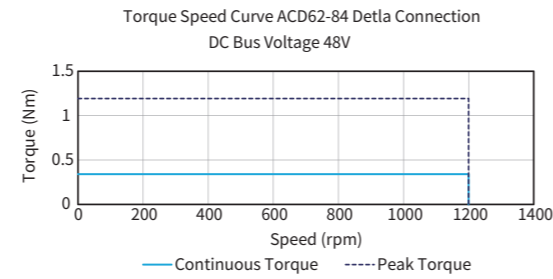

ACD120-80

ACD120-80				
Performance Parameters	Symbol	Unit	D	Y
Continuous Torque @100°C	T _{cn}	Nm	1.85	1.85
Peak Torque	T _{pk}	Nm	6.46	6.46
Torque Constant ±10%	K _t	Nm/Arms	0.36	0.63
Back EMF Constant ±10%	K _e	Vpeak/rpm	0.031	0.054
Motor Constant @25°C	K _m	Nm/Sqrt(W)	0.220	0.238
Resistance (L-L) @25°C ±10%	R ₂₅	Ω	1.80	4.64
Inductance (L-L) ±20%	L	mH	0.628	1.900
Electrical Time Constant	τ _e	ms	0.35	0.41
Continuous Current @100°C	I _{cn}	Arms	5.1	2.9
Peak Current	I _{pk}	Arms	17.9	10.3
Continuous Power Dissipation @100°C	P _{cn}	W	90.4	77.7
Max. Coil Temperature	t _{max}	°C	100	100
Thermal Dissipation Constant	K _{thn}	W/°C	1.205	1.036
Max. Bus Voltage	U _{bus}	Vdc	330.0	330.0
Pole Number	2P	-	12	12
Rec. Max. Speed @230 VAC (Digital / SINCOS)	Ω _{max}	rpm	952	952
Mechanical Parameters				
Overall Mass	m _n	kg	3.2	3.2
Rotor Inertia	J _r	kg·m ²	1.08E-03	1.08E-03
Axial Runout	-	μm	15	15
Radial Runout	-	μm	10	10
Max. Axial Load (Upright Mounting)	-	N	150	150
Max. Axial Load (Inverted / Wall Mounting)	-	N	15	15
Max. Moment Load (Upright Mounting)	-	Nm	10	10
Max. Moment Load (Inverted / Wall Mounting)	-	Nm	1.0	1.0
Encoder Parameters				
ABI Optical Incremental Encoder (SIN/COS)	-	lines / rev	2868	2868
ABI Optical Incremental Encoder (80x)	-	counts / rev	229440	229440
ABI Optical Incremental Encoder (160x)	-	counts / rev	458880	458880
ABI Optical Incremental Encoder (400x)	-	counts / rev	1147200	1147200
Accuracy after Error Mapping	-	arc sec	+/-6	+/-6
Repeatability	-	arc sec	+/-3	+/-3
Other Information				
Insulation Class	Class B (130°C)			
Protection Grade	IP40			
Compliance with Global Standards	RoHS, CE			
Ambient Temperature	Operation	0°C to 40°C (non-freezing)		
	Storage	-15°C to 70°C (non-freezing)		
Ambient Humidity	Operation	10%RH to 80%RH (non-condensing)		
	Storage	10%RH to 90%RH (non-condensing)		
Recommended Ambience	Indoor (no direct sunlight); No corrosive gas, inflammable gas, oil mist or dust.			

- Measurement is taken at ambient temperature 25°C. Value depends on the thermal environment.
 - Resistance is measured by DC current with standard 3 m cable.
 - Inductance is measured by current frequency of 1 kHz.
 - The value is based on ABI optical SIN/COS encoder (4096x interpolation) under max. bus voltage.
 - The runout value in parenthesis is optional.
 - Please refer to the illustration for different mountings.
 - Based on ABI optical SIN/COS encoder (4096x interpolation) with standard runout.
- The contents of datasheet are subjected to change without prior notice.

Dimension

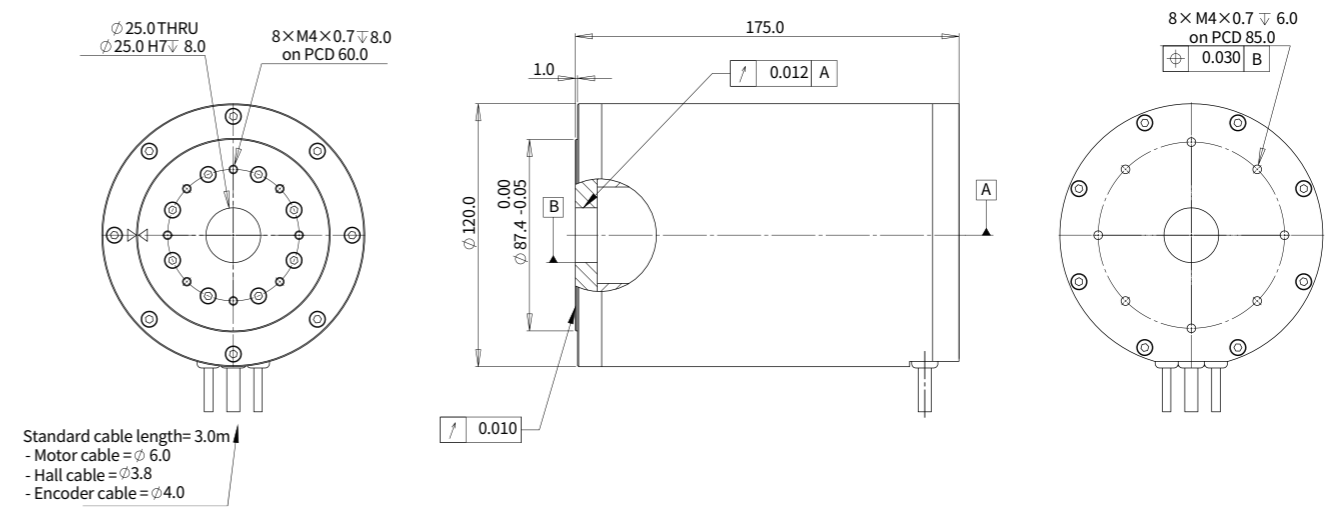

Torque-Speed Curve

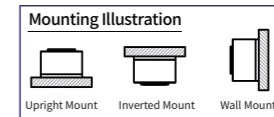
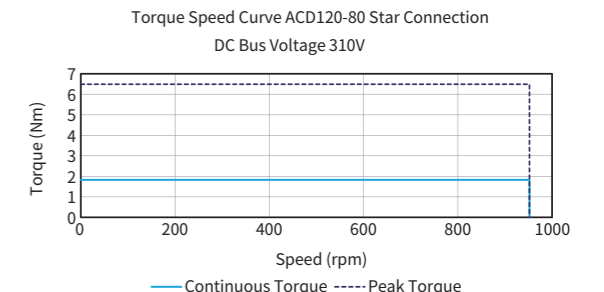
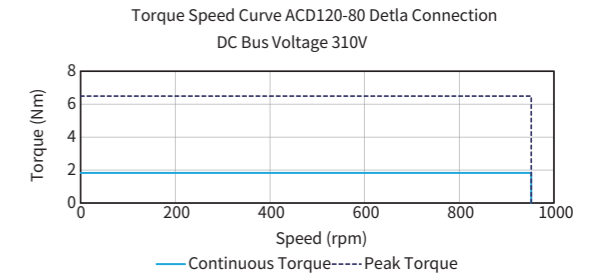

Introduction Sizing Guide Frequently Asked Questions Linear Motors Voice Coil Motors Direct Drive Rotary Motors Motion Control of Gantry Stages

Akribis systems

Introduction Sizing Guide Frequently Asked Questions Linear Motors Voice Coil Motors Direct Drive Rotary Motors Motion Control of Gantry Stages

Akribis systems

ACD120-175

ACD120-175				
Performance Parameters				
Continuous Torque @100°C	T _{cn}	Nm	9.22	9.22
Peak Torque	T _{pk}	Nm	32.25	32.25
Torque Constant ±10%	K _t	Nm/Arms	1.81	3.13
Back EMF Constant ±10%	K _e	Vpeak/rpm	0.154	0.268
Motor Constant @25°C	K _m	Nm/Sqrt(W)	0.736	0.736
Resistance (L-L) @25°C ±10%	R ₂₅	Ω	4.02	12.07
Inductance (L-L) ±20%	L	mH	1.873	5.619
Electrical Time Constant	τ _e	ms	0.47	0.47
Continuous Current @100°C	I _{cn}	Arms	5.1	2.9
Peak Current	I _{pk}	Arms	17.9	10.3
Continuous Power Dissipation @100°C	P _{cn}	W	202.4	202.1
Max. Coil Temperature	t _{max}	°C	100	100
Thermal Dissipation Constant	K _{thn}	W/°C	2.698	2.695
Max. Bus Voltage	U _{bus}	Vdc	330.0	330.0
Pole Number	2P	-	12	12
Rec. Max. Speed @230 VAC (Digital / SINCOS)	Ω _{max}	rpm	220	220
Mechanical Parameters				
Overall Mass	m _n	kg	7.0	7.0
Rotor Inertia	J _r	kg·m ²	3.21E-03	3.21E-03
Axial Runout	-	μm	15	15
Radial Runout	-	μm	10	10
Max. Axial Load (Upright Mounting)	-	N	150	150
Max. Axial Load (Inverted / Wall Mounting)	-	N	15	15
Max. Moment Load (Upright Mounting)	-	Nm	10	10
Max. Moment Load (Inverted / Wall Mounting)	-	Nm	1.0	1.0
Encoder Parameters				
ABI Optical Incremental Encoder (SIN/COS)	-	lines / rev	2868	2868
ABI Optical Incremental Encoder (80x)	-	counts / rev	229440	229440
ABI Optical Incremental Encoder (160x)	-	counts / rev	458880	458880
ABI Optical Incremental Encoder (400x)	-	counts / rev	1147200	1147200
Accuracy after Error Mapping	-	arc sec	+/-6	+/-6
Repeatability	-	arc sec	+/-3	+/-3
Other Information				
Insulation Class	Class B (130°C)			
Protection Grade	IP40			
Compliance with Global Standards	RoHS, CE			
Ambient Temperature	Operation	0°C to 40°C (non-freezing)		
	Storage	-15°C to 70°C (non-freezing)		
Ambient Humidity	Operation	10%RH to 80%RH (non-condensing)		
	Storage	10%RH to 90%RH (non-condensing)		
Recommended Ambience	Indoor (no direct sunlight); No corrosive gas, inflammable gas, oil mist or dust.			

- Measurement is taken at ambient temperature 25°C. Value depends on the thermal environment.
 - Resistance is measured by DC current with standard 3 m cable.
 - Inductance is measured by current frequency of 1 kHz.
 - The value is based on ABI optical SIN/COS encoder (4096x interpolation) under max. bus voltage.
 - The runout value in parenthesis is optional.
 - Please refer to the illustration for different mountings.
 - Based on ABI optical SIN/COS encoder (4096x interpolation) with standard runout.
- The contents of datasheet are subjected to change without prior notice.

Dimension

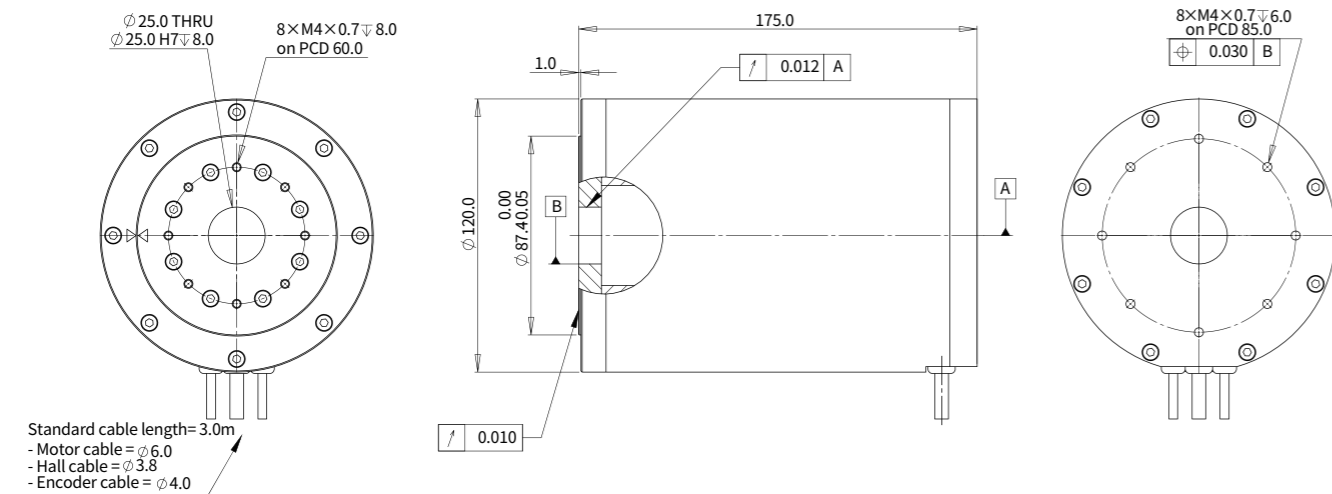

Torque-Speed Curve

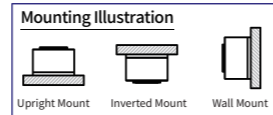
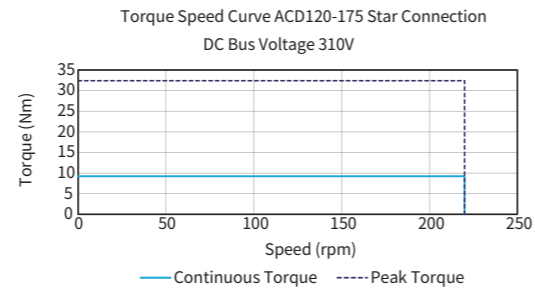
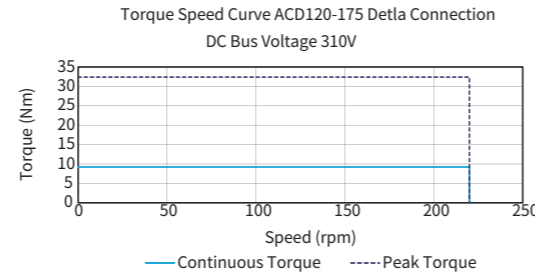

Part Numbering

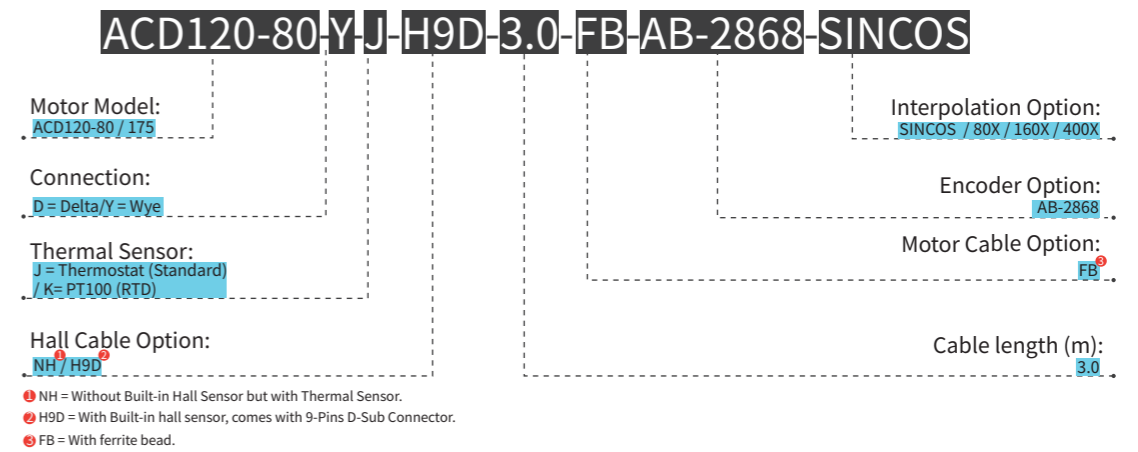
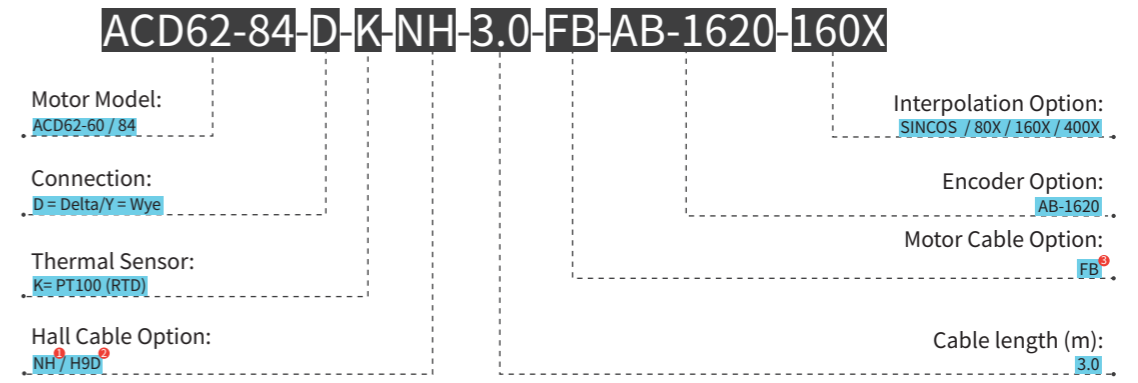

Motor Cable Connection

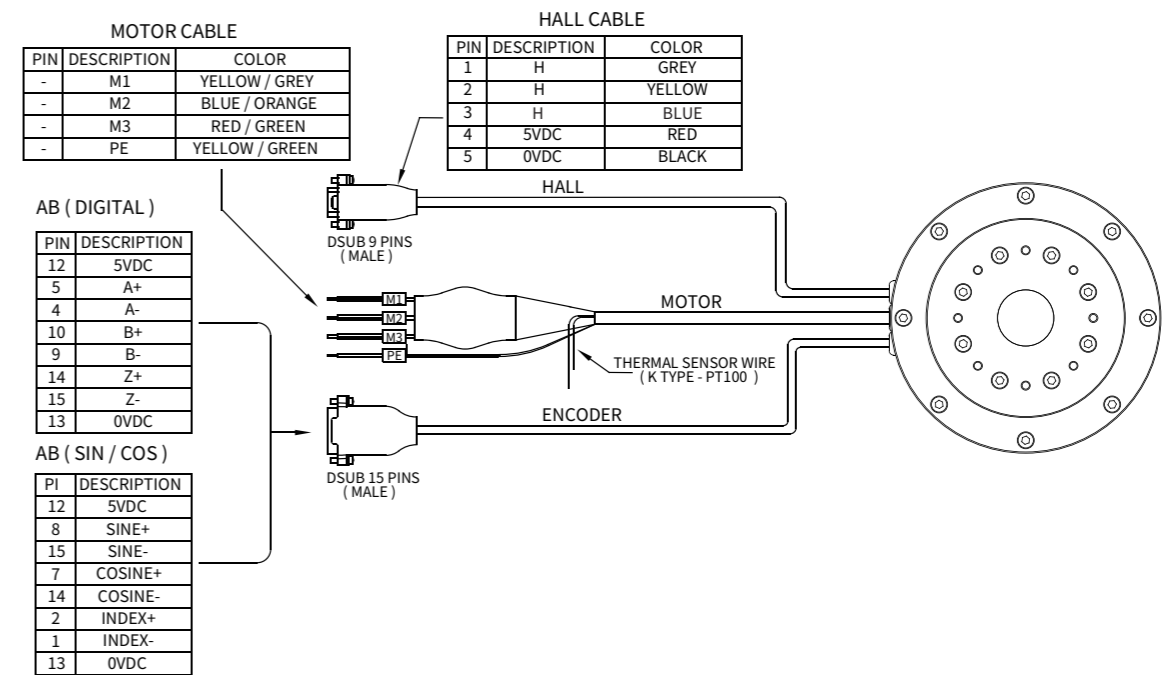

Introduction Sizing Guide Frequently Asked Questions Linear Motors Voice Coil Motors Direct Drive Rotary Motors Motion Control of Gantry Stages Akribis systems

Introduction Sizing Guide Frequently Asked Questions Linear Motors Voice Coil Motors Direct Drive Rotary Motors Motion Control of Gantry Stages Akribis systems

ACD62-P-10

ACD62-P-10				
Performance Parameters	Symbol	Unit	D	Y
Continuous Torque @100°C	T _{cn}	Nm	0.115	0.115
Peak Torque	T _{pk}	Nm	0.40	0.40
Torque Constant ±10%	K _t	Nm/Arms	0.024	0.042
Back EMF Constant ±10%	K _e	V _{peak} /rpm	0.002	0.004
Motor Constant @25°C	K _m	Nm/Sqrt(W)	0.023	0.028
Resistance (L-L) @25°C ±10%	R ₂₅	Ω	0.73	1.51
Inductance (L-L) ±20%	L	mH	0.073	0.195
Electrical Time Constant	τ _e	ms	0.10	0.13
Continuous Current @100°C	I _{cn}	Arms	4.8	2.8
Peak Current	I _{pk}	Arms	16.8	9.7
Continuous Power Dissipation @100°C	P _{cn}	W	32.6	22.4
Max. Coil Temperature	t _{max}	°C	100	100
Thermal Dissipation Constant	K _{thn}	W/°C	0.435	0.298
Max. Bus Voltage	U _{bus}	V _{dc}	48.0	48.0
Pole Number	2p	-	8	8

Mechanical Parameters				
Overall Mass	m _n	kg	0.5	0.5
Rotor Inertia	J _r	kg·m ²	9.714E-06	9.714E-06

Other Information				
Insulation Class	Class B (130°C)			
Protection Grade	IP00			
Compliance with Global Standards	RoHS, CE			
Ambient Temperature	Operation	0°C to 40°C (non-freezing)		
	Storage	-15°C to 70°C (non-freezing)		
Ambient Humidity	Operation	10%RH to 80%RH (non-condensing)		
	Storage	10%RH to 90%RH (non-condensing)		
Recommended Ambience	Indoor (no direct sunlight); No corrosive gas, inflammable gas, oil mist or dust.			

- Measurement is taken at ambient temperature 25°C. Value depends on the thermal environment.
 - Resistance is measured by DC current with standard 3 m cable.
 - Inductance is measured by current frequency of 1 kHz.
- The contents of datasheet are subjected to change without prior notice.

Dimension

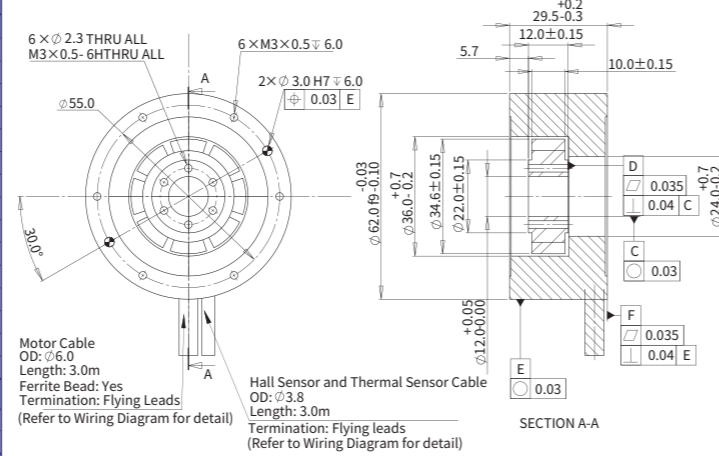

- Note:
- User to ensure the concentricity of stator and rotor to be within 0.15mm when mounted;
 - User to ensure flatness of mounting surface within 0.015/300mm;
 - User to ensure perpendicularity of rotor inner bore relative to datum E within 0.1mm when mounted;
 - The cable diameter tolerance +0.3, and cable length tolerance +60.0

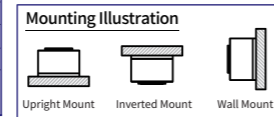

ACD120-P-20

ACD120-P-20				
Performance Parameters	Symbol	Unit	D	Y
Continuous Torque @100°C	T _{cn}	Nm	1.85	1.85
Peak Torque	T _{pk}	Nm	6.46	6.46
Torque Constant ±10%	K _t	Nm/Arms	0.36	0.63
Back EMF Constant ±10%	K _e	V _{peak} /rpm	0.031	0.054
Motor Constant @25°C	K _m	Nm/Sqrt(W)	0.220	0.238
Resistance (L-L) @25°C ±10%	R ₂₅	Ω	1.80	4.64
Inductance (L-L) ±20%	L	mH	0.628	1.900
Electrical Time Constant	τ _e	ms	0.35	0.41
Continuous Current @100°C	I _{cn}	Arms	5.1	2.9
Peak Current	I _{pk}	Arms	17.9	10.3
Continuous Power Dissipation @100°C	P _{cn}	W	90.4	77.7
Max. Coil Temperature	t _{max}	°C	100	100
Thermal Dissipation Constant	K _{thn}	W/°C	1.205	1.036
Max. Bus Voltage	U _{bus}	V _{dc}	330.0	330.0
Pole Number	2p	-	12	12

Mechanical Parameters				
Overall Mass	m _n	kg	3.2	3.2
Rotor Inertia	J _r	kg·m ²	5.950E-04	5.950E-04

Other Information				
Insulation Class	Class B (130°C)			
Protection Grade	IP00			
Compliance with Global Standards	RoHS, CE			
Ambient Temperature	Operation	0°C to 40°C (non-freezing)		
	Storage	-15°C to 70°C (non-freezing)		
Ambient Humidity	Operation	10%RH to 80%RH (non-condensing)		
	Storage	10%RH to 90%RH (non-condensing)		
Recommended Ambience	Indoor (no direct sunlight); No corrosive gas, inflammable gas, oil mist or dust.			

- Measurement is taken at ambient temperature 25°C. Value depends on the thermal environment.
 - Resistance is measured by DC current with standard 3 m cable.
 - Inductance is measured by current frequency of 1 kHz.
- The contents of datasheet are subjected to change without prior notice.

Dimension

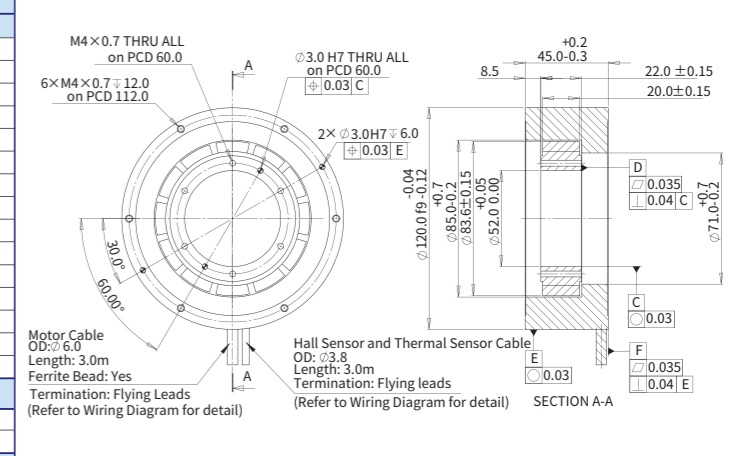

- Note:
- User to ensure the concentricity of stator and rotor to be within 0.15mm when mounted;
 - User to ensure flatness of mounting surface within 0.015/300mm;
 - User to ensure perpendicularity of rotor inner bore relative to datum E within 0.1mm when mounted;
 - The cable diameter tolerance +0.3, and cable length tolerance +60.0

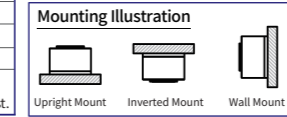

ACD62-P-30

ACD62-P-30				
Performance Parameters	Symbol	Unit	D	Y
Continuous Torque @100°C	T _{cn}	Nm	0.341	0.341
Peak Torque	T _{pk}	Nm	1.19	1.19
Torque Constant ±10%	K _t	Nm/Arms	0.071	0.123
Back EMF Constant ±10%	K _e	V _{peak} /rpm	0.006	0.011
Motor Constant @25°C	K _m	Nm/Sqrt(W)	0.058	0.068
Resistance (L-L) @25°C ±10%	R ₂₅	Ω	1.01	2.21
Inductance (L-L) ±20%	L	mH	0.144	0.316
Electrical Time Constant	τ _e	ms	0.14	0.14
Continuous Current @100°C	I _{cn}	Arms	4.8	2.8
Peak Current	I _{pk}	Arms	16.8	9.7
Continuous Power Dissipation @100°C	P _{cn}	W	44.8	32.7
Max. Coil Temperature	t _{max}	°C	100	100
Thermal Dissipation Constant	K _{thn}	W/°C	0.597	0.436
Max. Bus Voltage	U _{bus}	V _{dc}	48.0	48.0
Pole Number	2p	-	8	8

Mechanical Parameters				
Overall Mass	m _n	kg	0.8	0.8
Rotor Inertia	J _r	kg·m ²	2.883E-05	2.883E-05

Other Information				
Insulation Class	Class B (130°C)			
Protection Grade	IP00			
Compliance with Global Standards	RoHS, CE			
Ambient Temperature	Operation	0°C to 40°C (non-freezing)		
	Storage	-15°C to 70°C (non-freezing)		
Ambient Humidity	Operation	10%RH to 80%RH (non-condensing)		
	Storage	10%RH to 90%RH (non-condensing)		
Recommended Ambience	Indoor (no direct sunlight); No corrosive gas, inflammable gas, oil mist or dust.			

- Measurement is taken at ambient temperature 25°C. Value depends on the thermal environment.
 - Resistance is measured by DC current with standard 3 m cable.
 - Inductance is measured by current frequency of 1 kHz.
- The contents of datasheet are subjected to change without prior notice.

Dimension

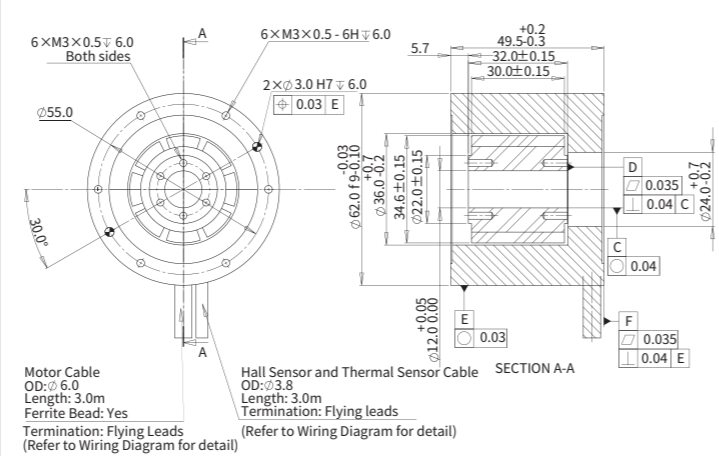

- Note:
- User to ensure the concentricity of stator and rotor to be within 0.15mm when mounted;
 - User to ensure flatness of mounting surface within 0.015/300mm;
 - User to ensure perpendicularity of rotor inner bore relative to datum E within 0.1mm when mounted;
 - The cable diameter tolerance +0.3, and cable length tolerance +60.0

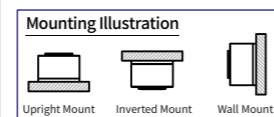

Introduction Sizing Guide Frequently Asked Questions Linear Motors Voice Coil Motors Direct Drive Rotary Motors Motion Control of Gantry Stages Akribis systems

Introduction Sizing Guide Frequently Asked Questions Linear Motors Voice Coil Motors Direct Drive Rotary Motors Motion Control of Gantry Stages Akribis systems

Part Numbering

ACD62-P-10-D-K-NH-3.0-FB

Motor Model:

ACD62-P-10/ACD62-P-30

Connection:

D = Delta/Y = Wye

Thermal Sensor:

K = PT100 (RTD)

Motor Cable Option:

FB

Cable length (m):

3.0

Hall Cable Option:

HF/NH

ACD120-P-20-Y-J-HF-3.0-FB

Motor Model:

ACD120-P-20

Connection:

D = Delta/Y = Wye

Thermal Sensor:

J = Thermostat (Standard)

K = PT100 (RTD)

Motor Cable Option:

FB

Cable length (m):

3.0

Hall Cable Option:

HF/NH

- HF = With Built-in hall sensor & hall cable comes with flying leads.
- NH = Without Built-in Hall Sensor but with Thermal Sensor.
- FB = With ferrite bead.

Motor Cable Connection

