

# B3S & B3W ELECTRIC RODLESS ACTUATORS

**ENDURANCE TECHNOLOGY**<sup>SM</sup>

A Tolomatic Design Principle

**B3S SCREW-DRIVE**  
**B3W BELT-DRIVE**



**Motion Control Products Ltd**  
11-15 Francis Avenue, Bournemouth  
Dorset, UK, BH11 8NX  
Tel.: +44 (0)1202 599922  
[enquiries@motioncontrolproducts.com](mailto:enquiries@motioncontrolproducts.com)  
[www.motioncontrolproducts.com](http://www.motioncontrolproducts.com)

**LINEAR SOLUTIONS MADE EASY**

# Tolomatic B3S & B3W Electric Rodless Actuators

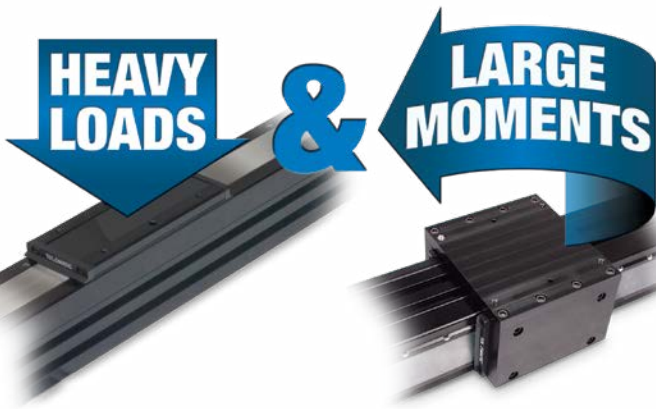

## The Power to Move Heavy Loads

The B3S and B3W electric rodless actuators have very large moment and load carrying capacities. The sealed recirculating ball bearing design makes it an excellent choice for challenging environments. For even higher capacity (loads up to 3,629 kg.) choose the Dual 180° Carrier and add an auxiliary carrier. Both actuators utilize a patented internal re-circulating ball bearing guidance system that provides extremely long life. These actuators are capable of carrying loads up to 3,629 kg [8,000 lbs].

## A COMPARISON OF SCREW DRIVE ACTUATORS

	TRS	B3S	MXE-S	MXE-P
<b>Features:</b>	Dual profile rail bearing actuator	High load and bending moment capacities	Basic guidance and support	High load and bending moment capacities
<b>Load up to: (with options)</b>	6.0 kN [1,356 lbf]	35.6 kN [8,000 lbf]	4.6 kN [1,040 lbf]	11.5 kN [2,584 lbf]
<b>Thrust up to:</b>	2.5 kN [562 lbf]	12 kN [2,700 lbf]	19.1 kN [4,300 lbf]	19.1 kN [4,300 lbf]
<b>Speed up to:</b>	0.91 m/sec [36 in/sec]	1.5 m/sec [60 in/sec]	1.5 m/sec [60 in/sec]	1.5 m/sec [60 in/sec]
<b>Stroke Length up to:</b>	1.1 m [43 in]	4.5 m [179 in]	4.5 m [178 in]	4.5m [178 in]
<b>Screw/Nut Type</b>	Solid & Ball	Solid & Ball	Solid & Ball	Solid & Ball
<a href="http://www.tolomatic.com">www.tolomatic.com</a> for complete information, search by literature number:				
<b>Literature Number:</b>	3600-4222	3600-4176	8300-4000	8300-4000

(Not all models deliver ALL maximum values listed, i.e.: Maximum thrust may not be available with maximum speed)

## A COMPARISON OF BELT DRIVE ACTUATORS

	B3W	MXB-U	MXB-S	MXB-P
<b>Features:</b>	High load and bending moment capacities	Basic thrust, requires external guidance and support	Medium load and bending moment capacities	High load and bending moment capacities
<b>Load up to: (with options)</b>	35.6 kN [8,000 lbf]	NA	4.6 kN [1,040 lbf]	11.5 kN [2,584 lbf]
<b>Thrust up to:</b>	1.4 kN [325 lbf]	1.9 kN [418 lbf]	1.9 kN [418 lbf]	1.9 kN [418 lbf]
<b>Speed up to:</b>	5.1 m/sec [200 in/sec]	5.1 m/sec [200 in sec]	2.5 m/sec [100 in sec]	3.9 m/sec [150 in/sec]
<b>Stroke Length up to:</b>	14.6 m [574 in]	10.5 m [414 in]	10.5 m [414 in]	10.5 m [414 in]
<a href="http://www.tolomatic.com">www.tolomatic.com</a> for complete information, search by literature number:				
<b>Literature Number:</b>	3600-4176	8500-4000	8500-4000	8500-4000

(Not all models deliver ALL maximum values listed, i.e.: Maximum thrust may not be available with maximum speed)

# B3S & B3W Applications

## Applying, Dispensing

- Spraying
- Cutting
- Slitting
- Test Fixtures
- Inspection

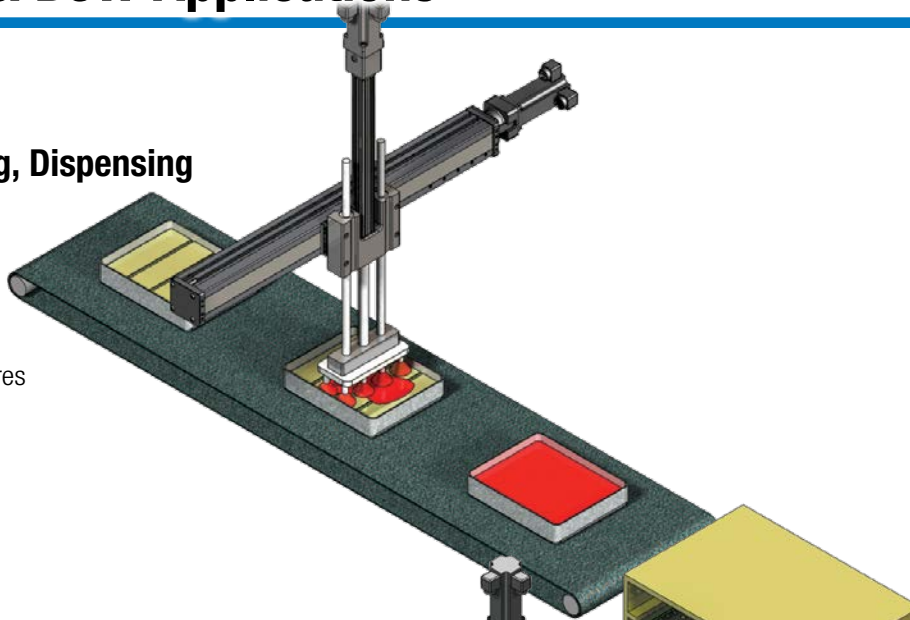

## Storage & Retrieval

- Parts Transfer
- Pick & Place
- Stacking
- Sorting

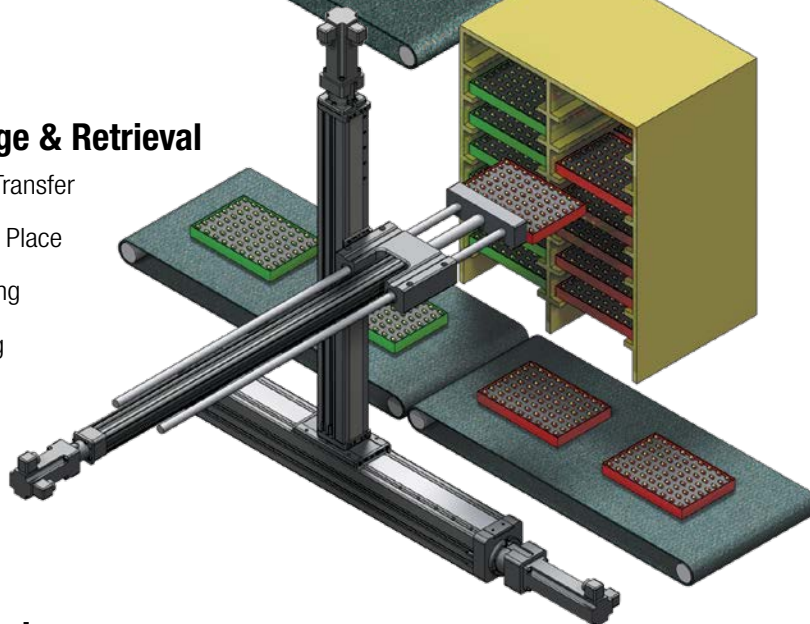

## X-Y Gantry/Multi Axis

- Laser marking
- Material cutting
- Adhesive dispensing

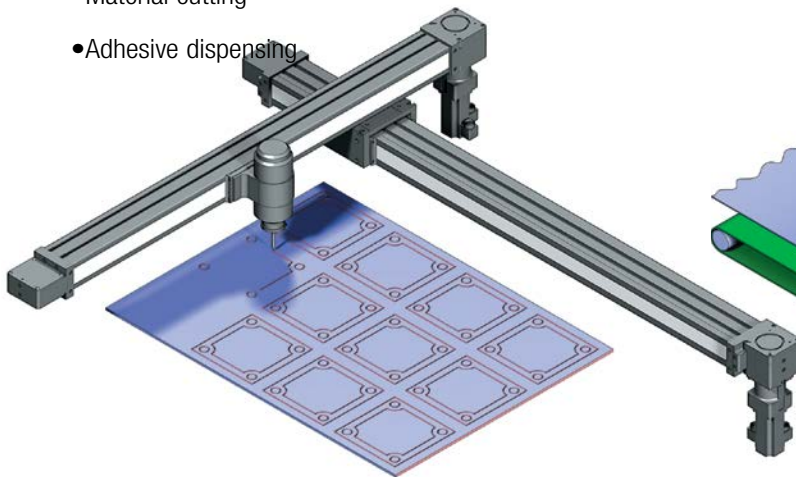

## High Speed Flying Cut Off

- Test stations
- Product handling
- Camera positioning

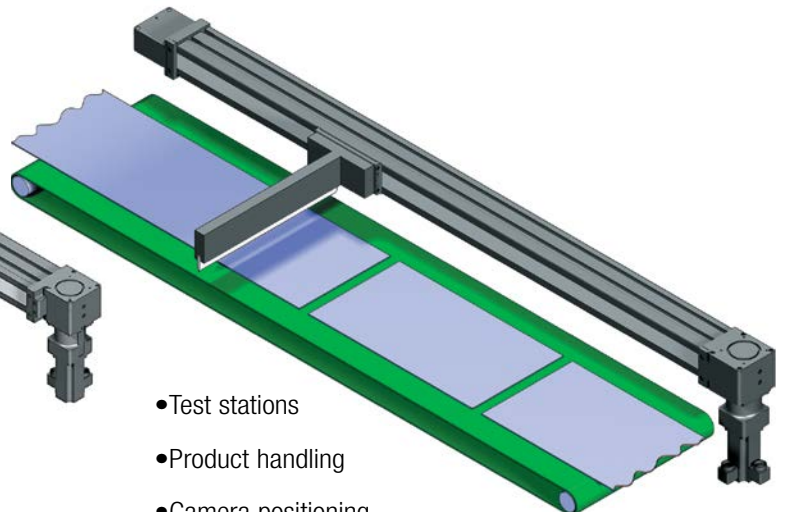

## CONTENTS

Rodless Comparisons.....	B3_2
B3S & B3W Applications.....	B3_3
B3S Features.....	B3_4
B3W Features.....	B3_6
B3S & B3W Performance.....	B3_8
B3S Specifications.....	B3_9
Critical Speed (Acme).....	B3_13
PV Limits (Acme).....	B3_14
Critical Speed (Ball).....	B3_15
Ball Screw Life.....	B3_16
B3S Dimensions.....	B3_17-24
B3W Performance.....	B3_25
B3W Specifications.....	B3_27
B3W Dimensions.....	B3_28-34
Switches.....	B3_35
Application Data	
Worksheet.....	B3_37
Selection Guidelines.....	B3_38
B3S Ordering.....	B3_39
B3W Ordering.....	B3_40
Other Tolomatic	
Products.....	B3_41

# B3S RODLESS SCREW DRIVE ACTUATOR

## ENDURANCE TECHNOLOGY<sup>SM</sup>

Endurance Technology features are designed for maximum durability to provide extended service life.

A Tolomatic Design Principle

The B3S rodless screw-drive electric actuator is designed for carrying moderate to heavy loads with large bending moment capacity. The B3S utilizes an integral recirculating ball bearing guidance system that provides durable performance and extremely long life. Choose from multiple screw technologies for thrust up to 12 kN [2,700 lbf]. Built-to-order in stroke lengths up to 10.6 m [416 inches].

### LOAD-BEARING CARRIER DESIGN

Load and moments are transmitted directly to the actuator body

### FORMED END CAP WIPERS

Prevent contaminants from entering the sealing band area to protect internal components

### MULTIPLE SCREW TECHNOLOGIES

#### YOU CAN CHOOSE:

- Solid nuts of engineered resins offer quiet performance at the lowest cost; anti-backlash available
- Ball nuts offer positioning accuracy and repeatability with longer life; low-backlash available

### STAINLESS STEEL SEALING BAND

- Prevents contaminants from entering the screw and nut area for extended performance
- Fatigue resistant stainless steel bands are specifically made to offer long life and will not elongate
- Provides IP44 protection for bearings and screw nut

### INTERNAL BUMPERS

Bumpers protect the screw and nut assembly from damage at end of stroke

B3S

B3W

# Tolomatic™... MAXIMUM DURABILITY

EXCELLENCE IN MOTION

## SCREW SUPPORT BEARINGS

Unique high thrust bearing assembly design eliminates runout and isolates the linear forces from the drive shaft

## YOUR MOTOR HERE

### YOU CAN CHOOSE:

- Specify the device to be installed and actuator ships with proper mounting hardware
- Specify and ship your device to Tolomatic for factory installation
- Motor or gearbox supplied and installed by Tolomatic

## MOTOR ORIENTATION

### YOU CAN CHOOSE:

- Inline option directly couples the driving shaft and is typically a one-piece housing construction for optimum alignment and support of the motor
- Reverse-parallel option minimizes the overall length and offers a belt reduction drive with a 1:1 or 2:1 ratio

## LIGHTWEIGHT ALUMINUM DESIGN

- Black anodized extrusion design is optimized for rigidity and strength
- External switch channels on both sides allow easy placement and adjustment of position indicating switches

## RECIRCULATING BALL BEARING SYSTEM



- Unique design incorporates hardened steel raceways integral to the aluminum extrusion
- Bearing surfaces are adjusted at the factory for optimum preload and smooth performance
- Recirculating ball bearing system provides guidance, high efficiency and durability

## OPTIONS

### CARRIER OPTIONS

- **AUXILIARY CARRIER** doubles the load capacity and increases pitch and yaw bending moment capacities
- **DUAL 180° CARRIER** doubles the load capacity, increases roll and yaw bending moment capacities and offers a wide mounting platform

### MOUNTING OPTIONS

- **SURFACE MOUNT** two t-slots are integral on the entire underside of the actuator body for direct mounting
- **TUBE SUPPORTS** provide intermediate support of the actuator body throughout long stroke lengths
- **MOUNTING PLATES** provide intermediate support of the actuator body throughout long stroke lengths

### METRIC OPTION

Provides metric tapped holes for mounting of load to carrier and of actuator to mating surfaces

### SWITCHES

Styles include: reed, hall-effect or triac. Select either 5 m potted cable with flying leads or 150 mm to quick-disconnect coupler with mating 5 m cable

# B3W RODLESS BELT-DRIVE ACTUATOR

## ENDURANCE TECHNOLOGY<sup>SM</sup>

Endurance Technology features are designed for maximum durability to provide extended service life.

A Tolomatic Design Principle

The B3W rodless belt-drive electric actuator is designed for carrying moderate to heavy loads at moderate to high speeds with large bending moment capacity. The B3W utilizes an integral recirculating ball bearing guidance system that provides durable performance and extremely long life. The B3W belt-driven actuator features speeds up to 5.1 m/sec [200 in/sec]. Built-to-order in stroke lengths up to 5.3 m [207 inches].

### YOUR MOTOR HERE

#### YOU CAN CHOOSE:

- Specify the device to be installed and actuator ships with proper mounting hardware
- Specify and ship your device to Tolomatic for factory installation
- Motor or gearbox supplied and installed by Tolomatic

### STAINLESS STEEL SEALING BAND

- Prevents contaminants from entering the screw and nut area for extended performance
- Fatigue resistant stainless steel bands are specifically made to offer long life and will not elongate
- Provides IP44 protection for bearings and screw nut

### MOTOR ORIENTATION

#### YOU CAN CHOOSE:

- Direct drive option directly couples the driving shaft and is typically a one-piece housing construction for optimum alignment and support of the motor
- Reduction drive option minimizes the overall length and offers a belt reduction drive with a 1:1 or 2:1 ratio

### LIGHTWEIGHT ALUMINUM DESIGN

- Black anodized extrusion design is optimized for rigidity and strength
- External switch channels on both sides allow easy placement and adjustment of position indicating switches

### OVERSIZED PULLEY BEARINGS

Drive shaft assembly incorporates sealed ball bearings for complete support of the increased belt tension at high speeds

### INTERNAL BUMPERS

Bumpers protect the screw and nut assembly from damage at end of stroke

B3S

B3W

## RECIRCULATING BALL BEARING SYSTEM



- Unique design incorporates hardened steel raceways integral to the aluminum extrusion
- Bearing surfaces are adjusted at the factory for optimum preload and smooth performance
- Recirculating ball bearing system provides guidance, high efficiency and durability

## FORMED END CAP WIPERS

Prevent contaminants from entering the sealing band area to protect internal components

## BELT TENSIONING SYSTEM

- Full access to the idle pulley allows ease of adjustment for alignment and tensioning
- Dual adjustment screws and field tensioning kit provide simple maintenance

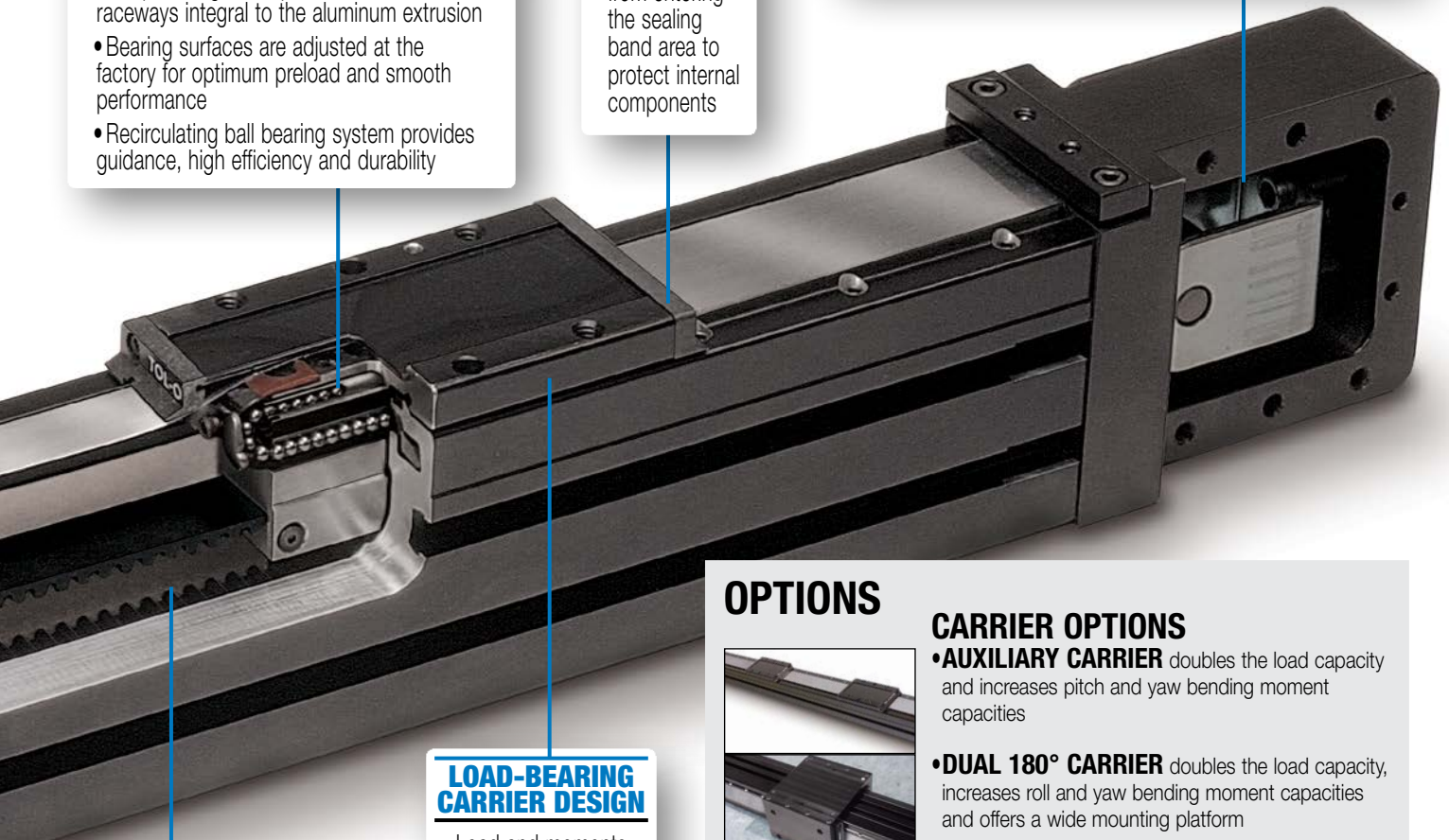

## LOAD-BEARING CARRIER DESIGN

Load and moments are transmitted directly to the actuator body

## MULTIPLE BELT TECHNOLOGIES

### YOU CAN CHOOSE:

- Polyurethane steel-cord reinforced HTD style belt (standard)
- Polyurethane Kevlar reinforced HTD style belt

## OPTIONS

### CARRIER OPTIONS

- **AUXILIARY CARRIER** doubles the load capacity and increases pitch and yaw bending moment capacities
- **DUAL 180° CARRIER** doubles the load capacity, increases roll and yaw bending moment capacities and offers a wide mounting platform

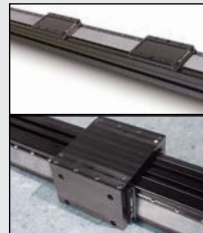

### MOUNTING OPTIONS

- **SURFACE MOUNT** two t-slots are integral on the entire underside of the actuator body for direct mounting
- **TUBE SUPPORTS** provide intermediate support of the actuator body throughout long stroke lengths
- **MOUNTING PLATES** provide intermediate support of the actuator body throughout long stroke lengths



### METRIC OPTION

Provides metric tapped holes for mounting of load to carrier and of actuator to mating surfaces

### SWITCHES

Styles include: reed, hall-effect or triac. Select either 5 m potted cable with flying leads or 150 mm to quick-disconnect coupler with mating 5 m cable



B3S

B3W

# B3S & B3W Electric Rodless Actuators

## SPECIFICATIONS both Screw & Belt Drive

sizeit.tolomatic.com for fast, accurate actuator selection

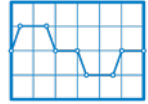

### DYNAMIC BENDING MOMENTS AND LOADS

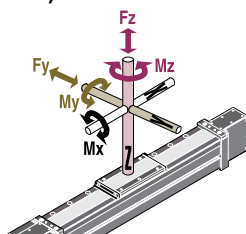
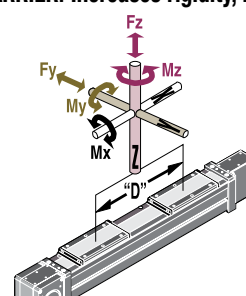
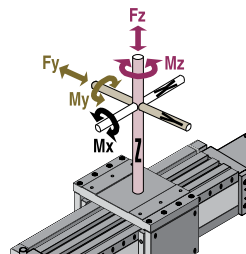
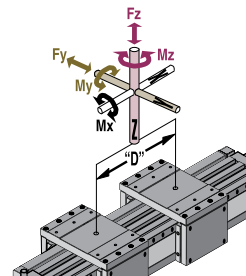
	Size	METRIC			U.S. CONVENTIONAL		
		10	15	20	10	15	20
<b>SINGLE (STANDARD) CARRIER</b>							
							
<b>Mx Moment (Roll)</b> (N-m : lb-in)		28.2	97	188	250	859	1,662
<b>My Moment (Pitch)</b> (N-m : lb-in)		30.4	117	166	269	1,033	1,472
<b>Mz Moment (Yaw)</b> (N-m : lb-in)		17.6	67	96	156	596	850
<b>Fy Load (Radial)</b> (N : lb)		1,517	3,737	5,155	341	840	1,159
<b>Fz Load (Lateral)</b> (N : lb)		2,629	6,468	8,932	591	1,454	2,008
<b>AUXILIARY CARRIER: Increases rigidity, load-carrying capacity and moments</b>							
							
<b>Mx Moment (Roll)</b> *(N-m : lb-in)		57	194	376	500	1,718	3,324
<b>My Moment (Pitch)</b> *(N-m : lb-in)		319	1,326	1,838	2,825	11,734	16,265
<b>Mz Moment (Yaw)</b> *(N-m : lb-in)		184	766	1,061	1,630	6,779	9,388
<b>Fy Load (Radial)</b> (N : lb)		3,034	7,473	10,311	682	1,680	2,318
<b>Fz Load (Lateral)</b> (N : lb)		5,258	12,935	17,864	1,182	2,908	4,016
<b>Minimum Dimension 'D'</b> (mm : in)		124	205	206	4.88	8.07	8.10
<b>DUAL 180° CARRIER: Allows 90° rotation of load, adds load bearing surface</b>							
							
<b>Mx Moment (Roll)</b> (N-m : lb-in)		74	279	512	657	2,468	4,527
<b>My Moment (Pitch)</b> (N-m : lb-in)		35.3	135	192	312	1,192	1,700
<b>Mz Moment (Yaw)</b> (N-m : lb-in)		61	233	333	538	2,066	2,944
<b>Fy Load (Radial)</b> (N : lb)		5,258	12,935	17,864	1,182	2,908	4,016
<b>Fz Load (Lateral)</b> (N : lb)		3,034	7,473	10,311	682	1,680	2,318
<b>AUXILIARY DUAL 180° CARRIER: Substantially increases moment and loads</b>							
							
<b>Mx Moment (Roll)</b> *(N-m : lb-in)		149	558	1,023	1,314	4,936	9,054
<b>My Moment (Pitch)</b> *(N-m : lb-in)		376	1,532	2,121	3,328	13,558	18,776
<b>Mz Moment (Yaw)</b> *(N-m : lb-in)		652	2,652	3,675	5,768	23,468	32,530
<b>Fy Load (Radial)</b> (N : lb)		10,516	25,871	35,728	2,364	5,816	8,032
<b>Fz Load (Lateral)</b> (N : lb)		6,067	14,946	20,622	1,364	3,360	4,636
<b>Minimum Dimension 'D'</b> (mm : in)		124	205	206	4.88	8.07	8.10



The Dual 180° carrier requires its own proprietary tube supports and foot mounts. See dimensional information. Breakaway torque will also increase when using the Auxiliary carrier or the Dual 180° carrier options. When ordering, determine working stroke and enter this value into the configuration string. Overall actuator length will automatically be calculated.

**Deflection Considerations:** In applications where substantial Mx or My moments come into play, deflection of the cylinder tube, carrier and supports must be considered. The deflection factors shown in the Load Deflection charts on the following page are based on cylinder mounted with tube supports at minimum recommended spacing. If more rigidity is desired, refer to the Auxiliary or Dual Carrier options.

\*Loads shown in table are at minimum "D" dimension, for ratings with longer "D" dimension see graphs on page B3\_10.

Life of the actuator will vary for each application depending on the combined loads, motion parameters and operating conditions. The load factor ( $L_f$ ) ratios for each application must not exceed a value of 1.5 (see formula at right). Exceeding a load factor of 1.5 will diminish the actuator's rated life.

$$L_f = \frac{M_x}{M_{x_{max}}} + \frac{M_y}{M_{y_{max}}} + \frac{M_z}{M_{z_{max}}} + \frac{F_y}{F_{y_{max}}} + \frac{F_z}{F_{z_{max}}} \leq 1.5$$

With combined loads,  $L_f$  must not exceed the value 1.5

# B3S & B3W Electric Rodless Actuators

## SPECIFICATIONS both Screw & Belt Drive

sizeit.tolomatic.com for fast, accurate actuator selection

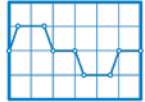

### LOAD DEFLECTION

#### DEFLECTION ABOUT X AXIS

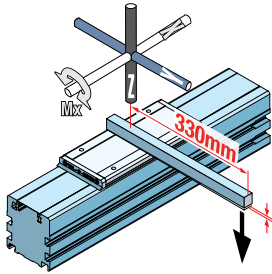

DEFLECTION TESTING WAS DONE UNDER THESE CRITERIA:

- 1.) Actuator was properly mounted with distance between supports within recommendations (see Support Recommendations below)
- 2.) Deflection was measured from center of carrier as shown (Mx = 330mm, My = 203mm)

#### DEFLECTION ABOUT Y AXIS

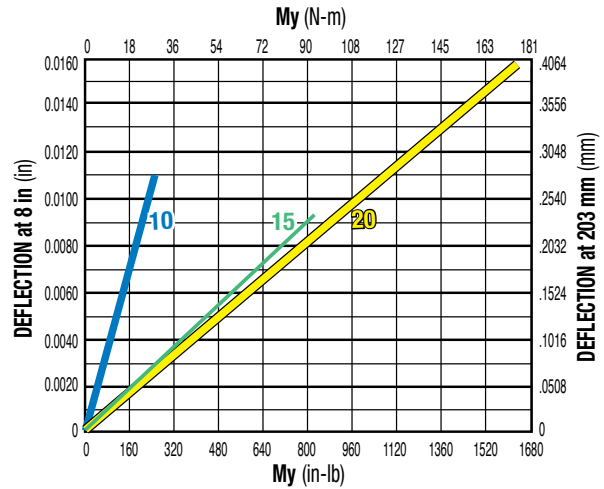
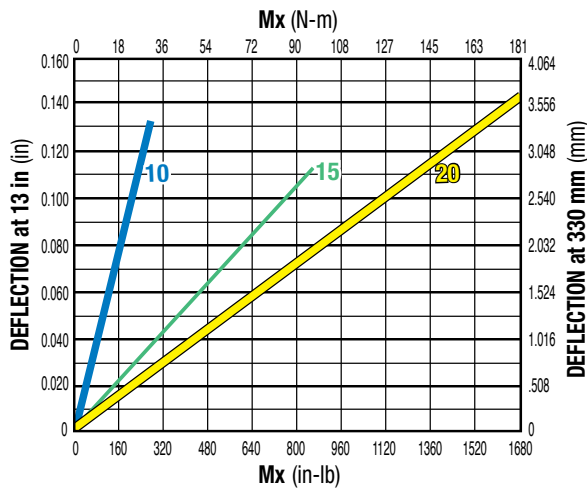
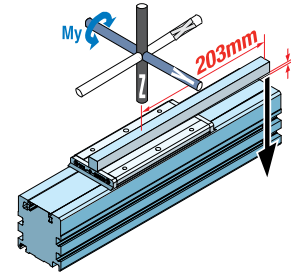

### SUPPORT RECOMMENDATIONS

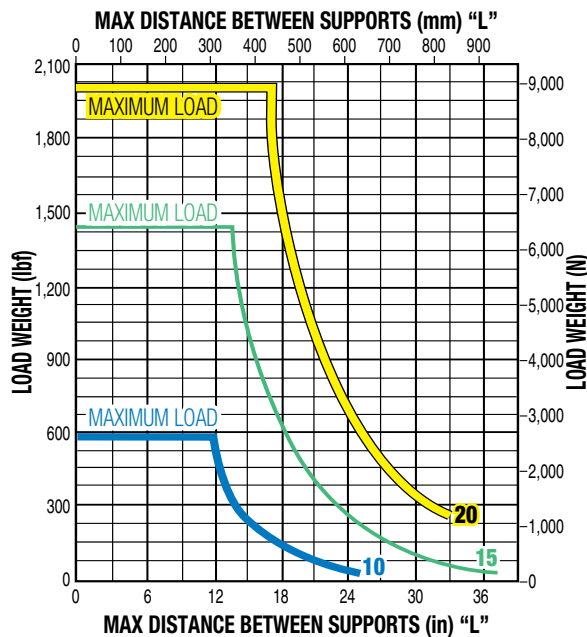

### FRICITION FORCE

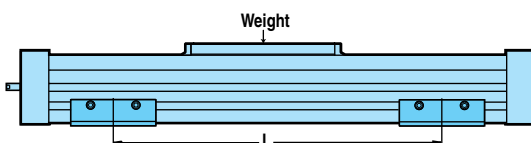
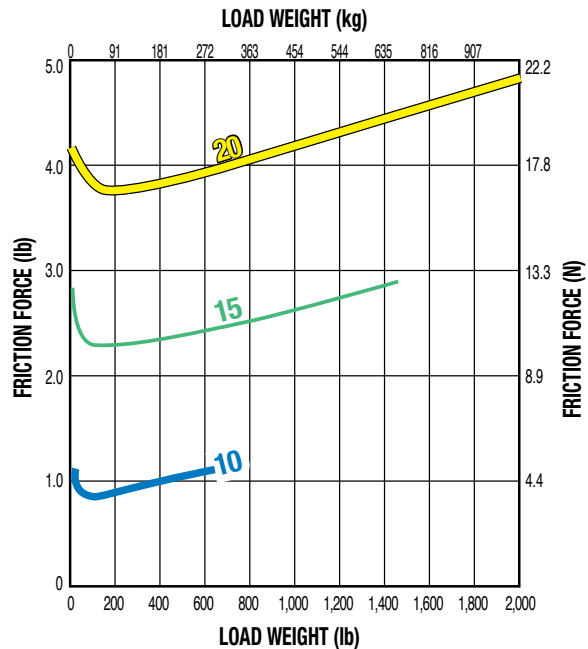

# B3S & B3W Electric Rodless Actuators

## SPECIFICATIONS both Screw & Belt Drive

sizeit.tolomatic.com for fast, accurate actuator selection

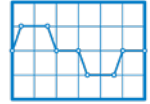

### AUXILIARY CARRIER: BENDING MOMENT AT 'D' DISTANCE

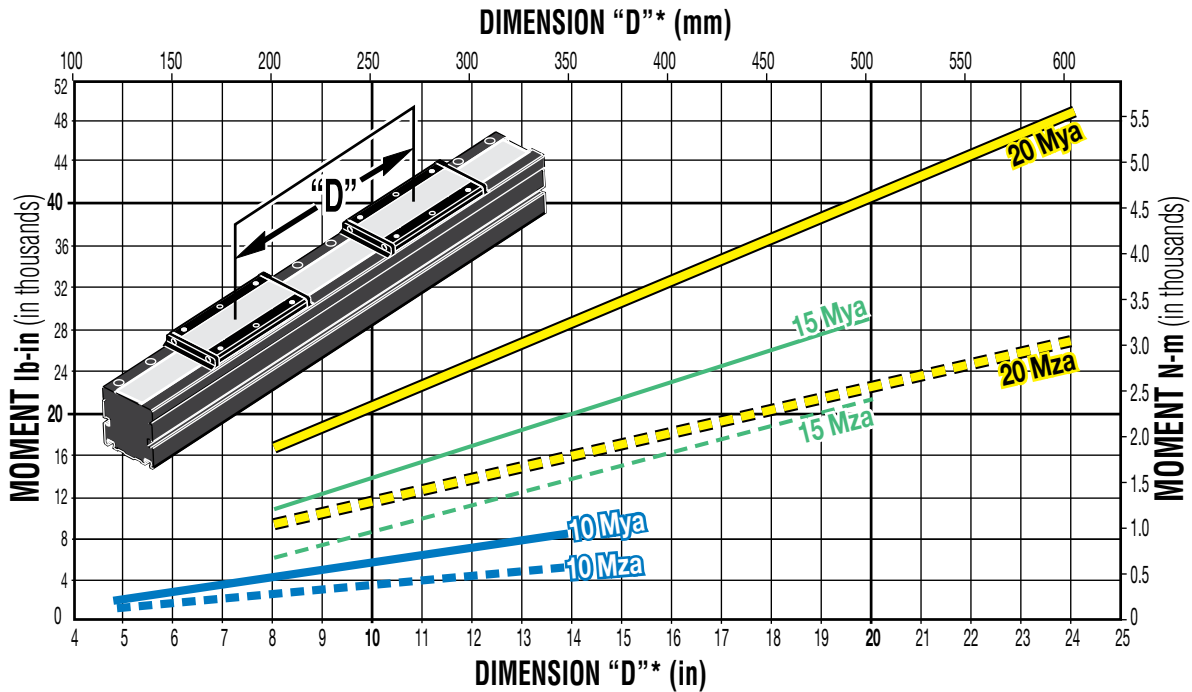

### AUXILIARY DUAL 180° CARRIER: BENDING MOMENT AT 'D' DISTANCE

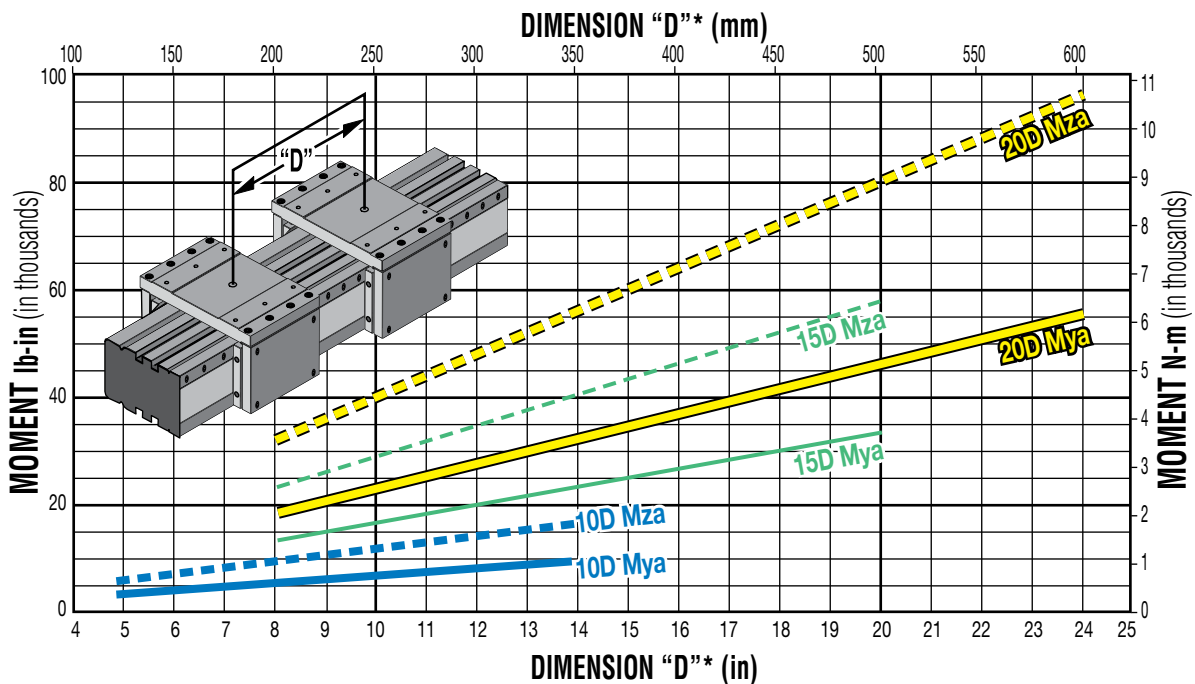

- Rates shown on both graphs were calculated with these assumptions:
- 1.) Coupling between carriers is rigid.
  - 2.) Load is equally distributed between carriers.
  - 3.) Coupling device applies no misalignment loads to carriers.
- \* Customer must specify Dimension "D" (Distance between carrier center lines) when ordering.

Life of the actuator will vary for each application depending on the combined loads, motion parameters and operating conditions. The load factor ( $L_f$ ) ratios for each application must not exceed a value of 1.5 (see formula at right). Exceeding a load factor of 1.5 will diminish the actuator's rated life.

$$L_f = \frac{M_x}{M_{x_{max}}} + \frac{M_y}{M_{y_{max}}} + \frac{M_z}{M_{z_{max}}} + \frac{F_y}{F_{y_{max}}} + \frac{F_z}{F_{z_{max}}} \leq 1.5$$

With combined loads,  $L_f$  must not exceed the value 1.5

# B3S Electric Screw Drive Rodless Actuators

## SPECIFICATIONS Related to Actuator Size and Screw Selection

### METRIC LEAD SCREWS

	SCREW DIA.	SCREW TYPE	LEAD	LEAD ACCURACY	BACKLASH	MAX THRUST*	MAX STROKE	INERTIA (kg-m <sup>2</sup> x 10 <sup>-6</sup> )			BREAKAWAY TORQUE
			(mm/turn)	(mm/300)				BASE ACTUATOR		PER/mm OF STROKE	
	(mm)			(mm)	(N)	(mm)	In Line	Rev. Parallel	(N-m)		
B3S10	10	BNM	10	0.10	0.06	1,832	1,630	1.14	1.43	0.176	0.13
	12	SN	12.0	0.13	0.18	800	3,459	3.03	4.50	0.410	0.20
B3S15	15	SN	12.0	0.13	0.18	900	3,388	11.35	12.96	0.966	0.27
	16	BN(L)	5.0	0.13	0.38	7,300	3,388	11.93	14.04	1.258	0.16
B3S20	20	BN(L)	5.0	0.13	0.38	11,700	3,337	36.97	39.28	3.102	0.25

(L) for low backlash ball screws: backlash = 0.05 mm

### INCH (US Conventional) LEAD SCREWS

	SCREW DIA.	SCREW TYPE	TPI	LEAD ACCURACY	BACKLASH	MAX THRUST*	MAX STROKE	INERTIA (lb-in <sup>2</sup> )			BREAKAWAY TORQUE
			(turns/in)	(in/ft)	(in)	(lbf)	(in)	BASE ACTUATOR		PER/in OF STROKE	
	(in)							In Line	Rev. Parallel		(lb-in)
B3S10	0.375	BN(L)	08	0.004	0.015	130	64.2	0.0034	0.0042	0.0005	1.125
	0.500	SN	05	0.006	0.007	170	136.2	0.0114	0.0142	0.0017	1.250
	0.500	SN	02	0.005	0.007	170	134.2	0.0159	0.0187	0.0017	1.750
	0.500	SNA	02	0.005	0.003	170	134.2	0.0193	0.0221	0.0017	1.750
	0.500	SN	01	0.006	0.007	170	100.2	0.0320	0.0348	0.0017	2.500
B3S15	0.500	BN(L)	02	0.003	0.015	800	61.4	0.0253	0.0282	0.0017	1.563
	0.625	BN(L)	05	0.003	0.015	800	61.4	0.0397	0.0467	0.0042	1.250
	0.625	SN	02	0.005	0.007	200	133.4	0.0480	0.0550	0.0042	1.875
	0.625	SNA	02	0.005	0.003	200	133.4	0.0480	0.0550	0.0042	1.875
	0.750	SN	01	0.005	0.007	300	133.4	0.1185	0.1329	0.0087	2.813
B3S20	0.750	BN(L)	02	0.004	0.015	2,700	131.4	0.1159	0.1224	0.0087	3.125
	0.750	BN(L)	05	0.003	0.015	950	131.4	0.1045	0.1110	0.0087	2.188

(L) for low backlash ball screws: backlash = 0.0020"

SCREW CODE	DESCRIPTION
SN	Solid Nut
SNA	Anti-backlash Solid Nut
BN	Ball Nut
BNL	Low-Backlash Ball Nut

Contact Tolomatic for higher accuracy and lower backlash options.

\* For Acme screws, maximum thrust is the maximum continuous dynamic thrust subject to Thrust x Velocity limitation.

For ball screws, maximum thrust reflects 90% reliability for 25 million linear millimeters of travel.

B3S

B3W

# B3S Electric Screw Drive Rodless Actuators

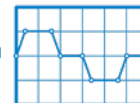

## SPECIFICATIONS

sizeit.tolomatic.com for fast, accurate actuator selection

### METRIC

	WEIGHT		WEIGHT PER UNIT OF STROKE	<sup>1</sup> STRAIGHTNESS & FLATNESS (supported)	<sup>2</sup> TEMPERATURE RANGE	<sup>3</sup> IP RATING
	CARRIER	BASE				
	(kg)	(kg)	(g/mm)	(mm)	(°C)	
<b>B3S10</b>	0.40	1.00	5.40	0.00067 x L*	4 - 54	44
<b>B3S15</b>	0.70	3.96	10.18			
<b>B3S20</b>	0.97	6.52	15.73			

	WEIGHT		WEIGHT PER UNIT OF STROKE
	CARRIER	BASE	
	(kg)	(kg)	(g/mm)
<b>B3S10D</b>	1.05	2.31	7.32
<b>B3S15D</b>	2.93	6.53	12.14
<b>B3S20D</b>	4.83	13.36	23.30



<sup>1</sup>The listed values relating to straightness/flatness are intended for reference purposes only, and not as an engineering standard of absolute tolerance for a given actuator. Appropriate installation is the single most important factor in reducing such deviation, so good engineering practices such as measurement, mapping, etc. must be employed in applications with stringent straightness/flatness requirements.

<sup>2</sup> Heat generated by the motor and drive should be taken into consideration as well as linear velocity and work cycle time. For applications that require operation outside of the recommended temperature range, contact the factory.

### INCH (US Conventional)

	WEIGHT		WEIGHT PER UNIT OF STROKE	<sup>1</sup> STRAIGHTNESS & FLATNESS (supported)	<sup>2</sup> TEMPERATURE RANGE	<sup>3</sup> IP RATING
	CARRIER	BASE				
	(lbs)	(lbs)	(lbs/in)	(in)	(°F)	
<b>B3S10</b>	0.85	2.15	0.30	0.00067 x L*	40 - 130	44
<b>B3S15</b>	1.56	8.75	0.57			
<b>B3S20</b>	2.15	14.38	0.88			

	WEIGHT		WEIGHT PER UNIT OF STROKE
	CARRIER	BASE	
	(lbs)	(lbs)	(lbs/in)
<b>B3S10D</b>	2.32	5.10	0.41
<b>B3S15D</b>	6.47	14.40	0.68
<b>B3S20D</b>	10.65	29.45	1.31

<sup>3</sup> Protected against ingress of solid particles greater than .039 in (1mm) and splashing water.

\* "L" is maximum distance between supports— See the support recommendation graph on page B3\_9.

**LARGE FRAME MOTORS AND SMALLER SIZE ACTUATORS:** Cantilevered motors need to be supported, if subjected to continuous rapid reversing duty and/or under dynamic conditions.

## LEAD SCREW EFFICIENCY

SCREW/NUT STYLE	SIZE		
	10	15	20
Composite (ACME)	0.60		
Ball	0.90		
Ball Low Backlash	0.85		

B3S

B3W

# B3S Electric Screw Drive Rodless Actuators

## ACME SCREW/NUT COMBINATIONS

sizeit.tolomatic.com for fast, accurate actuator selection

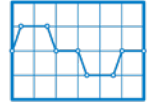

### ACME SCREW CRITICAL SPEED CAPACITIES

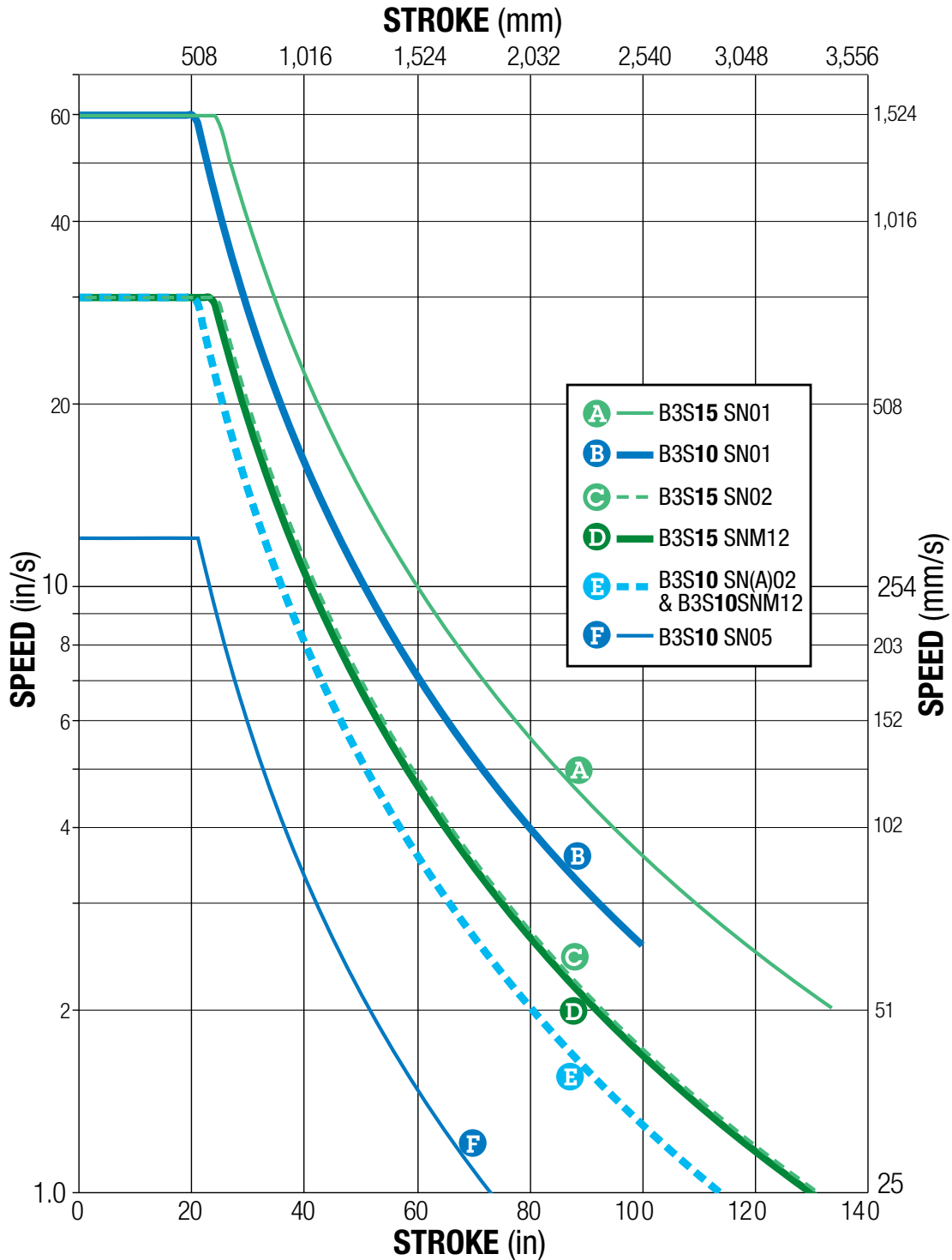

\* Maximum thrust is the maximum continuous dynamic thrust subject to Thrust x Velocity limitation.

Dotted lines represent maximum stroke for screw selections.

For Screw PV limits, refer to the individual charts located in the technical section for each actuator body size.

SCREW CODE	DESCRIPTION
SNM	Solid Nut
SNA	Anti-backlash Solid Nut

B3S

B3W

# B3S Electric Screw Drive Rodless Actuators

## ACME SCREW/NUT COMBINATIONS

sizeit.tolomatic.com for fast, accurate actuator selection

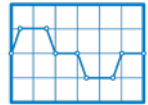

### ACME SCREW PV LIMITS

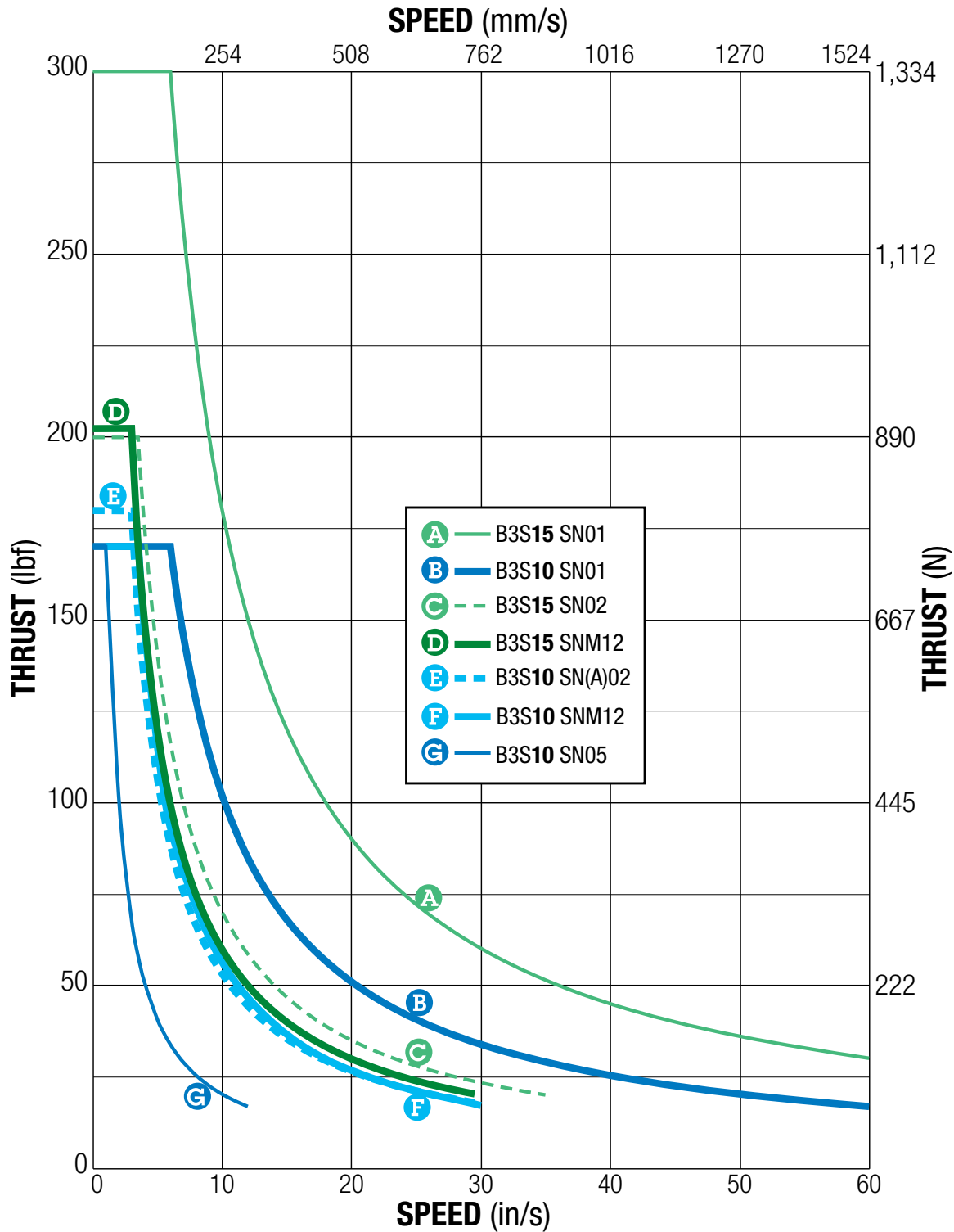

**▲** \* Maximum thrust is the maximum continuous dynamic thrust subject to Thrust x Velocity Limitation.

PV LIMITS: Any material which carries a sliding load is limited by heat buildup. The factors that affect heat generation rate in an application are the pressure on the nut in pounds per square inch and the surface velocity in feet per minute. The product of these factors provides a measure of the severity of an application.

$$\left( \frac{P}{(\text{Max. Thrust Rating})} \right) \times \left( \frac{V}{(\text{Max. Speed Rating})} \right) \leq 0.1$$

# B3S Electric Screw Drive Rodless Actuators

## BALL SCREW/NUT COMBINATIONS

sizeit.tolomatic.com for fast, accurate actuator selection

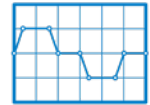

### BALL SCREW CRITICAL SPEED CAPACITIES

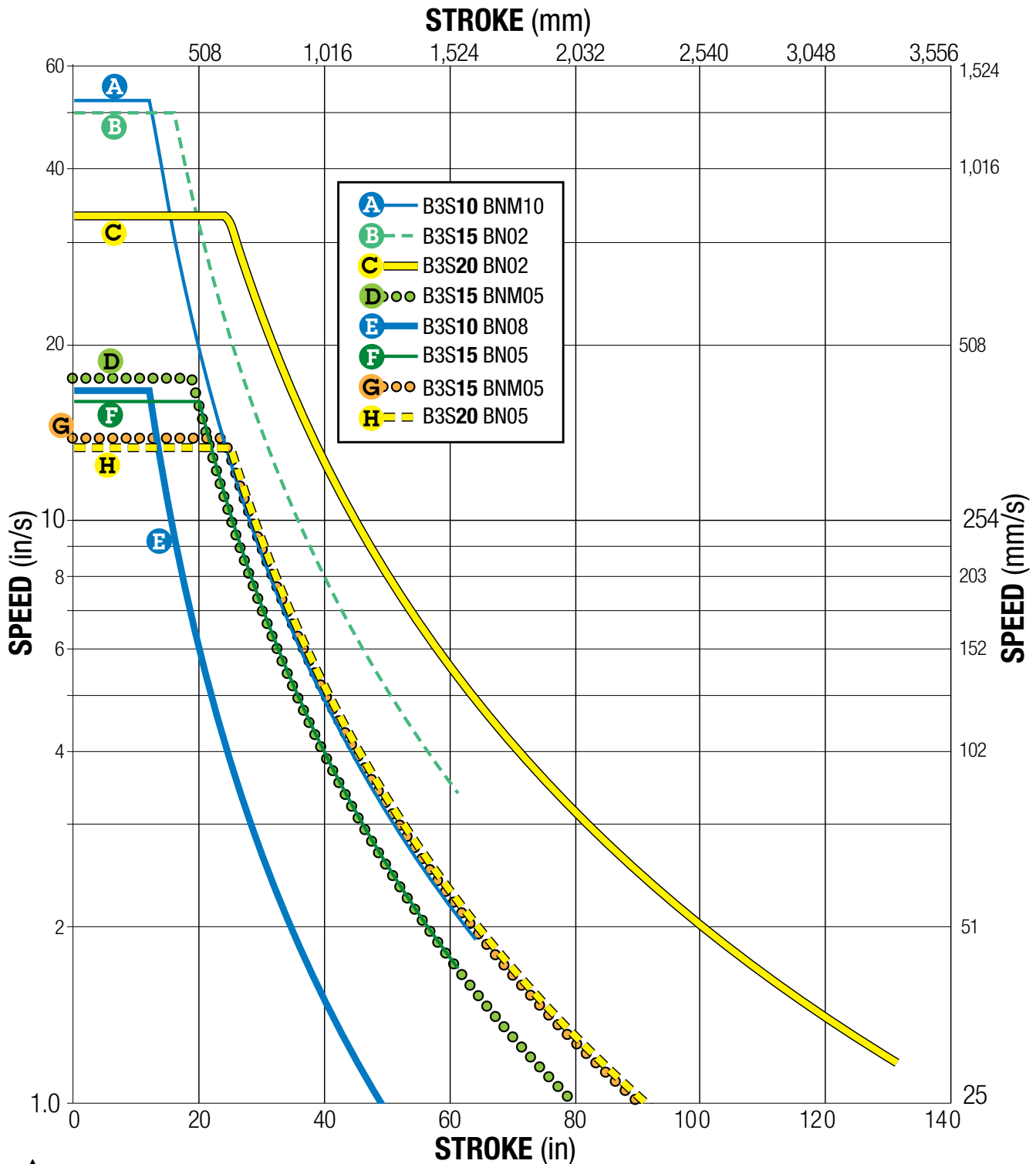

\* Maximum thrust reflects 90% reliability for 25 million linear millimeters of travel.

Dotted lines represent maximum stroke for screw selections.

SCREW CODE	DESCRIPTION
BN/BNM	Ball Nut
BNL/BNML	Low-Backlash Ball Nut

B3S

B3W

# B3S Electric Screw Drive Rodless Actuators

## BALL SCREW/NUT COMBINATIONS

sizeit.tolomatic.com for fast, accurate actuator selection

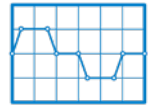

### BALL SCREW LIFE CAPACITIES

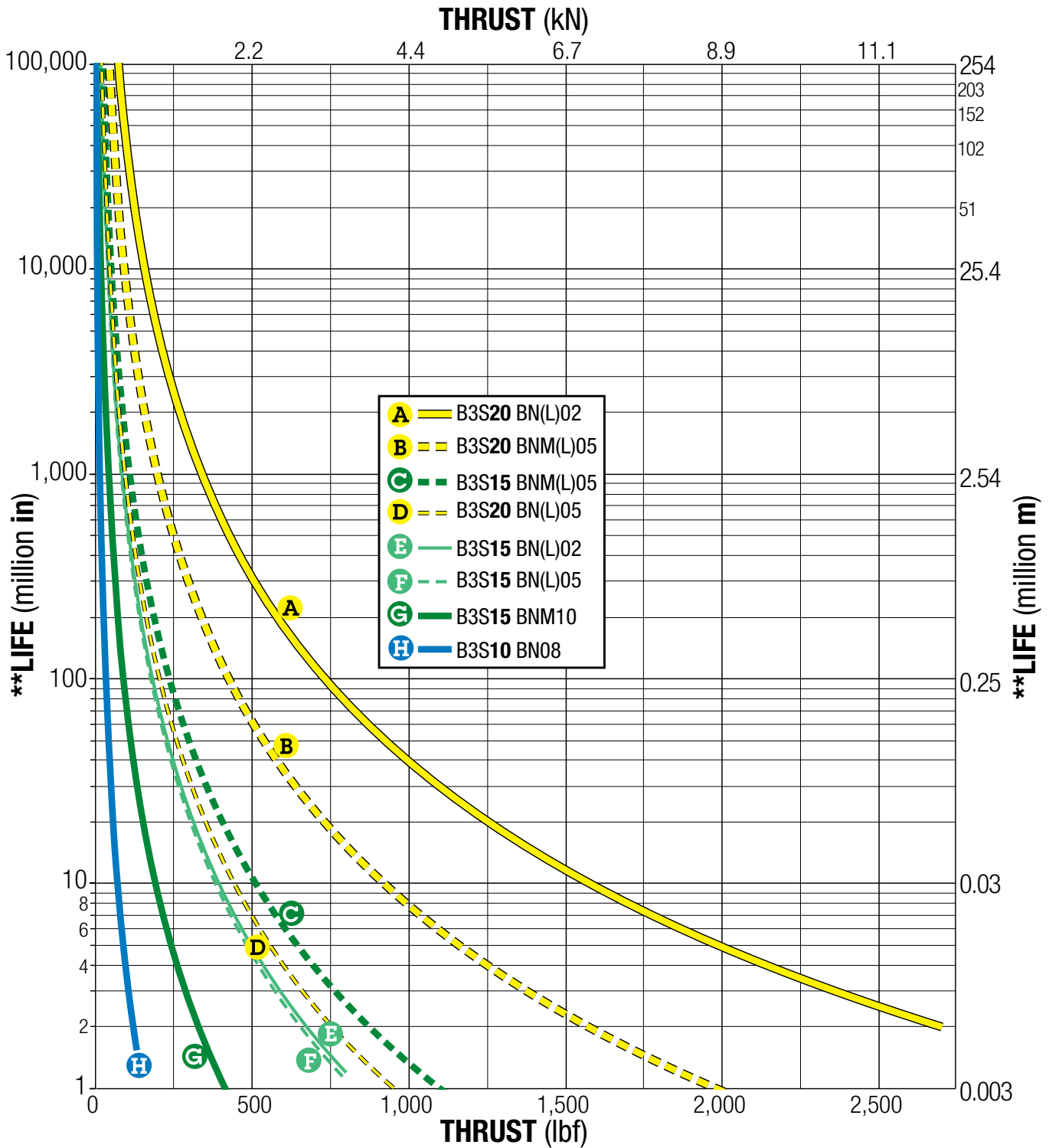

**!** \* Maximum thrust reflects 90% reliability for 25 million linear millimeters of travel.

Dotted lines represent maximum thrust for screw selections.

\*\*Life indicates theoretical maximum life of screw only, under ideal conditions and does not indicate expected life of actuator.

# B3S10 Electric Screw Drive Rodless Actuators

## DIMENSIONS Actuator & Options

3D CAD available at [www.tolomatic.com](http://www.tolomatic.com)

Always use configured CAD solid model to determine critical dimensions

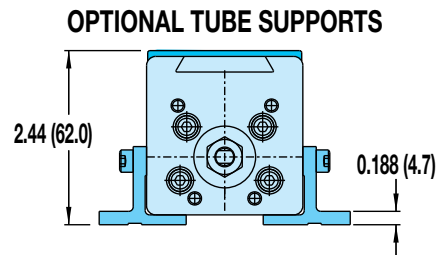
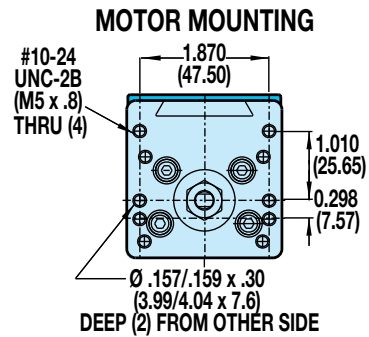
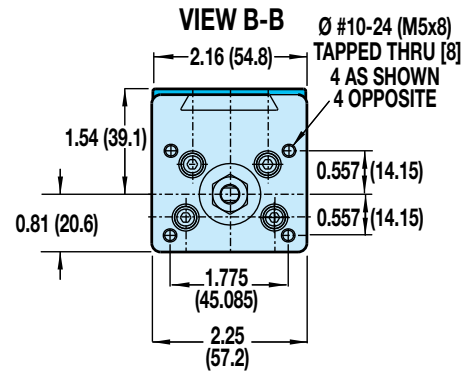
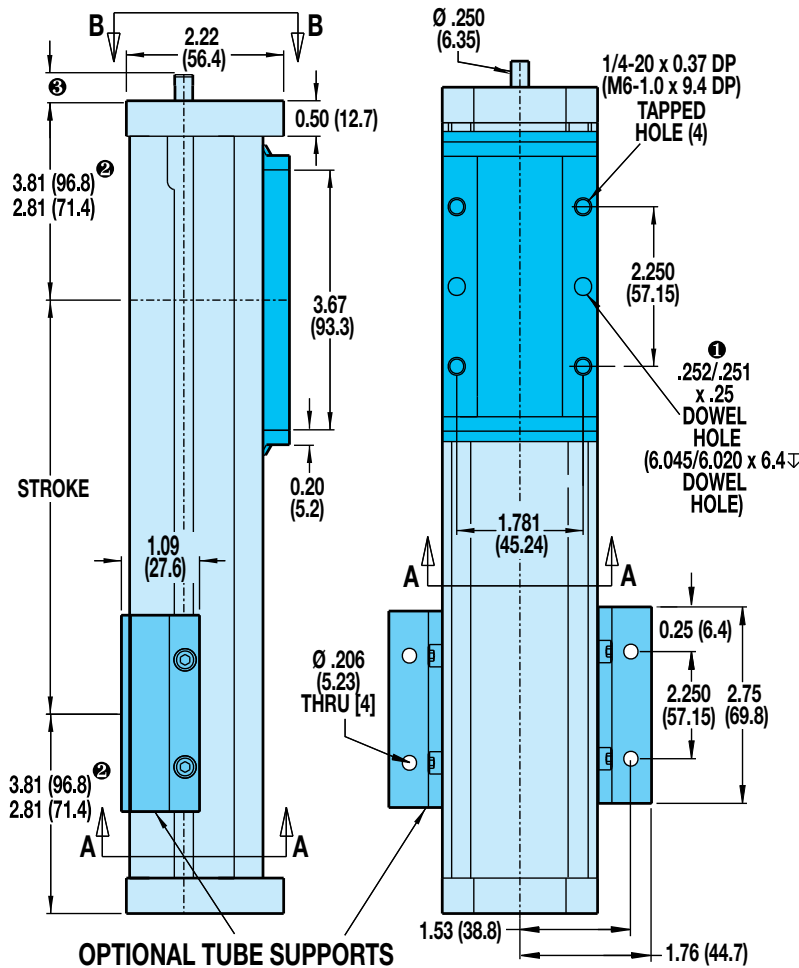

**SILVER NUTS FOR SLOTS 90° FROM CARRIER**  
#3410-1013 [4410-1013]

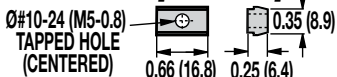

**YELLOW NUTS FOR SLOTS OPPOSITE CARRIER**  
#3410-1775 [4410-1708]

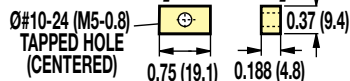

**OPTIONAL SWITCH MOUNTING** ⚠️ Ⓜ️ Ⓟ

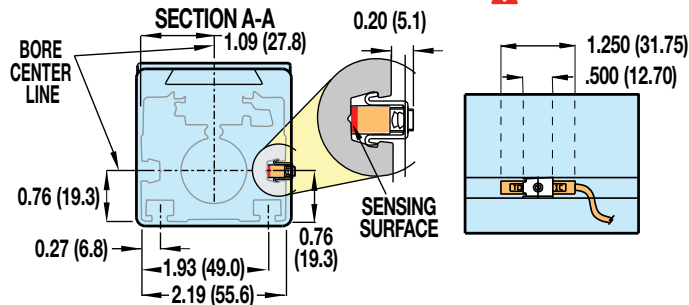

**OPTIONAL MOUNTING PLATES**

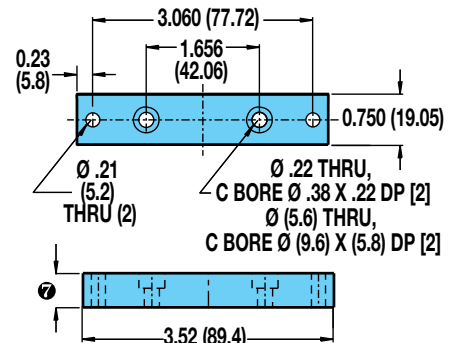

① DOWEL PINS Ⓜ️ .003 (08mm) Ⓜ️

② FOR SNAO2 STYLE ONLY

③ SHAFT LENGTH

In-line mounting	0.55 (13.8)
Extended shaft for RP & 23-frame motor	1.99 (50.5)
Extended shaft for RP & 34-frame motor	2.20 (55.9)
Extended shaft for purchases prior to 6/24/02	1.63 (41.4)

⚠️ **CAUTION: DO NOT OVERTIGHTEN SWITCH HARDWARE WHEN INSTALLING**

Ⓟ **NOTE:** The scored face of the switch indicates the sensing surface and must face toward the magnet

Ⓜ️ **NOTE:** Some actuators require switch mounting on a specific side of the actuator. Call Tolomatic 1-800-328-2174 for details

Ⓡ **LMI with MRS is 1" (25.4mm) thick**  
LMI with all others is 1/2" (12.7mm) thick  
RP, (YMH) all motors is 1/2" (12.7mm) thick

Unless otherwise noted, all dimensions shown are in inches (Dimensions in parenthesis are in millimeters)

# B3S10 Electric Screw Drive Rodless Actuators

## DIMENSIONS Dual 180° Option

3D CAD available at [www.tolomatic.com](http://www.tolomatic.com)

Always use configured CAD solid model to determine critical dimensions

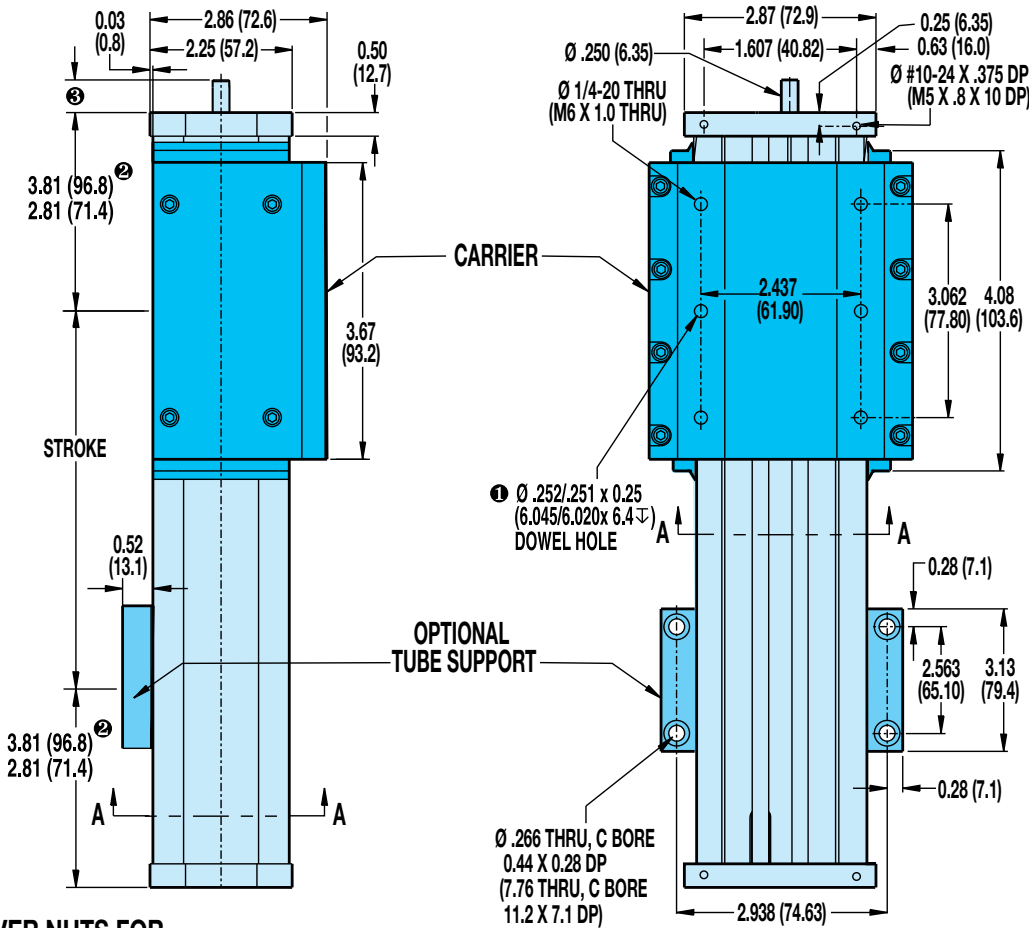

### SILVER NUTS FOR SLOTS 90° FROM CARRIER #3410-1013 [4410-1013]

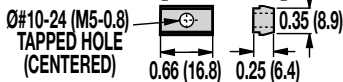

### OPTIONAL SWITCH MOUNTING

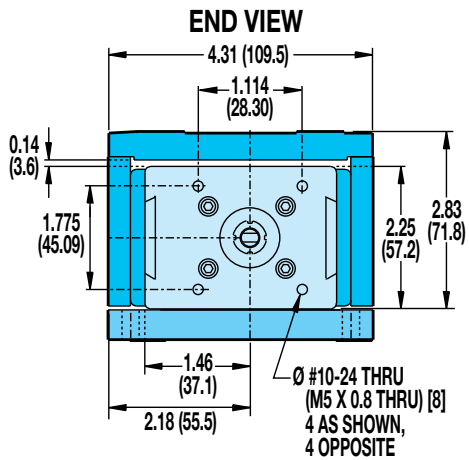
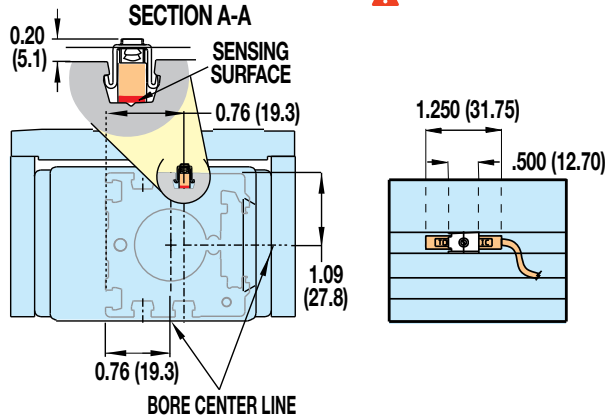

- ① DOWEL PINS  $\oplus$  .003 (08mm) (M)
  - ② FOR SNA02 STYLE ONLY
  - ③ SHAFT LENGTH
- |   |             |
|---|-------------|
| In-line mounting                              | 0.55 (13.8) |
| Extended shaft for RP & 23-frame motor        | 1.99 (50.5) |
| Extended shaft for RP & 34-frame motor        | 2.20 (55.9) |
| Extended shaft for purchases prior to 6/24/02 | 1.63 (41.4) |

⚠ CAUTION: DO NOT OVERTIGHTEN SWITCH HARDWARE WHEN INSTALLING

⑤ NOTE: The scored face of the switch indicates the sensing surface and must face toward the magnet

⑥ NOTE: Some actuators require switch mounting on a specific side of the actuator. Call Tolomatic 1-800-328-2174 for details

# B3S15 Electric Screw Drive Rodless Actuators



## DIMENSIONS Actuator & Options

3D CAD available at [www.tolomatic.com](http://www.tolomatic.com)  
Always use configured CAD solid model to determine critical dimensions

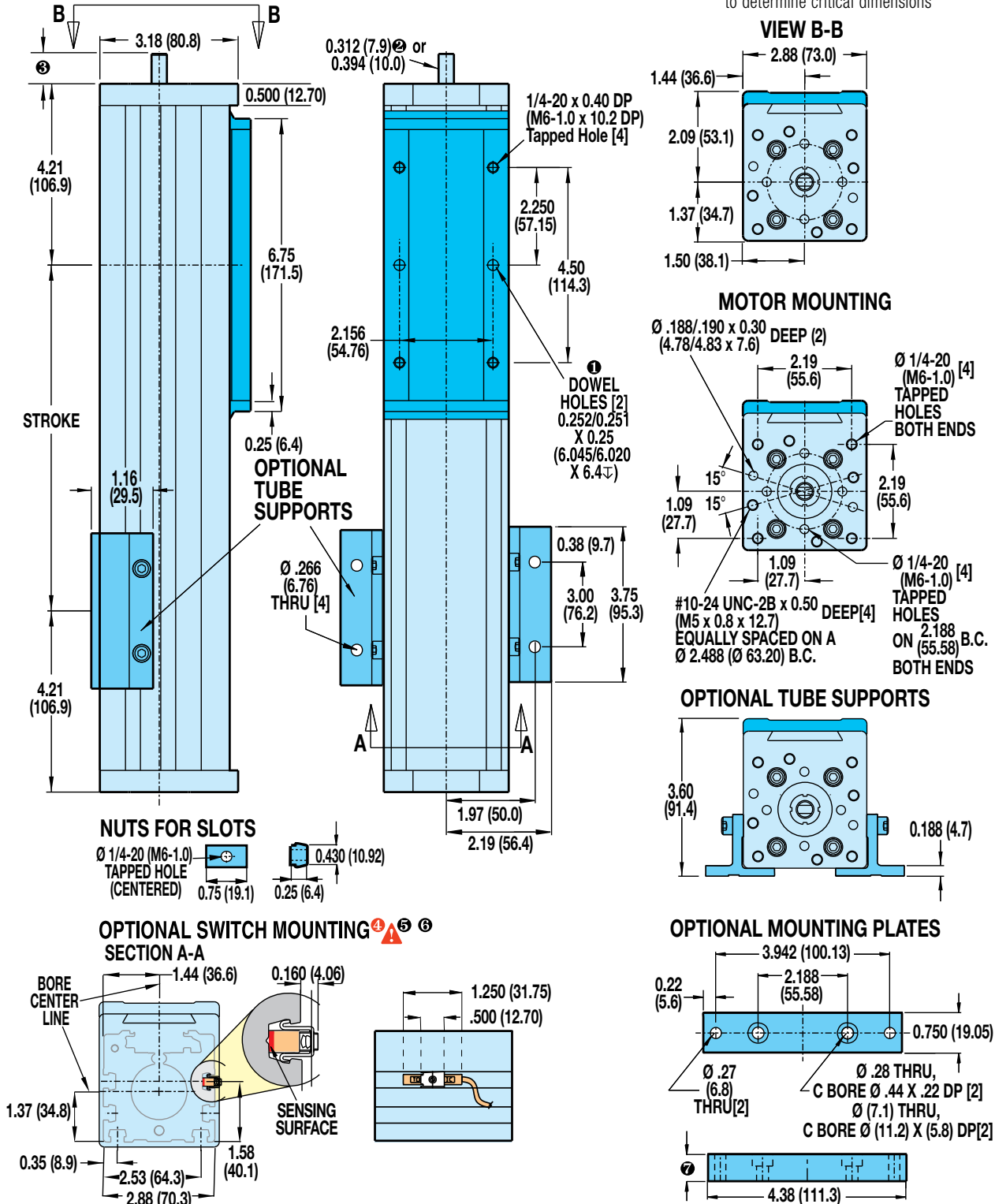

① DOWEL PINS  $\pm .003$  (08mm) (M)

② FOR B3S15BN02 & B3S15BNL02

③ SHAFT LENGTH

In-line mounting	0.69 (17.5)
Extended shaft for RP & 23-frame motor	1.99 (50.5)
Extended shaft for RP & 34-frame motor	2.20 (55.9)
Extended shaft for purchases prior to 6/24/02	1.95 (49.5)

④ **CAUTION: DO NOT OVERTIGHTEN SWITCH HARDWARE WHEN INSTALLING**

⑤ NOTE: The scored face of the switch indicates the sensing surface and must face toward the magnet

⑥ NOTE: Some actuators require switch mounting on a specific side of the actuator. Call Tolomatic 1-800-328-2174 for details

⑦ LMI with MRS3 is 1" (25.4mm) thick  
LMI with all others is 1/2" (12.7mm) thick  
RP, (YMH) all motors is 1/2" (12.7mm) thick

Unless otherwise noted, all dimensions shown are in inches (Dimensions in parenthesis are in millimeters)

# B3S15 Electric Screw Drive Rodless Actuators

## DIMENSIONS Dual 180° Option

3D CAD available at [www.tolomatic.com](http://www.tolomatic.com)

Always use configured CAD solid model to determine critical dimensions

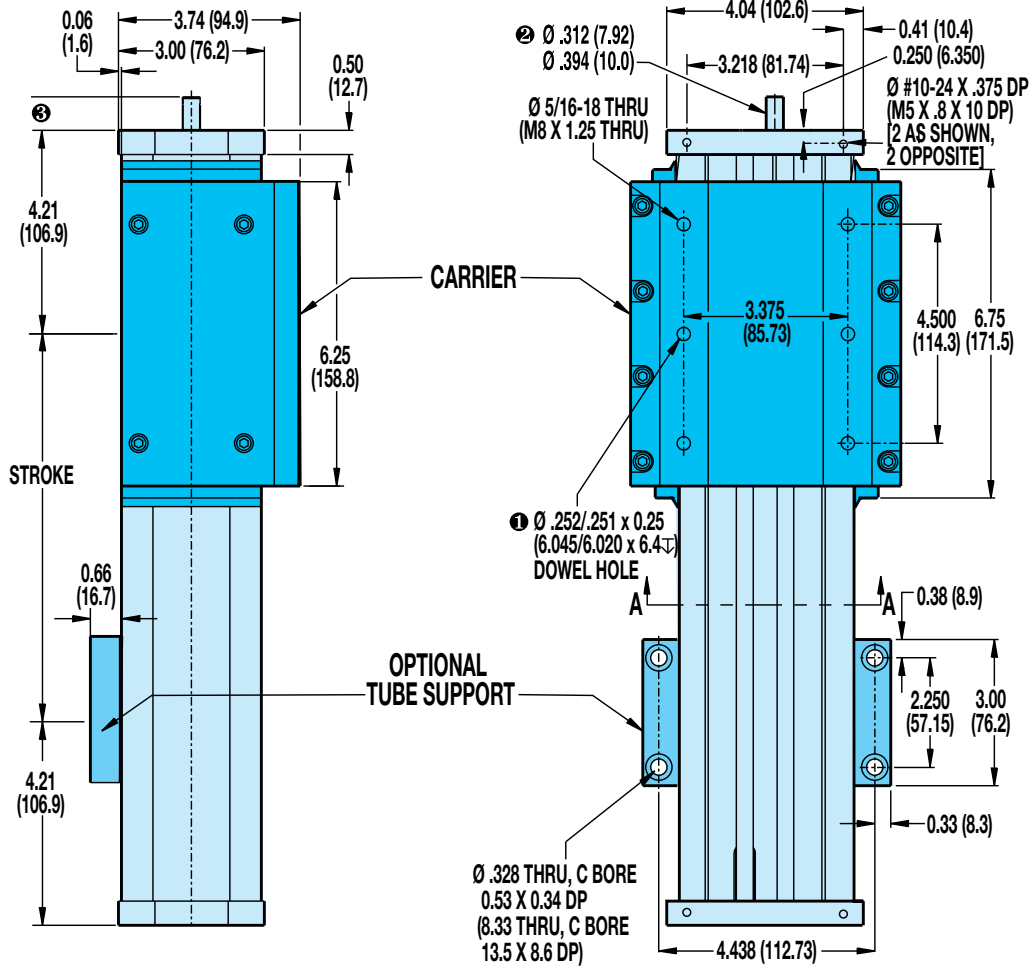

### NUTS FOR SLOTS



### OPTIONAL SWITCH MOUNTING <sup>4</sup> <sup>5</sup> <sup>6</sup>

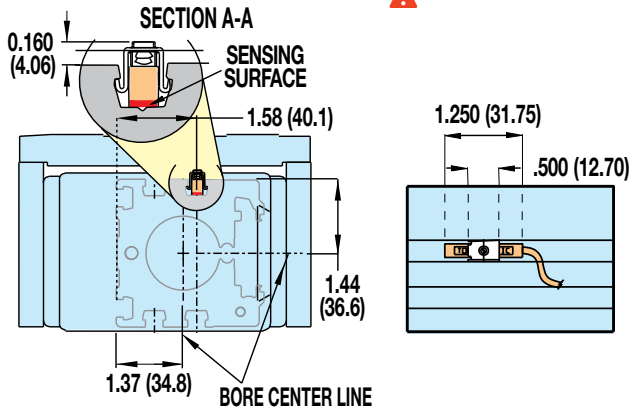

#### 1 DOWEL PINS

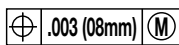

2 FOR B3S15BN02 & B3S15BNL02

#### 3 SHAFT LENGTH

In-line mounting	0.69 (17.5)
Extended shaft for RP & 23-frame motor	1.99 (50.5)
Extended shaft for RP & 34-frame motor	2.20 (55.9)
Extended shaft for purchases prior to 6/24/02	1.95 (49.5)

<sup>4</sup> **CAUTION: DO NOT OVERTIGHTEN SWITCH HARDWARE WHEN INSTALLING**

<sup>5</sup> **NOTE: The scored face of the switch indicates the sensing surface and must face toward the magnet**

<sup>6</sup> **NOTE: Some actuators require switch mounting on a specific side of the actuator. Call Tolomatic 1-800-328-2174 for details**

# B3S20 Electric Screw Drive Rodless Actuators

## DIMENSIONS Actuator & Options

3D CAD available at [www.tolomatic.com](http://www.tolomatic.com)

Always use configured CAD solid model to determine critical dimensions

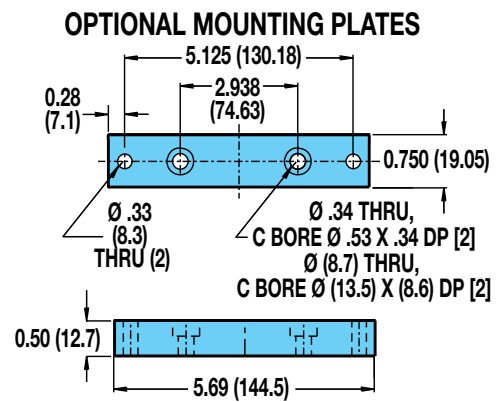
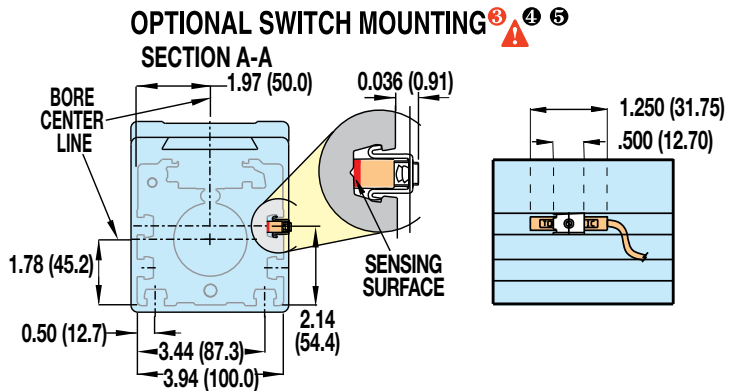
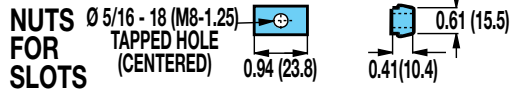
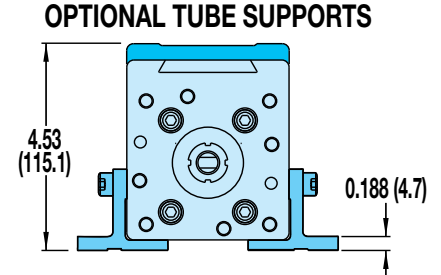
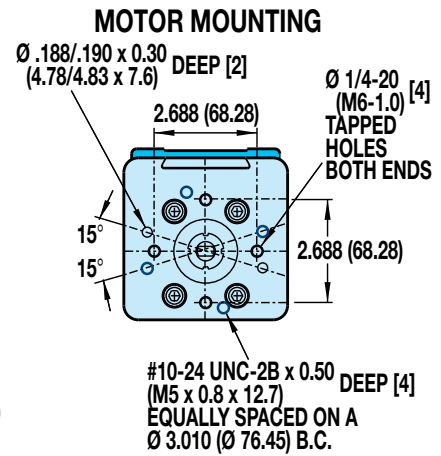
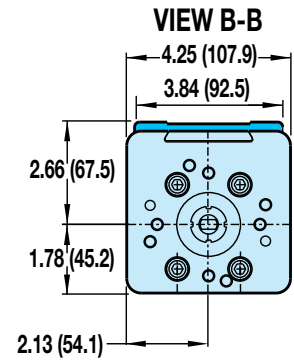
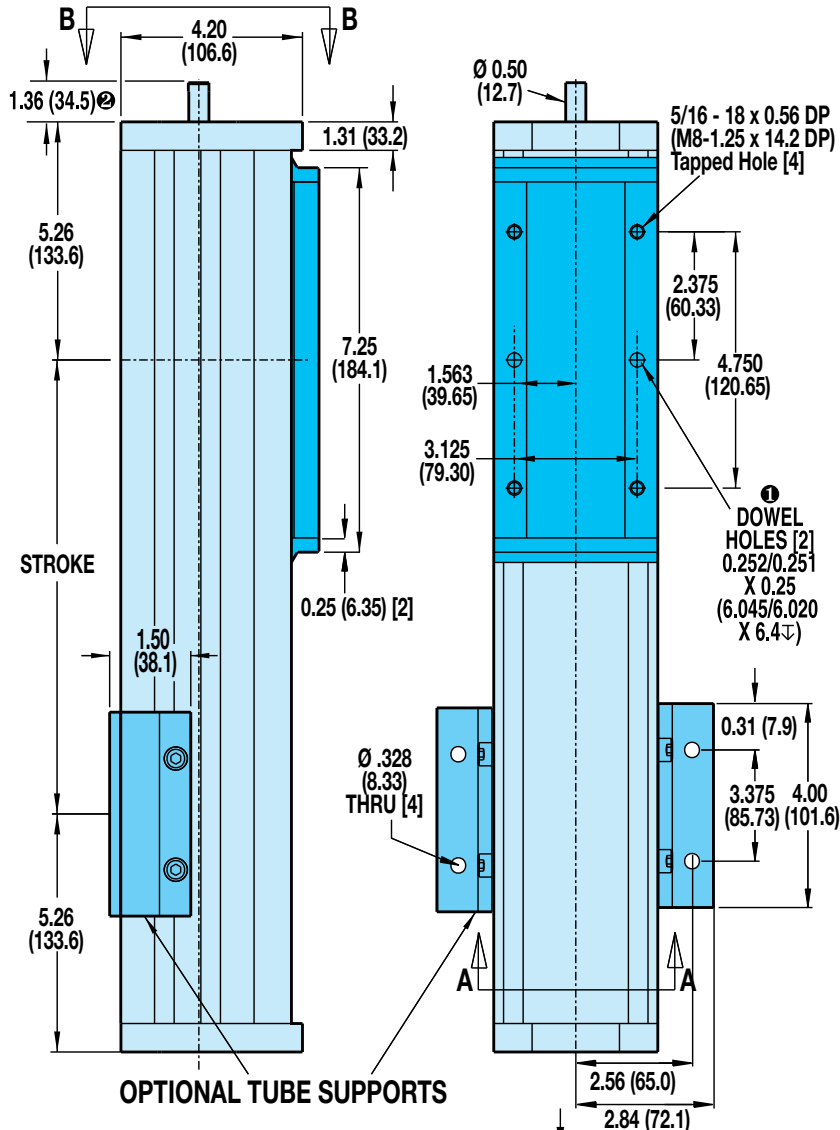

- ① DOWEL PINS  $\text{Ø} .003 (08\text{mm}) \text{ (M)}$
- ② FOR EXTENDED SHAFT 2.11 (53.6)
- ⚠ **CAUTION: DO NOT OVERTIGHTEN SWITCH HARDWARE WHEN INSTALLING**
- ④ NOTE: The scored face of the switch indicates the sensing surface and must face toward the magnet
- ⑤ NOTE: Some actuators require switch mounting on a specific side of the actuator. Call Tolomatic 1-800-328-2174 for details

B3S

B3W

# B3S20 Electric Screw Drive Rodless Actuators

## DIMENSIONS Dual 180° Option

3D CAD available at [www.tolomatic.com](http://www.tolomatic.com)

Always use configured CAD solid model to determine critical dimensions

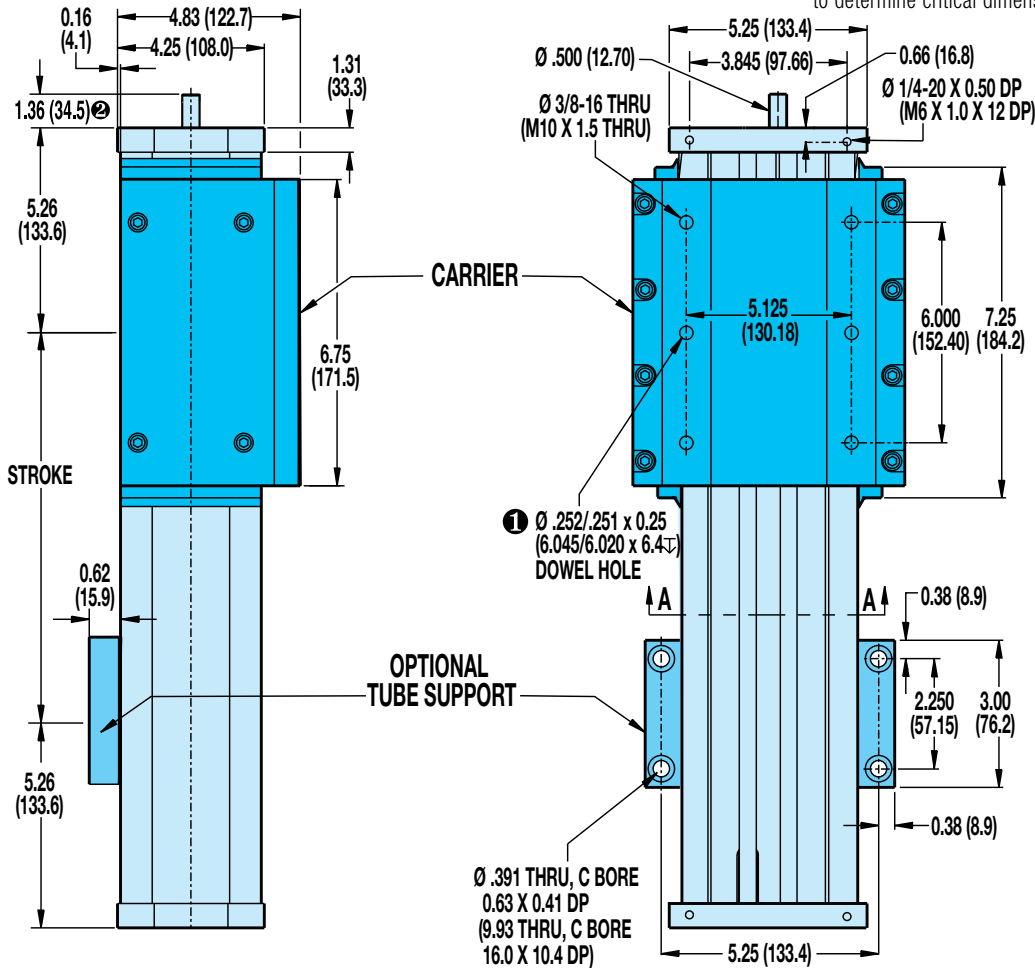

### NUTS FOR SLOTS



### OPTIONAL SWITCH MOUNTING

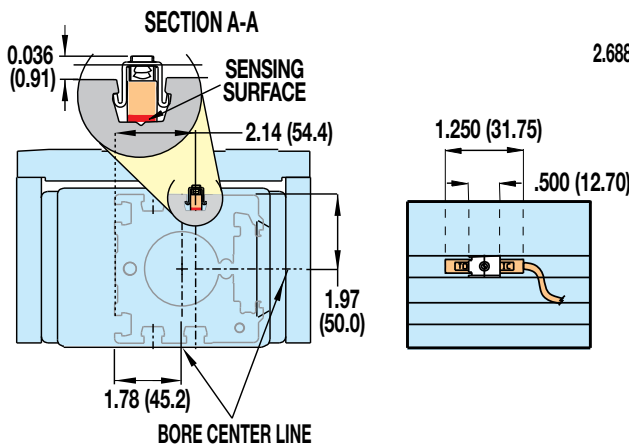

### END VIEW

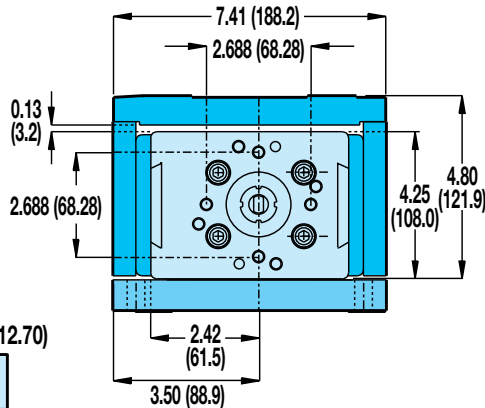

- ① DOWEL PINS  $\pm .003$  (08mm) (M)
- ② FOR EXTENDED SHAFT 2.11 (53.6)

- ⚠ CAUTION: DO NOT OVERTIGHTEN SWITCH HARDWARE WHEN INSTALLING
- ④ NOTE: The scored face of the switch indicates the sensing surface and must face toward the magnet

- ⑤ NOTE: Some actuators require switch mounting on a specific side of the actuator. Call Tolomatic 1-800-328-2174 for details

B3S

B3W

# B3S Electric Screw Drive Rodless Actuators

## DIMENSIONS Actuator & Options

3D CAD available at [www.tolomatic.com](http://www.tolomatic.com)

Always use configured CAD solid model to determine critical dimensions



### B3S10: IN-LINE MOUNT FOR MOTORS OR GEARBOXES

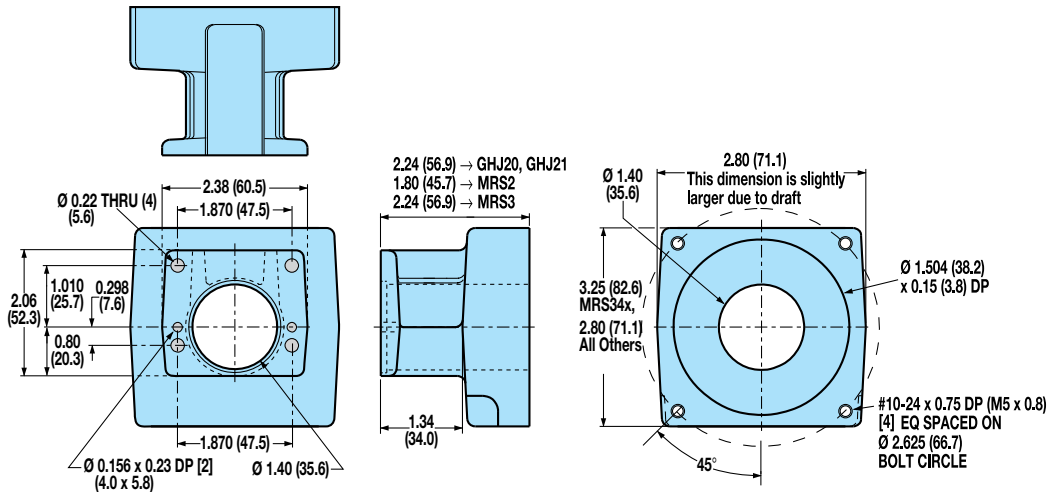

### B3S15: IN-LINE MOUNT FOR MOTORS OR GEARBOXES

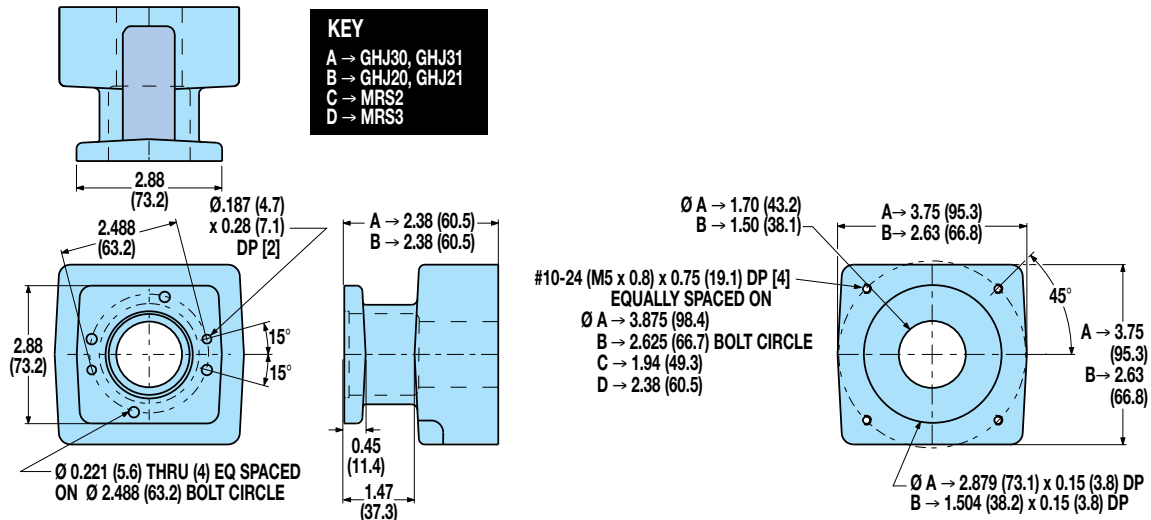

### B3S20: IN-LINE MOUNT FOR MOTORS OR GEARBOXES

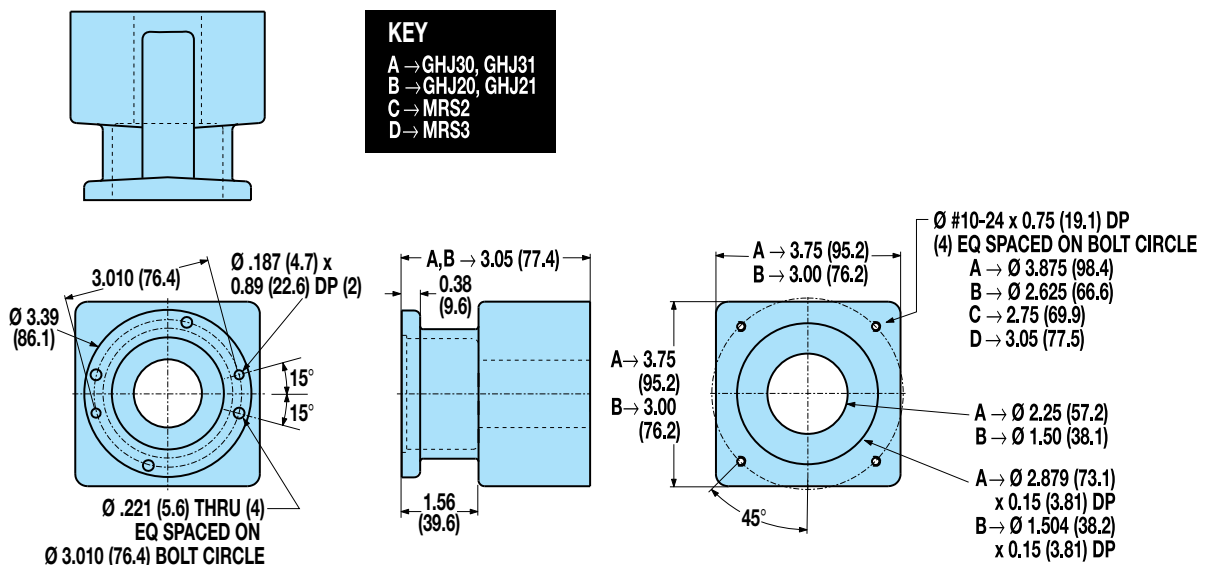

B3S

B3W

# B3S Electric Screw Drive Rodless Actuators

## DIMENSIONS Reverse Parallel Mounting

3D CAD available at [www.tolomatic.com](http://www.tolomatic.com)  
Always use configured CAD solid model to determine critical dimensions



### STANDARD CARRIER

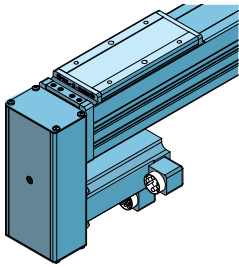

**REVERSE-PARALLEL BOTTOM (RPB)**  
mounting surface shown up

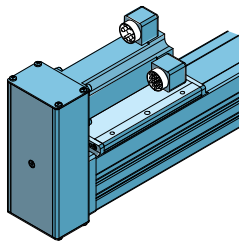

**REVERSE-PARALLEL TOP (RPT)\***  
mounting surface shown up

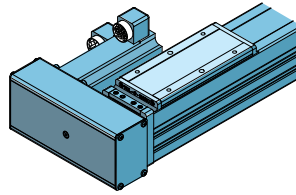

**REVERSE-PARALLEL LEFT (RPL)**  
mounting surface shown up

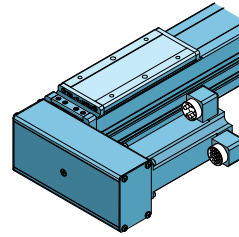

**REVERSE-PARALLEL RIGHT (RPR)**  
mounting surface shown up

### BOTTOM MOUNT

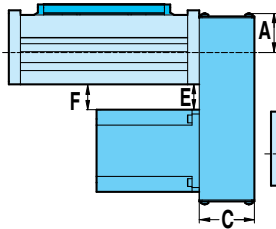

### TOP MOUNT

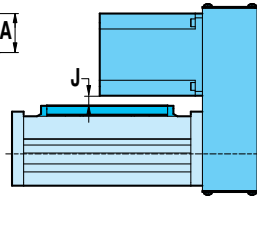

### SIDE MOUNT (Right Shown)

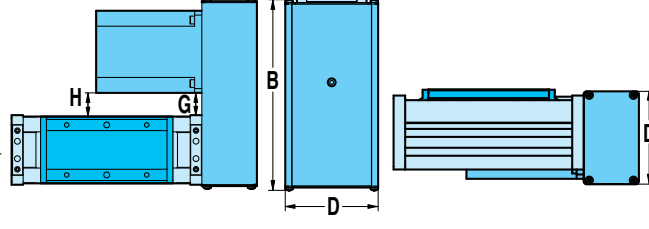

### DUAL 180° CARRIER

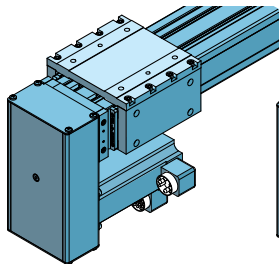

**REVERSE-PARALLEL BOTTOM (RPB)**  
mounting surface shown up

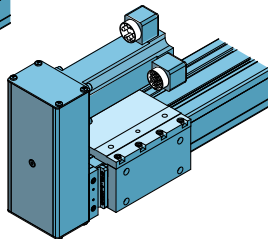

**REVERSE-PARALLEL TOP (RPT)\***  
mounting surface shown up

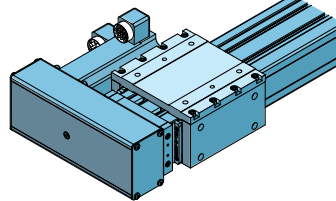

**REVERSE-PARALLEL LEFT (RPL)**  
mounting surface shown up

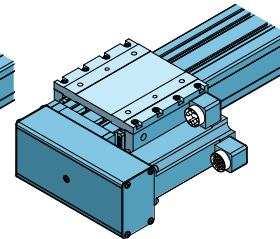

**REVERSE-PARALLEL RIGHT (RPR)**  
mounting surface shown up

#### Reduction Drive Weight

		kg	lb
10	1:1 & 2:1 Ratio	0.93	2.06
	1:1 Ratio	0.98	2.17
15	2:1 Ratio	1.09	2.40
	1:1 Ratio	1.39	3.07
20	2:1 Ratio	1.47	3.23
	1:1 Ratio	1.42	3.13
	1:1 Ratio	1.42	3.13
	2:1 Ratio	1.49	3.29

#### Reduction Inertia at Motor Shaft

		kg-cm <sup>2</sup>	lb-in <sup>2</sup>
10	1:1 Ratio	0.2559	0.0875
	2:1 Ratio	0.3291	0.1125
15	1:1 Ratio	0.2043	0.0700
	2:1 Ratio	0.2767	0.0950
20	1:1 Ratio	0.3447	0.1180
	2:1 Ratio	0.2928	0.1000

\*NOTE: RPT is generally not recommended because the load may interfere with the motor. Stops or spacers may be required.

Reduction Efficiency: 0.95

Frame Size	A	B	C	D	E	F	G	H	J	
10	23	42.6	178.6	54.0	82.6	45.6	46.8	37.6	38.4	26.9
15	23	36.6	191.3	54.0	82.6	44.1	44.1	40.8	42.3	25.3
	34	53.8	208.6	60.3	101.6	27.7	27.7	24.4	25.9	8.9
20	23	63.8	238.4	60.3	101.6	59.5	59.6	50.8	54.7	37.2
	34	63.8	251.5	60.3	101.6	43.2	43.2	34.4	38.4	20.9

Dimensions in millimeters

Frame Size	A	B	C	D	E	F	G	H	J	
10	23	1.68	7.03	2.13	3.25	1.80	1.84	1.48	1.51	1.06
15	23	1.44	7.53	2.13	3.25	1.74	1.74	1.61	1.67	1.00
	34	2.12	8.21	2.38	4.00	1.09	1.09	0.96	1.02	0.35
20	23	2.51	9.38	2.38	4.00	2.34	2.35	2.00	2.16	1.47
	34	2.51	9.90	2.38	4.00	1.70	1.70	1.36	1.51	0.82

Dimensions in inches

# B3W Electric Belt Drive Rodless Actuators

sizeit.tolomatic.com for fast, accurate actuator selection

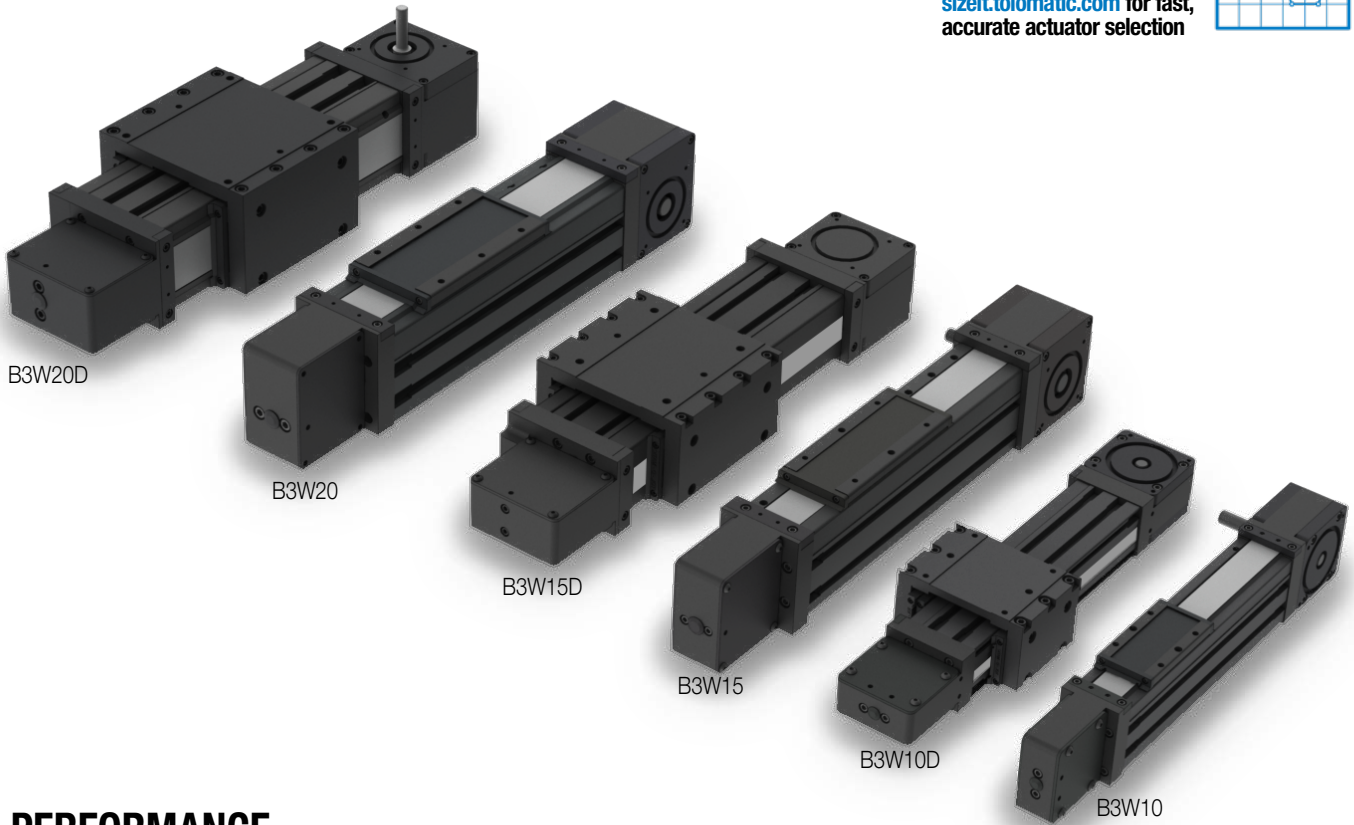
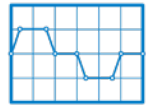

## PERFORMANCE

### CARRIER SPEED CAPABILITIES

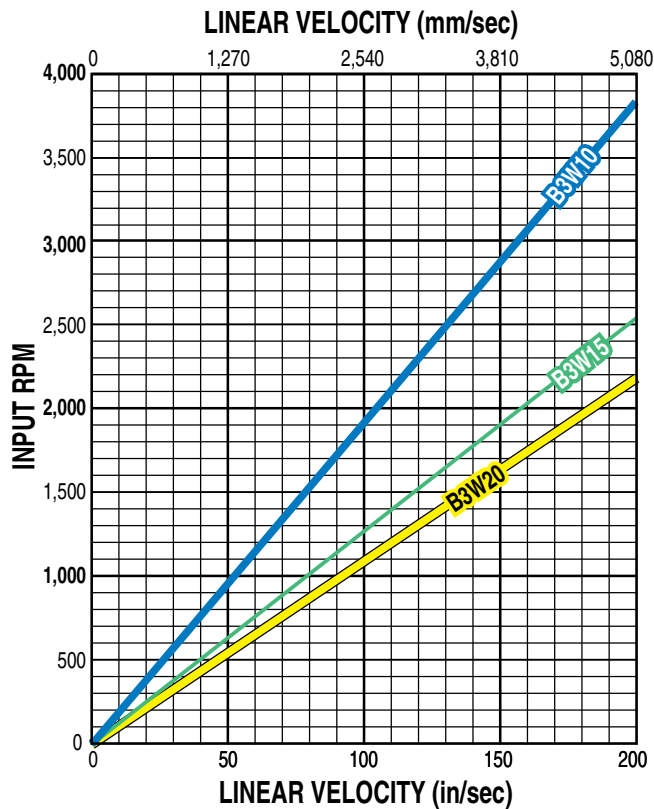

### MAXIMUM BELT THRUST

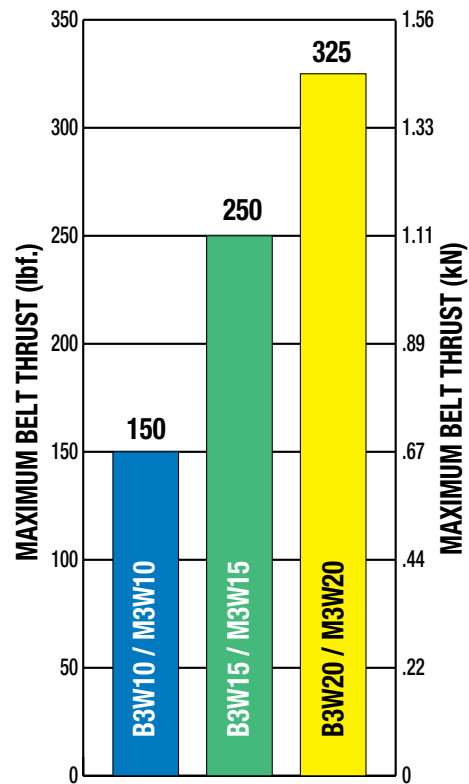

B3S

B3W

# B3W Electric Belt Drive Rodless Actuators

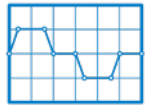

## PERFORMANCE

sizeit.tolomatic.com for fast, accurate actuator selection

### B3W STANDARD CARRIER - MAXIMUM ACCELERATION AS A FUNCTION OF LOAD WEIGHT

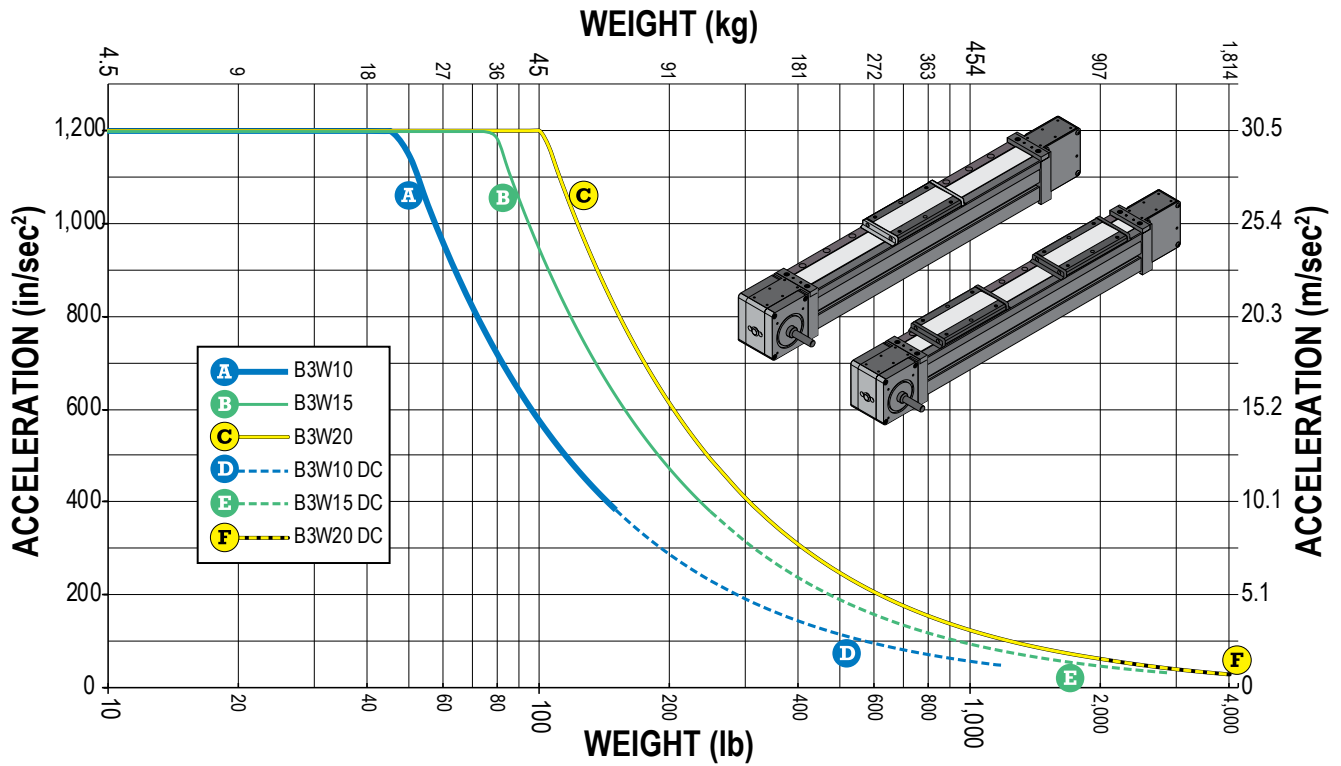

B3S

B3W

### B3W WITH DUAL 180° CARRIER - MAXIMUM ACCELERATION AS A FUNCTION OF LOAD WEIGHT

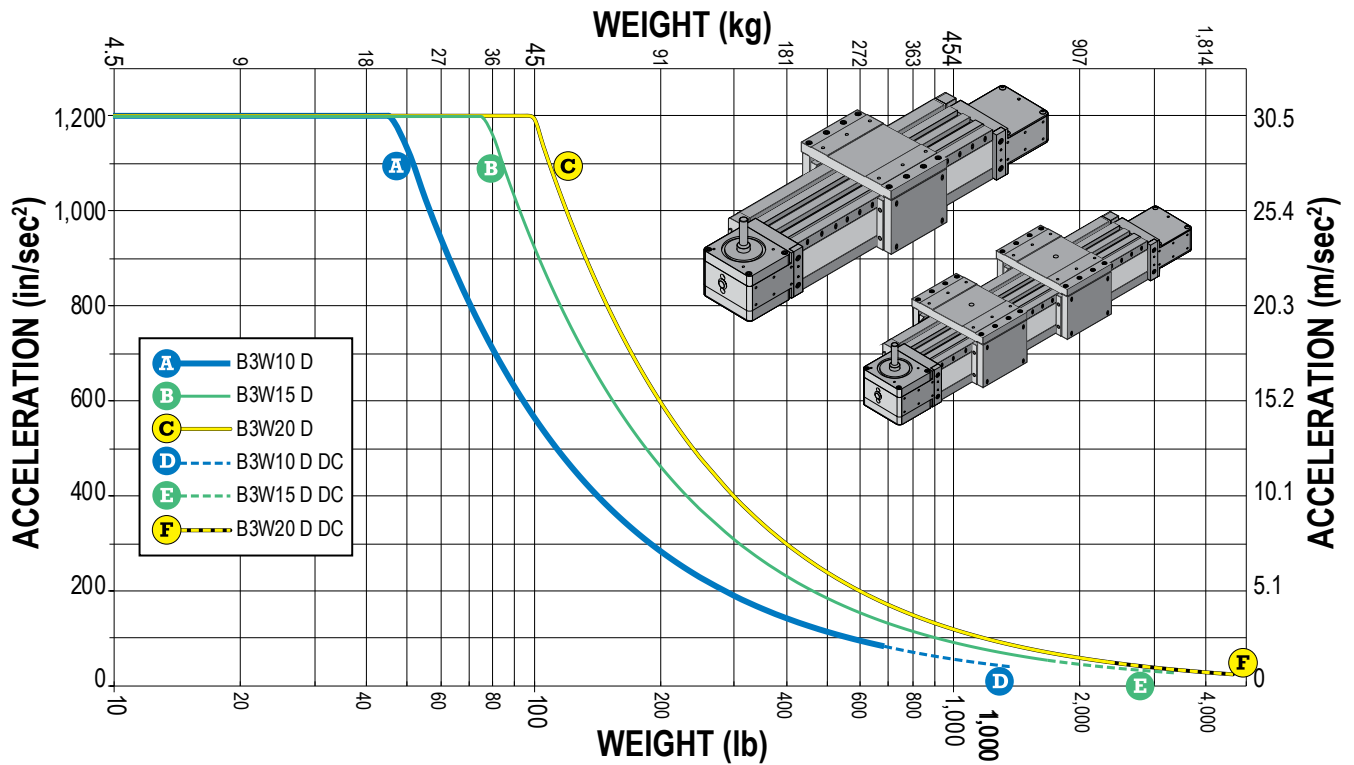

# B3W Electric Belt Drive Rodless Actuators

## SPECIFICATIONS

sizeit.tolomatic.com for fast, accurate actuator selection

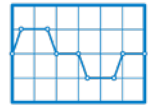

		METRIC				INCH (U.S. Conventional)			
		B3W10	B3W15	B3W20		B3W10	B3W15	B3W20	
Max. Stroke	mm	14,579	10,566	8,128	in	574	416	320	
Max. Velocity	m/sec	5.08	5.08	5.08	in/sec	200	200	200	
Max. Acceleration	m/sec <sup>2</sup>	30.48	30.48	30.48	in/sec <sup>2</sup>	1,200	1,200	1,200	
Max. Input Torque	N-m	8.5	21.2	32.2	lb-in	75.2	188.0	285.0	
Break-away Torque	Standard (single) Carrier	N-m	1.06	1.41	3.18	lb-in	9.38	12.5	28.13
	Dual 180° or Aux. Carrier	N-m	1.34	1.69	3.53	lb-in	11.88	15	31.25
	Dual 180 & Aux Carrier	N-m	1.91	2.82	5.37	lb-in	16.88	25	47.5
Pulley Pitch Dia.	mm	25.48	38.2	44.55	in	1.003	1.504	1.754	
Stroke per Rev.	mm/rev	80.04	120.02	139.95	in/rev	3.151	4.725	5.51	
Repeatability	mm	+/- 0.05	+/- 0.05	+/- 0.05	in	+/- 0.002	+/- 0.002	+/- 0.002	
Straightness & Flatness <sup>1</sup>	mm	0.017 x L*	0.017 x L*	0.017 x L*	in	0.00067 x L*	0.00067 x L*	0.00067 x L*	
Temp. Range <sup>2</sup>	°C	4 - 54	4 - 54	4 - 54	°F	40 - 130	40 - 130	40 - 130	
IP Rating <sup>3</sup>	IP	44	44	44	IP	44	44	44	
Inertia (zero stroke)	kg-cm <sup>2</sup>	0.833	4.073	7.786	lb-in <sup>2</sup>	0.2846	1.3917	2.6607	
Inertia (per unit of stroke)	kg-cm <sup>2</sup> /mm	0.00018	0.0002	0.00131	lb-in <sup>2</sup> /in	0.0016	0.0017	0.0114	
Inertia of pulley	kg-cm <sup>2</sup>	0.027	0.219	0.422	lb-in <sup>2</sup>	0.0093	0.0748	0.1441	
Inertia of carrier	kg-cm <sup>2</sup>	0.305	1.489	2.847	lb-in <sup>2</sup>	0.1041	0.5089	0.9728	
Weight of pulley	kg	0.0068	0.0244	0.047	lb	0.015	0.054	0.1036	
Weight of carrier	kg	0.39	0.71	0.97	lb	0.85	1.56	2.14	
Weight (zero stroke)	kg	3.42	11.39	16.06	lb	7.54	25.12	35.4	
Weight (per unit of stroke)	kg/mm	0.0069	0.0071	0.0128	lb/in	0.389	0.395	0.716	
		B3W10D	B3W15D	B3W20D		B3W10D	B3W15D	B3W20D	
Weight of carrier	kg	1.09	3.02	4.86	lb	2.40	6.66	10.72	
Weight (zero stroke)	kg	4.36	13.71	19.94	lb	9.62	30.22	43.97	
Weight (per unit of stroke)	g/mm	8.93	13.57	22.14	lb/in	0.50	0.76	1.24	



<sup>1</sup> The listed values relating to straightness/flatness are intended for reference purposes only, and not as an engineering standard of absolute tolerance for a given actuator. Appropriate installation is the single most important factor in reducing such deviation, so good engineering practices such as measurement, mapping, etc. must be employed in applications with stringent straightness/flatness requirements.

<sup>2</sup> Heat generated by the motor and drive should be taken into consideration as well as linear velocity and work cycle time. For applications that require operation outside of the recommended temperature range, contact the factory.

<sup>3</sup> Protected against ingress of solid particles greater than 1 mm (.039 in) and splashing water. \*L\* is maximum distance between supports - See Support Recommendations graph pg B3.9.

**LARGE FRAME MOTORS AND SMALLER SIZE ACTUATORS:** Cantilevered motors need to be supported if subjected to continuous rapid reversing duty and/or under dynamic conditions.

**NOTE:** Zero stroke inertia and weight are for an assembled actuator (including carrier, pulley and belt material) that has zero stroke length. To calculate system inertia use the formula below:

$$\text{System Inertia} = \text{Inertia}_{(\text{zero stroke})} + [\text{Inertia}_{(\text{per unit of stroke})} \times \text{number of units}]$$

(For weight calculation substitute inertia with weight in the above formula)

B3S

B3W

# B3W10 Electric Belt Drive Rodless Actuators

## DIMENSIONS Actuator & Options

3D CAD available at [www.tolomatic.com](http://www.tolomatic.com)  
Always use configured CAD solid model to determine critical dimensions

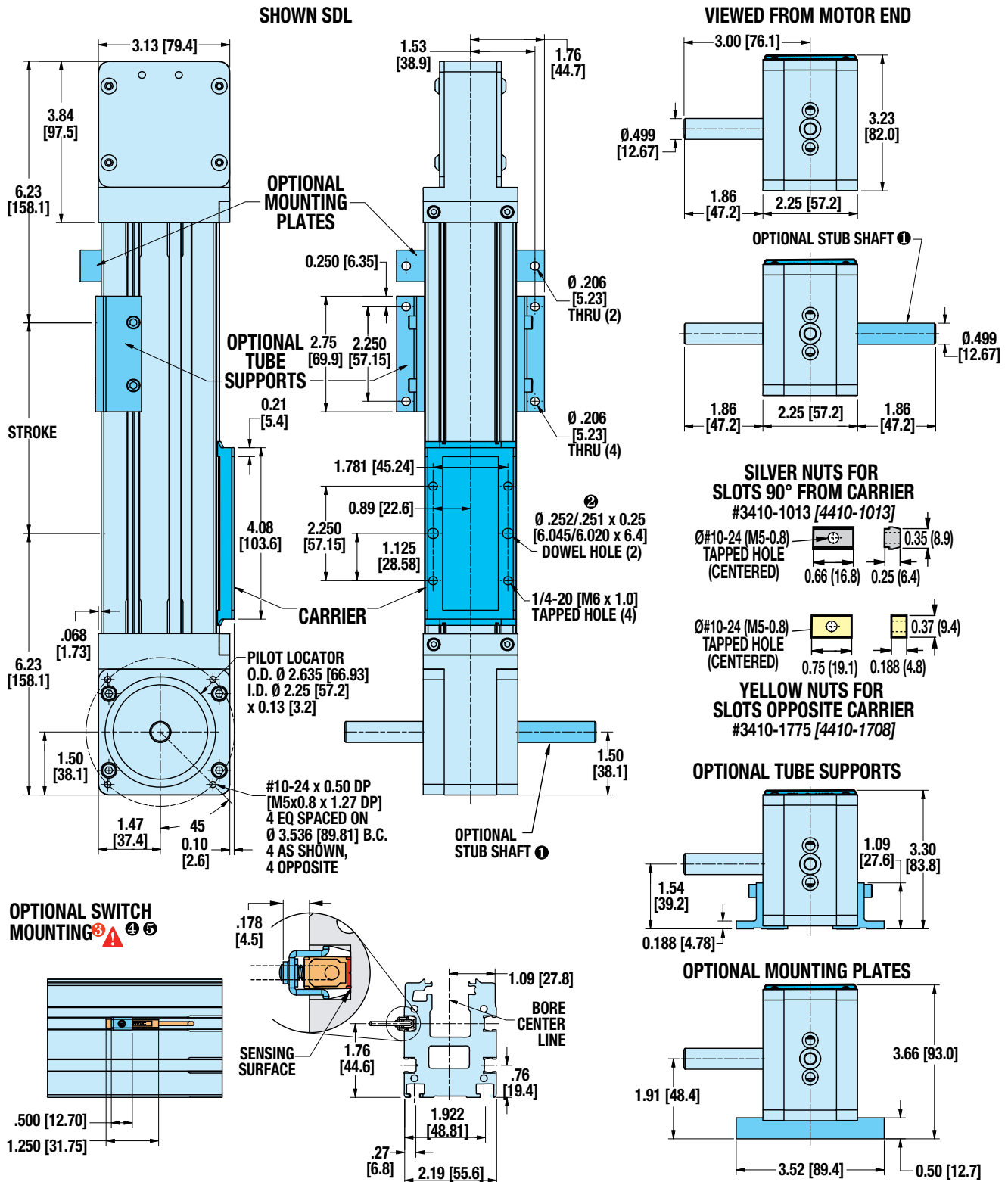

① ONE STUB SHAFT IS STANDARD ON ALL B3W ACTUATORS

⚠ **CAUTION: DO NOT OVERTIGHTEN SWITCH HARDWARE WHEN INSTALLING**

⑥ **NOTE:** Some actuators require switch mounting on a specific side of the actuator. Call Tolomatic 1-800-328-2174 for details

② **DOWEL PINS**  $\varnothing$  .003 [.08mm] (M)

④ **NOTE:** The scored face of the switch indicates the sensing surface and must face toward the magnet

Unless otherwise noted, all dimensions shown are in inches [Dimensions in brackets are in millimeters]

# B3W10 Electric Belt Drive Rodless Actuators

## DIMENSIONS Dual 180° Option

3D CAD available at [www.tolomatic.com](http://www.tolomatic.com)

Always use configured CAD solid model to determine critical dimensions

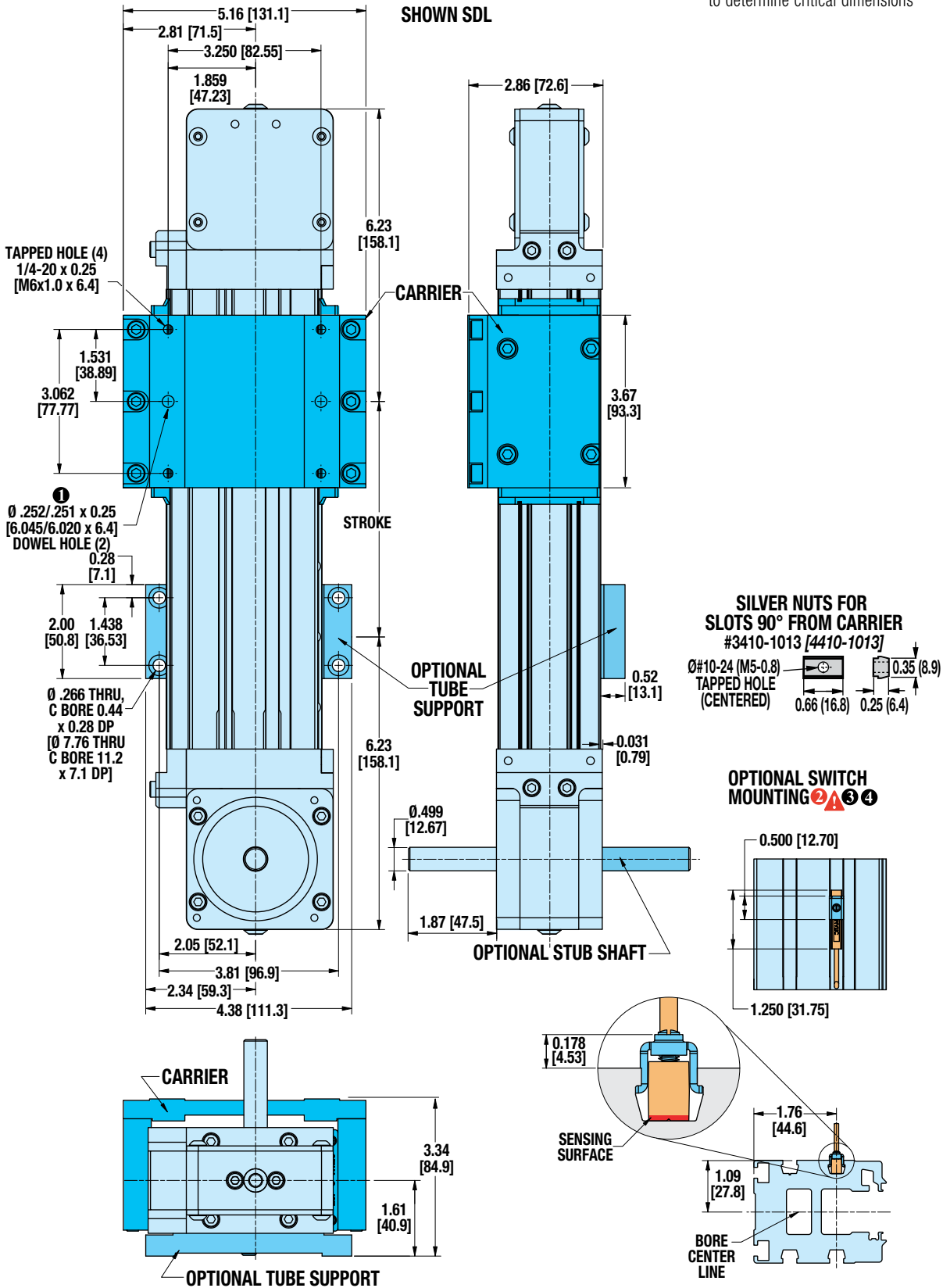

① DOWEL PINS  $\pm .003$  (.08mm)  $\text{M}$

⚠ CAUTION: DO NOT OVERTIGHTEN SWITCH HARDWARE WHEN INSTALLING

③ NOTE: The scored face of the switch indicates the sensing surface and must face toward the magnet

④ NOTE: Some actuators require switch mounting on a specific side of the actuator. Call Tolomatic 1-800-328-2174 for details

B3S

B3W

# B3W15 Electric Belt Drive Rodless Actuators

## DIMENSIONS Actuator & Options

3D CAD available at [www.tolomatic.com](http://www.tolomatic.com)  
Always use configured CAD solid model to determine critical dimensions

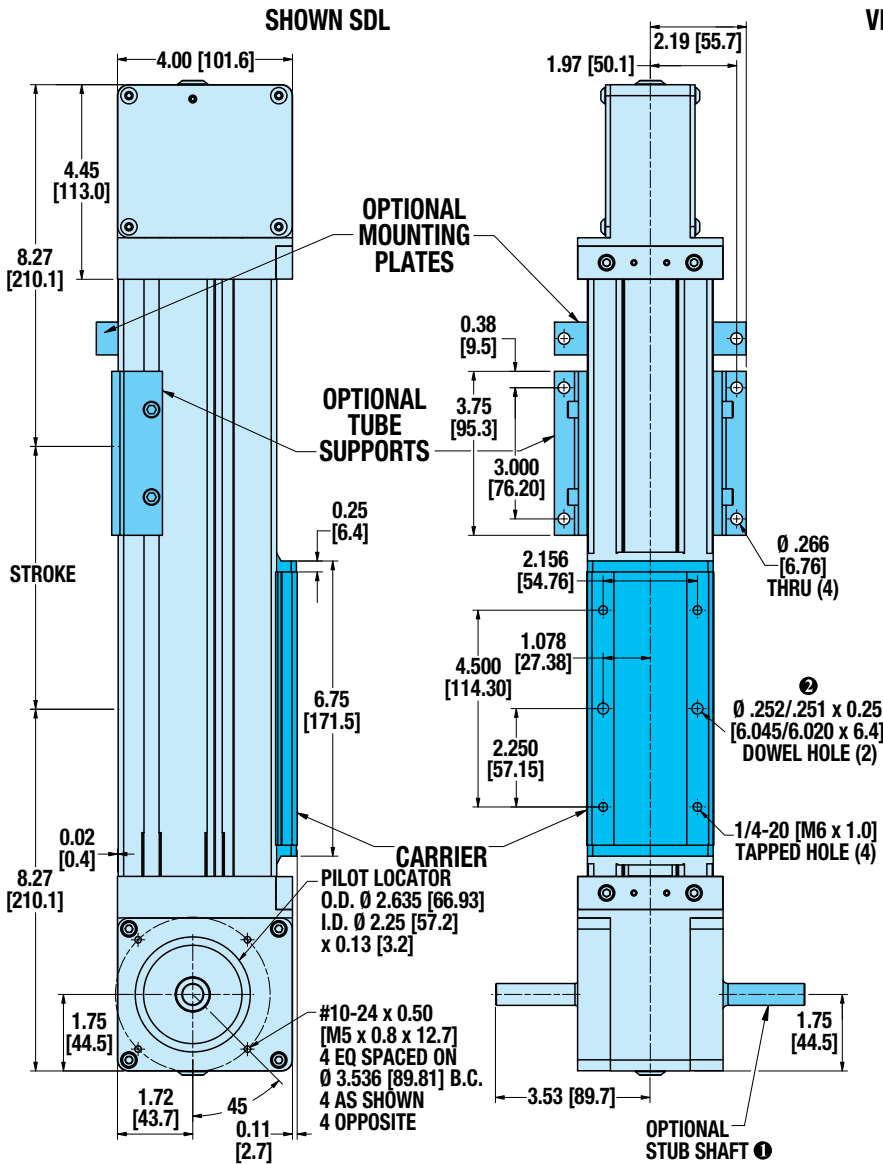

### VIEWED FROM MOTOR END

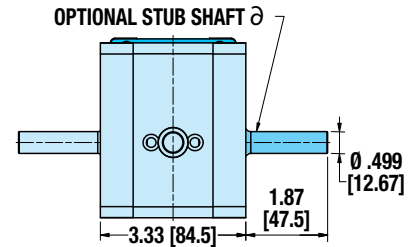
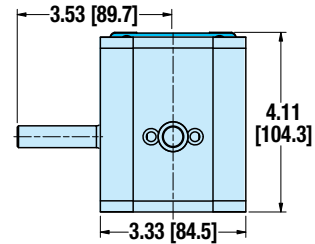

### NUTS FOR SLOTS

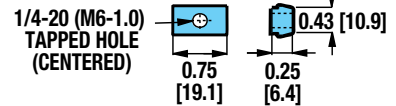

### OPTIONAL TUBE SUPPORTS

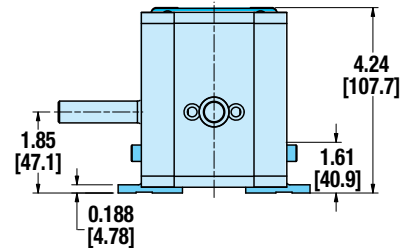

### OPTIONAL MOUNTING PLATES

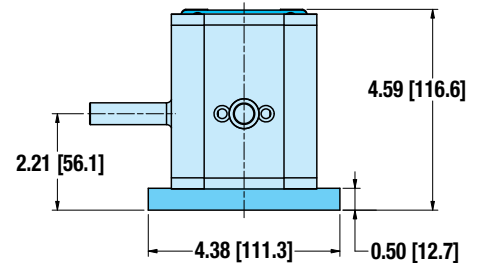

### OPTIONAL SWITCH MOUNTING ③ ④ ⑤

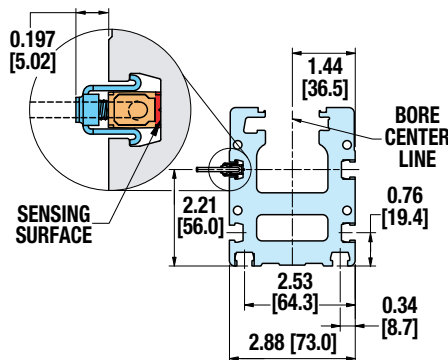
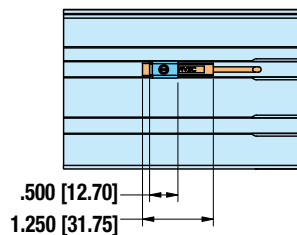

① ONE STUB SHAFT IS STANDARD ON ALL B3W ACTUATORS

③ CAUTION: DO NOT OVERTIGHTEN SWITCH HARDWARE WHEN INSTALLING

⑤ NOTE: Some actuators require switch mounting on a specific side of the actuator. Call Tolomatic 1-800-328-2174 for details

② DOWEL PINS  $\text{⊕} \text{.003} \text{ (.08mm)} \text{ (M)}$

④ NOTE: The scored face of the switch indicates the sensing surface and must face toward the magnet

Unless otherwise noted, all dimensions shown are in inches [Dimensions in brackets are in millimeters]

# B3W15 Electric Belt Drive Rodless Actuators

## DIMENSIONS Dual 180° Option

3D CAD available at [www.tolomatic.com](http://www.tolomatic.com)

Always use configured CAD solid model to determine critical dimensions

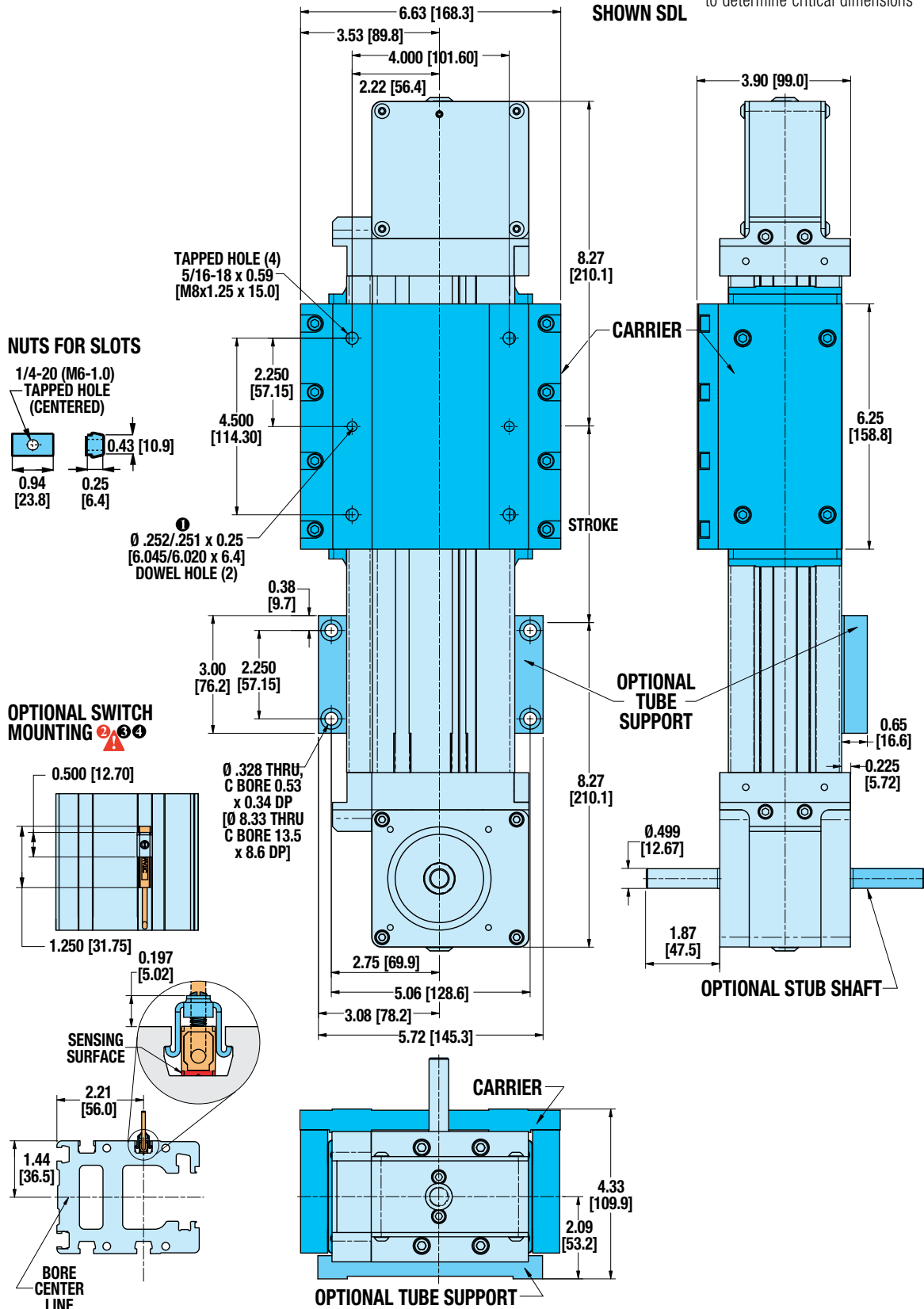

① DOWEL PINS  $\pm .003$  (.08mm) (M)

⚠ CAUTION: DO NOT OVERTIGHTEN SWITCH HARDWARE WHEN INSTALLING

② NOTE: The scored face of the switch indicates the sensing surface and must face toward the magnet

③ NOTE: Some actuators require switch mounting on a specific side of the actuator. Call Tolomatic 1-800-328-2174 for details

B3S

B3W

# B3W20 Electric Belt Drive Rodless Actuators

## DIMENSIONS Actuator & Options

3D CAD available at [www.tolomatic.com](http://www.tolomatic.com)  
Always use configured CAD solid model to determine critical dimensions

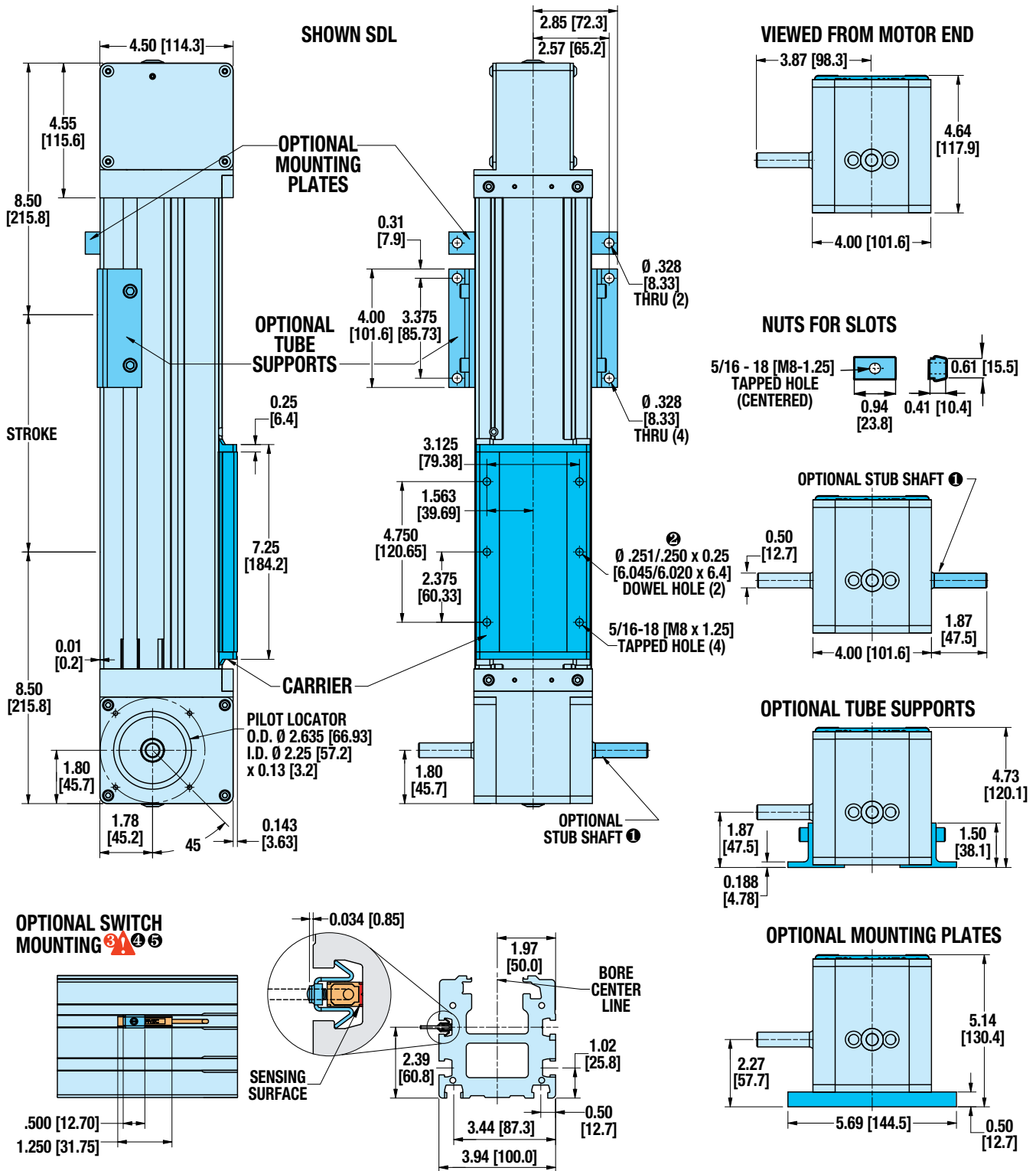

① ONE STUB SHAFT IS STANDARD ON ALL B3W ACTUATORS

③ **CAUTION: DO NOT OVERTIGHTEN SWITCH HARDWARE WHEN INSTALLING**

⑤ NOTE: Some actuators require switch mounting on a specific side of the actuator. Call Tolomatic 1-800-328-2174 for details

② DOWEL PINS  $\varnothing$  .003 (.08mm)

④ NOTE: The scored face of the switch indicates the sensing surface and must face toward the magnet

Unless otherwise noted, all dimensions shown are in inches [Dimensions in brackets are in millimeters]

# B3W20 Electric Belt Drive Rodless Actuators

## DIMENSIONS Dual 180° Option

3D CAD available at [www.tolomatic.com](http://www.tolomatic.com)

Always use configured CAD solid model to determine critical dimensions

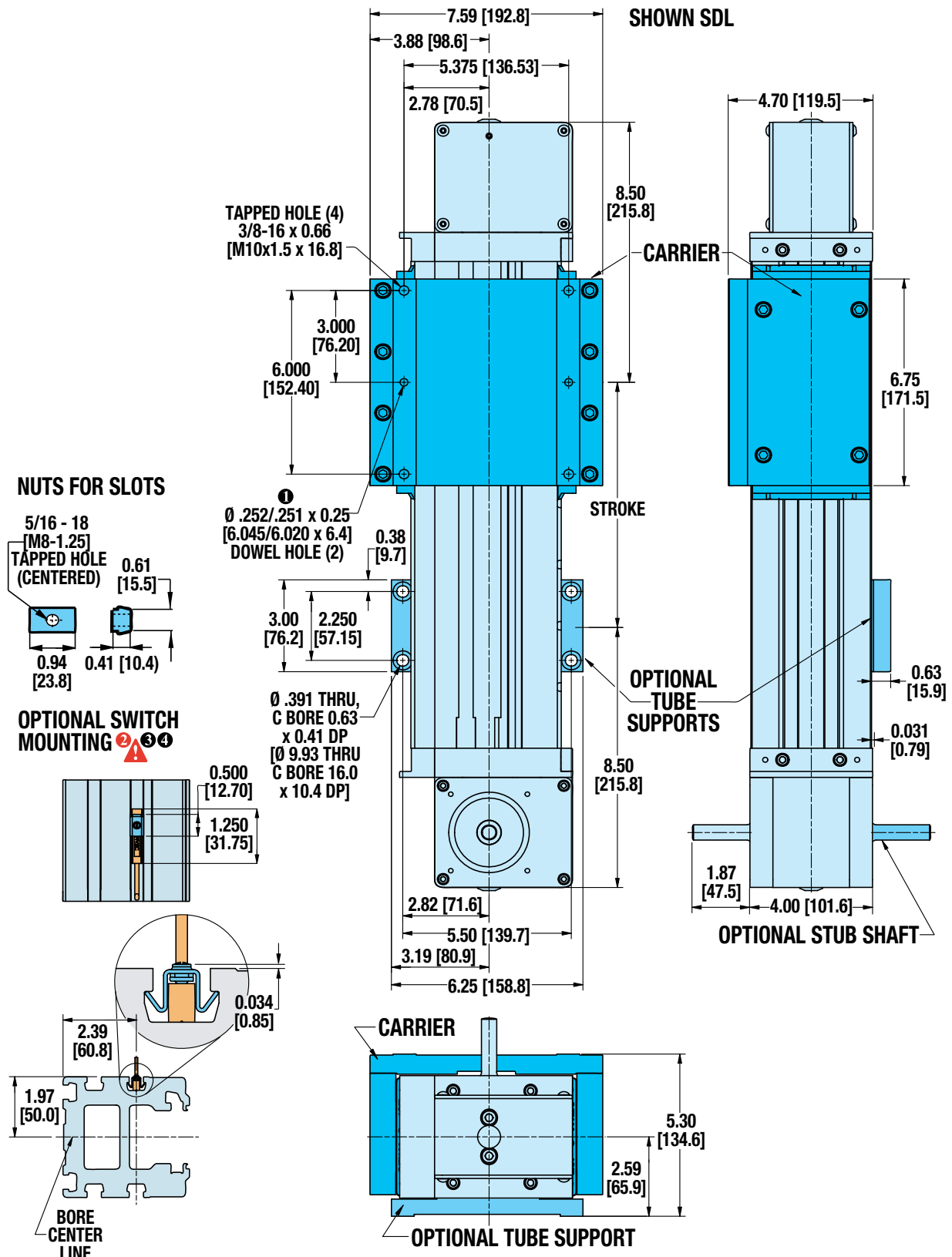

- 1 DOWEL PINS  $\pm .003$  (.08mm) M
- 2 CAUTION: DO NOT OVERTIGHTEN SWITCH HARDWARE WHEN INSTALLING
- 3 NOTE: The scored face of the switch indicates the sensing surface and must face toward the magnet
- 4 NOTE: Some actuators require switch mounting on a specific side of the actuator. Call Tolomatic 1-800-328-2174 for details

B3S

B3W

# B3W Electric Belt Drive Rodless Actuators

## MOTOR MOUNTING

3D CAD available at [www.tolomatic.com](http://www.tolomatic.com)

Always use configured CAD solid model to determine critical dimensions



### B3W DIRECT DRIVE MOTOR MOUNTING

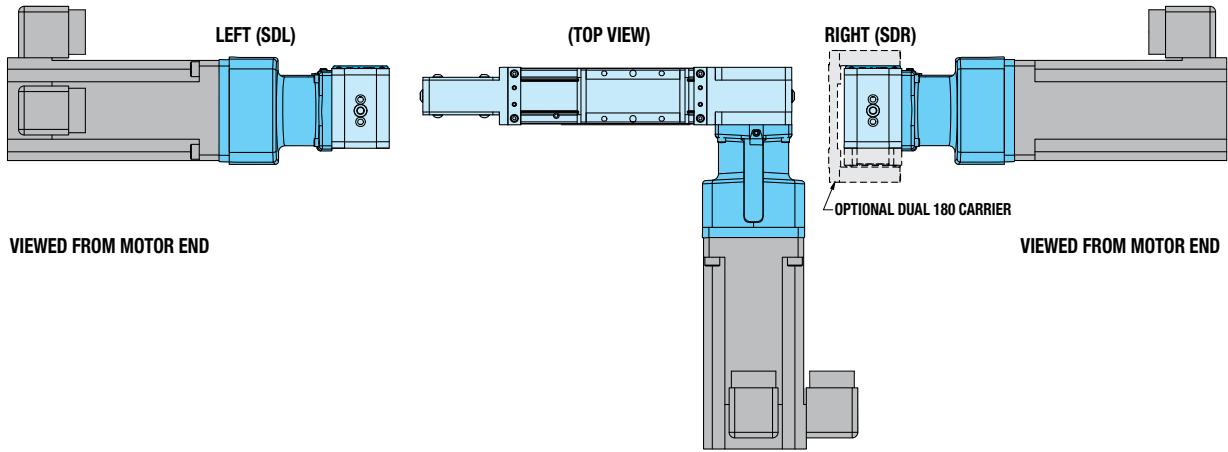

### B3W(D) REDUCTION DRIVE MOTOR MOUNTING

#### STANDARD CARRIER

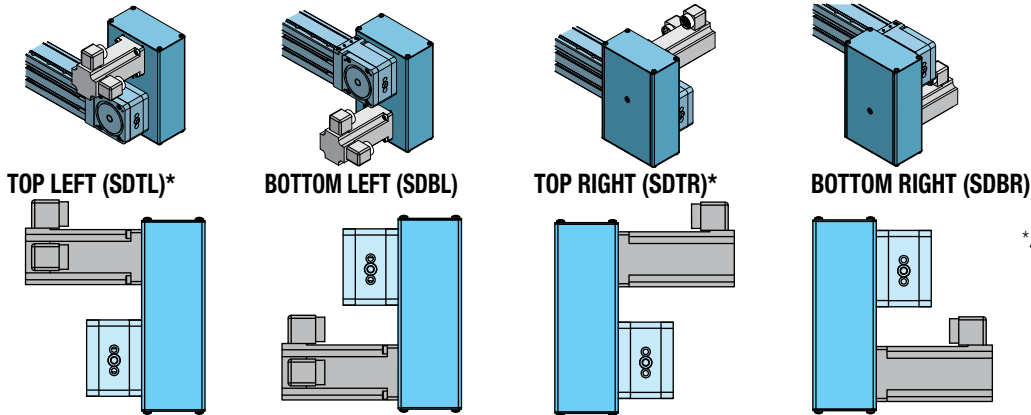

\*▲ NOTE: SDTL & SDTR are generally not recommended because the load may interfere with the motor. Stops or spacers may be required.

#### DUAL 180° CARRIER

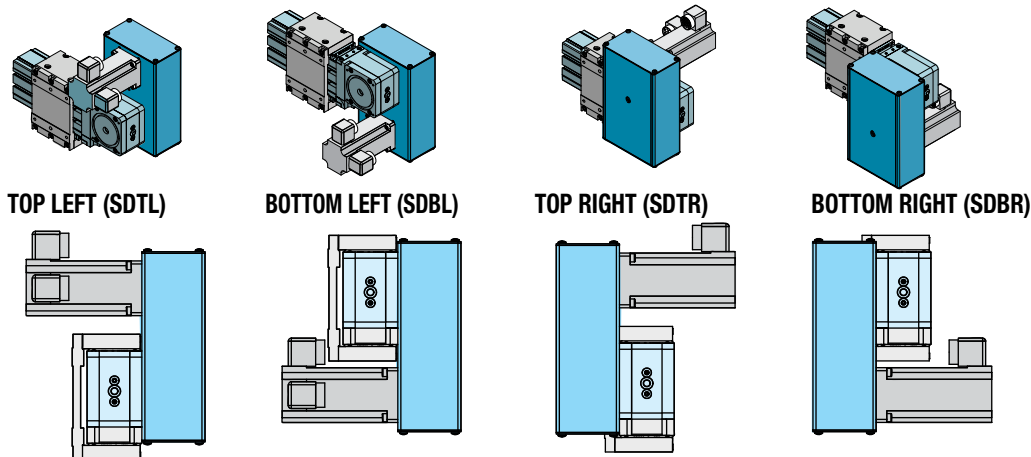

B3S

B3W

B3S

B3W

# B3S & B3W Electric Rodless Actuators

## SWITCHES

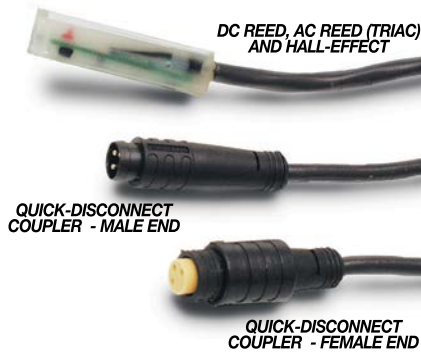

There are 10 sensing choices: DC reed, form A (open) or form C (open or closed); AC reed (Triac, open); Hall-effect, sourcing, PNP (open); Hall-effect, sinking, NPN (open); each with either flying leads or QD (quick disconnect). Commonly used to send analog signals to PLC (programmable logic controllers), TLL, CMOS circuit or other controller device. These switches are activated by the actuator's magnet.

Switches contain reverse polarity protection. QD cables are shielded; shield should be terminated at flying lead end.

If necessary to remove factory installed switches, be sure to reinstall on the same side of actuator with scored face of switch toward internal magnet.

## SPECIFICATIONS

ORDER CODE	REED DC				REED AC		HALL-EFFECT DC			
	RT	RM	BT	BM	CT	CM	TT	TM	KT	KM
LEAD	5m	QD*	5m	QD*	5m	QD*	5m	QD*	5m	QD*
CABLE SHIELDING	Unshielded	Shielded†	Unshielded	Shielded†	Unshielded	Shielded†	Unshielded	Shielded†	Unshielded	Shielded†
SWITCHING LOGIC	"A" Normally Open		"C" Normally Open or Closed		Triac Normally Open		PNP (Sourcing) Normally Open		NPN (Sinking) Normally Open	
MECHANICAL CONTACTS	Single-Pole Single-Throw		Single-Pole Double-Throw		Single-Pole Single-Throw		NO, These Are Solid State Components			
COIL DIRECT	Yes		Yes		Yes		—			
POWER LED	None		None		None		None		None	
SIGNAL LED	Red		None		None		Red		Red	
OPERATING VOLTAGE	200 Vdc max.		120 Vdc max.		120 Vac max.		5 - 25 Vdc			
OUTPUT RATING	—		—		—		25 Vdc, 200mA dc			
OPERATING TIME	0.6 msec max. (including bounce)		0.7 msec max. (including bounce)		—		< 10 micro sec.			
OPERATING TEMPERATURE	-40°F [-40°C] to 158°F [70°C]						0°F [-18°C] to 150°F [66°C]			
RELEASE TIME	1.0 msec. max.		—		—		—			
ON TRIP POINT	—		—		—		150 Gauss maximum			
OFF TRIP POINT	—		—		—		40 Gauss minimum			
**POWER RATING (WATTS)	10.0 §		3.0 §§		10.0		5.0			
VOLTAGE DROP	2.6 V typical at 100 mA		NA		—		—			
RESISTANCE	0.1 Ω Initial (Max.)		—		—		—			
CURRENT CONSUMPTION	—		—		1 Amp at 86°F [30°C]   0.5 Amp at 140°F [60°C]		200 mA at 25 Vdc			
FREQUENCY	—		—		47 - 63 Hz		—			
CABLE MIN. BEND RADIUS	STATIC		0.630" [16mm]							
	DYNAMIC		Not Recommended							

**⚠ CAUTION: DO NOT OVER TIGHTEN SWITCH HARDWARE WHEN INSTALLING!**

**⚠ \*\* WARNING:** Do not exceed power rating (Watt = Voltage X Amperage). Permanent damage to sensor will occur.

\*QD = Quick Disconnect; Male coupler is located 6" [152mm] from sensor, Female coupler to flying lead distance is 197" [5m] also see Cable Shielding specification above

**⚠ REPLACEMENT OF QD SWITCHES MANUFACTURED BEFORE JULY 1, 1997:** It will be necessary to replace or rewire the female end coupler.

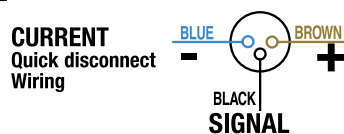

**Reed Switch Life Expectancy:** Up to 200,000,000 cycles (depending on load current, duty cycle and environmental conditions)

†Shielded from the female quick disconnect coupler to the flying leads. Shield should be terminated at flying lead end.

§ Maximum current 500mA (not to exceed 10VA) Refer to Temperature vs. Current graph and Voltage Derating graph

B3S

B3W

# B3S & B3W Electric Rodless Actuators

## SWITCH PERFORMANCE

### PERFORMANCE

TEMP. vs CURRENT, DC REED

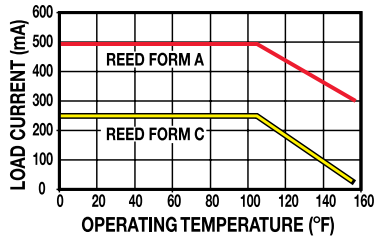

TEMP. vs CURRENT, AC REED

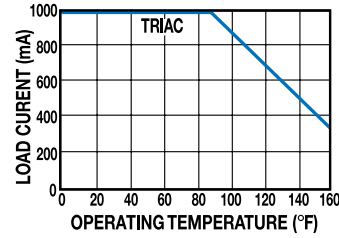

VOLTAGE DERATING, DC REED

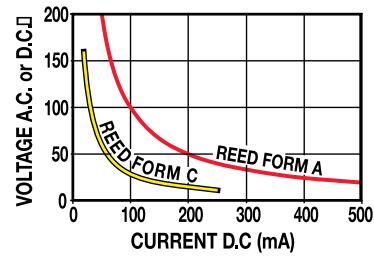

### WIRING DIAGRAMS

**R**T & **R**M DC REED, FORM A

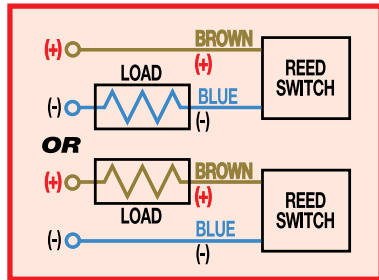

**C**T & **C**M AC REED, TRIAC

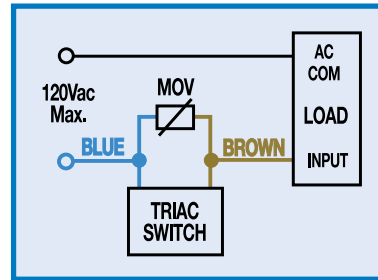

### INSTALLATION INFORMATION



**⚠** THE NOTCHED FACE OF THE SWITCH INDICATES THE SENSING SURFACE AND MUST FACE TOWARD THE MAGNET.

**B**T & **B**M DC REED, FORM C

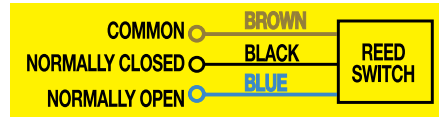

**⚠** THE NOTCHED GROOVE IN THE ACTUATOR INDICATES THE GROOVE TO INSTALL THE SWITCH. CONTACT TOLOMATIC IF SWITCHES ARE REQUIRED ON ANOTHER SIDE OF ACTUATOR.

**T**T & **T**M HALL-EFFECT, SOURCING, PNP

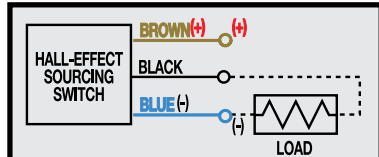

**K**T & **K**M HALL-EFFECT, SINKING, NPN

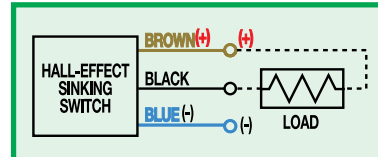

B3S

B3W

# Electric Rodless Actuator Application Worksheet

USE THE TOLOMATIC SIZING AND SELECTION SOFTWARE AVAILABLE ON-LINE AT [www.tolomatic.com](http://www.tolomatic.com)

or call Tolomatic at 1-800-328-2174. We will provide any assistance needed to determine the proper actuator for the job.

## ACTUATOR ORIENTATION

Horizontal Carrier (Up)

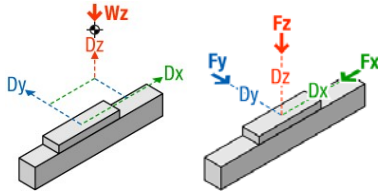

Vertical-Motor End Up

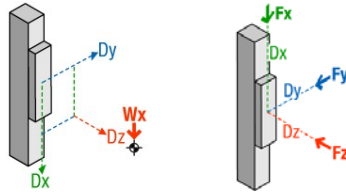

Horizontal Carrier (Down)

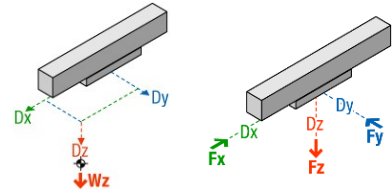

Angled Carrier

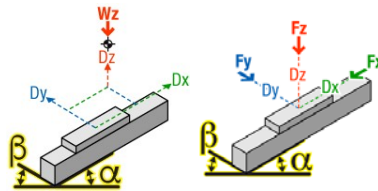

Vertical-Motor End Down

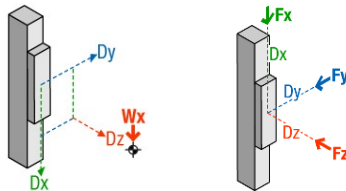

Side Carrier Plate

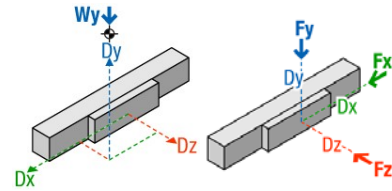

$\alpha$  angle: \_\_\_\_\_ degrees  
 $\beta$  angle: \_\_\_\_\_ degrees

## ACTUATOR REQUIREMENTS

Stroke length: \_\_\_\_\_  inches  millimeters

No. of Cycles: \_\_\_\_\_  per minute  per hour

Actuator to Hold Position:  required  not required

If Hold Required:  after move  during power loss

Motor:  Third Party Motor  Tolomatic Motor

## APPLICATION ENVIRONMENT

Ambient Temperature: \_\_\_\_\_  °F  °C

Actuator Environment Description and Ingress Protection Requirements:

## MOTION & FORCES

### Extend

Move Distance: \_\_\_\_\_  in  mm

Move Time: \_\_\_\_\_ seconds

Max. Speed: \_\_\_\_\_  in/s  mm/s

Dwell Time After Move: \_\_\_\_\_ seconds

### Load

Load: \_\_\_\_\_  lb  kg

Supported by Actuator: \_\_\_\_\_ %

Center of Load:

$D_x$ : \_\_\_\_\_  in  mm

$D_y$ : \_\_\_\_\_  in  mm

$D_z$ : \_\_\_\_\_  in  mm

Assign to Moves:  Extend  Retract

### Retract

Move Distance: \_\_\_\_\_  in  mm

Move Time: \_\_\_\_\_ seconds

Max. Speed: \_\_\_\_\_  in/s  mm/s

Dwell Time After Move: \_\_\_\_\_ seconds

### Force

Force: \_\_\_\_\_  lbf  N

Force Direction:  Toward  Away

Direction of Applied Force:   $F_x$    $F_y$    $F_z$

Center of Applied Force:

$D_x$ : \_\_\_\_\_  in  mm

$D_y$ : \_\_\_\_\_  in  mm

$D_z$ : \_\_\_\_\_  in  mm

Assign to Moves:  Extend  Retract



# SELECTION GUIDELINES

The process of selecting a load bearing actuator for a given application can be complex. It is highly recommended that you contact Tolomatic or a Tolomatic Distributor for assistance in selecting the best actuator for your application. The following overview of the selection guidelines are for educational purposes only.

## 1 CHOOSE ACTUATOR SIZE

Choose an actuator that has the (A) thrust, (B) speed and (C) moment load capacity to move the load. **A.**

Max Thrust: B3S see page B3\_11;

B3W see page B3\_25

**B.** Max. Speed: B3S see critical speed graphs page B3\_13 to B3\_15; All B3W

sizes = 200 in/sec (5m/sec).

**C.** Moment & Load B3S & B3W see page B3\_8

## 2 COMPARE LOAD TO MAXIMUM LOAD CAPACITIES

Calculate the application load (combination of load mass and forces applied to the carrier) and application bending moments (sum of all moments  $M_x$ ,  $M_y$ , and  $M_z$  applied to the carrier). Be sure to evaluate the magnitude of dynamic inertia moments. When a rigidly attached load mass is accelerated or decelerated, its inertia induces bending moments on the carrier. Careful attention to how the load is decelerated at the end of the stroke is required for extended ac-

tuator performance and application safety. If either load or any of your moments exceed figures indicated in the Moment and Load Capacity table (page B3\_8) for the actuator consider:

- 1) Higher capacity bearing style
- 2) A larger actuator size
- 3) Auxiliary carrier
- 4) External guide system

## 3 CALCULATE LOAD FACTOR LF

For loads with a center of gravity offset from the carrier account for both applied (static) and dynamic loads. The load factor (LF) must not exceed the value of 1.5.

$$L_f = \frac{M_x}{M_{x_{max}}} + \frac{M_y}{M_{y_{max}}} + \frac{M_z}{M_{z_{max}}} + \frac{F_y}{F_{y_{max}}} + \frac{F_z}{F_{z_{max}}} \leq 1.5$$

If  $L_f$  does exceed the value of 1.5, consider the four choices listed in step #2.

## 4 ESTABLISH YOUR MOTION PROFILE AND CALCULATE ACCELERATION RATE

Using the application stroke length and maximum carrier velocity (or time to complete the linear motion), establish the motion profile. Select either triangular (accel-decel) or trapezoidal (accel-constant speed-decel) profile. Now calculate the maximum acceleration and deceleration rates of the move.

**For the B3S** Acceleration/deceleration should not exceed critical speed (page B3\_13) for the screw/nut combination chosen. **For the B3W** acceleration/deceleration should not exceed 1200 in/sec<sup>2</sup> (30.48 m/sec<sup>2</sup>). Also, do not exceed safe rates of dynamic inertia moments determined in step #3.

## 5 SELECT THE LEAD SCREW (B3S ONLY)

Based on the application requirements for accuracy, backlash, quiet operation, life, etc. select the appropriate lead screw type (Acme screw with a solid nut or ball screw with a standard or anti-backlash nut) and the pitch (lead). For additional information on screw selection, consult "Which Screw? Picking the Right Technology" (#9900-4644) available at [www.tolomatic.com](http://www.tolomatic.com).



## 6 SELECT MOTOR (GEARHEAD IF NECESSARY) AND DRIVE

To help select a motor and drive, use the sizing equations located in the Engineering Resources section [ENGR\_] of the Tolomatic Electric Products Catalog (#3600-4609) to calculate the application thrust and torque requirements. Refer to Motor sections to determine the motor and drive.

## 7 DETERMINE TUBE SUPPORT/ MOUNTING PLATE/ T-NUT REQUIREMENTS

- Consult the Tube Support Requirements graph for the model selected (page B3\_9)
- Cross reference the application load and maximum distance between supports
- Select the appropriate number of tube supports, T-nuts or mounting plates and requirements for motor and adapter clearance.

## 8 CONSIDER OPTIONS

- Choose metric or inch (US Conventional) load mounting. (When ordering use  for inch or  for metric)
- Switches - Reed, Solid State PNP or NPN, all available normally open or normally closed.

## 9 CONSIDER ORIENTATION (B3W ONLY)

Belt drives used in vertical applications will not prevent a load falling in the event of a timing belt failure. A secondary safety measure is recommended if a B3W is used in a safety critical vertical application.

Use the Tolomatic Sizing & Selection Software or call Tolomatic at 1-800-328-2174

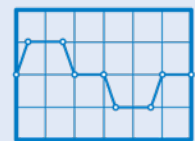

[sizeit.tolomatic.com](http://sizeit.tolomatic.com)  
for fast, accurate  
actuator selection



[tolomatic.com/ask](http://tolomatic.com/ask)  
Technical support  
before and after  
purchase

# B3S Electric Screw Drive Rodless Actuators



## ORDERING

### BASE MODEL

**B3S 20 D BNL02 SK36 LMI**

#### MODEL TYPE

**B3S** B3S Screw Drive Rodless Actuator

#### SIZE

**10, 15, 20**

#### DUAL 180° CARRIER

**D** Dual 180° Carrier

#### NUT/SCREW CONFIGURATION

INCH MODELS (US Conventional)	METRIC MODELS†
<b>SOLID NUT / PITCH (turn/in)</b> ∅SN01 ∅SN02, SNA02 SN05 ∅SN (Solid Nut) not available for 20 Size	<b>SOLID NUT / LEAD (mm/turn)</b> ∅SN12
<b>BALL NUT / PITCH (turn/in)</b> BN02, BNL02 BN05, BNL05 BN08, BNL08	<b>BALL NUT / LEAD (turn/in)</b> BNM10 BN05, BNL05 BN08, BNL08

† The metric version provides metric tapped holes for mounting of the load to the carrier and of the actuator to mounting surfaces

#### STROKE LENGTH & MOUNTING TYPE

**SK** \_\_\_\_\_ Stroke, enter desired stroke length in **inches**

**SM**† \_\_\_\_\_ Stroke, enter desired stroke length in **millimeters**

**NOTE:** Actuator mounting threads and mounting fasteners will be either inch or metric; depending on how stroke length is indicated

**SK**=inch mounting

**SM**= metric mounting

**⚠ Not all codes listed are compatible with all options.**

Use Tolomatic Sizing Software to determine available options and accessories based on your application requirements.

### OPTIONS

**DC18 TS2 BM2 TN8**

#### MOTOR MOUNTING / REDUCTIONS

(must choose one)

**LMI** In-Line mounting

**LME23** Ext. shaft for RP & 23 frame motor

**LME34** Ext. shaft for RP & 34 frame motor

**\*LMX** Extended shaft - old style (see note)

**\*For replacement actuators with extended motor shafts purchased prior to 6/24/02, use the LMX configuration code.**

**⚠ A motor size and code must be selected when specifying a reverse-parallel mounting configuration.**

**RPL1** 1:1 Reverse-Parallel mount left

**RPR1** 1:1 Reverse-Parallel mount right

**RPB1** 1:1 Reverse-Parallel mount bottom

**RPT1** 1:1 Reverse-Parallel mount top

**RPL2** 2:1 Reverse-Parallel mount left

**RPR2** 2:1 Reverse-Parallel mount right

**RPB2** 2:1 Reverse-Parallel mount bottom

**RPT2** 2:1 Reverse-Parallel mount top

#### AUXILIARY CARRIER

**DC** \_\_\_\_\_ Auxiliary Carrier, then center-to-center spacing desired in inches (**SK**) or millimeters (**SM**).

(Same unit of measure as stroke length is required)  
Center-to-center spacing between carriers adds to overall length of the actuator, this distance will not be subtracted from stroke length specified in the previous step.

#### SUPPORTS AND MOUNTING PLATES

(both may be selected)

**TS** \_\_\_\_\_ Tube Supports plus quantity desired

**\*\*MP** \_\_\_\_\_ Mounting Plates plus quantity desired

**\*\*Mounting plates are not available on B3SD Dual 180° models.**

#### SWITCHES

(Quantity desired follows product code)

**RM** \_\_\_\_\_ Reed Switch (Form A) with 5-meter lead/QD (Quick-disconnect)

**RT** \_\_\_\_\_ Reed Switch (Form A) with 5-m lead

**BM** \_\_\_\_\_ Reed Switch (Form C) with 5-meter lead/QD

**BT** \_\_\_\_\_ Reed Switch (Form C) with 5-m lead

**KM** \_\_\_\_\_ Hall-effect Sinking Switch with 5-meter lead/QD

**KT** \_\_\_\_\_ Hall-effect Sinking Switch w/ 5-m lead

**TM** \_\_\_\_\_ Hall-effect Sourcing Switch with 5-meter lead/QD

**TT** \_\_\_\_\_ Hall-effect Sourcing Switch with 5-meter lead

**CM** \_\_\_\_\_ TRIAC Switch with 5-meter lead/QD

**CT** \_\_\_\_\_ TRIAC Switch with 5-meter lead

#### T-NUTS

**TN** \_\_\_\_\_ Additional T-Nuts and quantity

#### FOOD GRADE LUBRICATION

**LUB** \_\_\_\_\_ Grease, Food/Drug

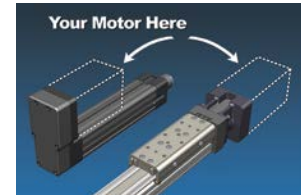

**"YOUR MOTOR HERE." MADE-TO-ORDER MOTOR MOUNTS. FAST DELIVERY.**

• Select a high-performance Tolomatic electric actuator and we'll provide a motor-specific interface for your motor. With our online database, you can select from over 60 motor manufacturers and hundreds of models.

Visit [www.tolomatic.com/ymh](http://www.tolomatic.com/ymh) to find your motor/actuator match!

NOTE: Brakes mounted on reduction drives (especially in vertically positioned actuators) will not prevent back driving of the screw and the load falling under gravity in the event of a timing belt failure. An inline motor mount with a fail-safe brake mounted directly to the actuator shaft or a special geared or thru-shaft reduction drive construction should be considered if a brake is required in a safety critical application. Contact Tolomatic for alternative reduction drive brake mounting options.

Gearheads may be used with reduction drives. However, the torque on the belt and internal reduction drive components must remain below the capabilities of the assembly to prevent belt slipping or premature failure. Contact Tolomatic for additional information if required.

#### FIELD RETROFIT KITS

ITEM	B3S10_SM	B3S15_SM	B3S20_SM	B3S10_SK	B3S15_SK	B3S20_SK
Tube Supports	4410-9006	4415-9006	4420-9006	3410-9006	3415-9006	3420-9006
Tube Supports (B3SD Dual 180° models)	4410-9026	4415-9026	4420-9026	3410-9026	3415-9026	3420-9026
1/2" Mounting Plates	4410-9030	4415-9030	4420-9030	3410-9142	3415-9056	3420-9056
1" Mounting Plates	4410-9031	4415-9031	—	3410-9057	3415-9057	—

# B3W Electric Belt Drive Rodless Actuators



## ORDERING

### BASE MODEL

**B3W20DBWS40SK56SDTR**

### OPTIONS

**DC18TS2BM2TN16**

**MODEL TYPE**  
B3W B3W Series Belt Drive

**SIZE**  
10, 15, 20

**DUAL 180° CARRIER**  
D Dual 180° Carrier

**BELT MATERIAL AND WIDTH**  
BWS18 18mm Polyurethane Steel belt (B3W10)  
BWS30 30mm Polyurethane Steel belt (B3W15)  
BWS40 40mm Polyurethane Steel belt (B3W20)

**STROKE LENGTH & MOUNTING TYPE**  
SK \_\_\_\_\_ Stroke, enter desired stroke length in **inches**  
SM† \_\_\_\_\_ Stroke, enter desired stroke length in **millimeters**  
**NOTE:** Actuator mounting threads and mounting fasteners will be either inch or metric; depending on how stroke length is indicated  
SK=inch mounting  
SM=metric mounting

† The metric version provides metric tapped holes for mounting of the load to the carrier and of the actuator to mounting surfaces

**!** Not all codes listed are compatible with all options.

Use Tolomatic Sizing Software to determine available options and accessories based on your application requirements.

**MOTOR MOUNTING / REDUCTIONS**  
(must choose one)  
SDL, SDLB\* Direct Drive on left  
SDR, SDRB\* Direct Drive on right  
**!** A motor size and code must be selected when specifying a 3:1 reduction.  
SDTL, SDTLB\* 3:1 Reduction on top left  
SDTR, SDTRB\* 3:1 Reduction on top right  
SDBL, SDBLB\* 3:1 Reduction on bottom left  
SDBR, SDBRB\* 3:1 Reduction on bottom right  
\* For Dual Stub Shaft option

**AUXILIARY CARRIER**  
DC\_ \_Auxiliary Carrier, then center-to-center spacing desired in inches (SK) or millimeters (SM).  
(Same unit of measure as stroke length is required)  
Center-to-center spacing between carriers adds to overall length of the actuator, this distance will not be subtracted from stroke length specified in the previous step.

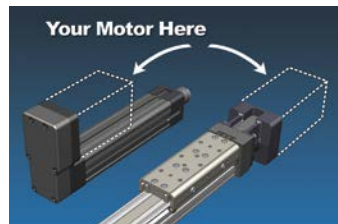

**"YOUR MOTOR HERE." MADE-TO-ORDER MOTOR MOUNTS. FAST DELIVERY.**

• Select a high-performance Tolomatic electric actuator and we'll provide a motor-specific interface for your motor. With our online database, you can select from over 60 motor manufacturers and hundreds of models.

Visit [www.tolomatic.com/yhm](http://www.tolomatic.com/yhm) to find your motor/actuator match!

**SUPPORTS AND MOUNTING PLATES**  
(both may be selected)  
TS\_ Tube Supports, enter quantity desired  
MP\_ Mounting Plates, enter quantity desired

**SWITCHES**

CODE	TYPE	QUICK-DISCONNECT	LEAD LENGTH	QUANTITY
RM	REED	Form A	QD	5 meters After code enter quantity desired
RT			no	
BM		Form C	QD	
BT			no	
KM	HALL-EFFECT	Sinking	QD	
KT			no	
TM		Sourcing	QD	
TT			no	
CM	TRIAC		QD	
CT			no	

**T-NUTS**  
TN\_ Additional T-Nuts, enter quantity

NOTE: Brakes mounted on reduction drives (especially in vertically positioned actuators) will not prevent back driving of the screw and the load falling under gravity in the event of a timing belt failure. An inline motor mount with a fail-safe brake mounted directly to the actuator shaft or a special geared or thru-shaft reduction drive construction should be considered if a brake is required in a safety critical application. Contact Tolomatic for alternative reduction drive brake mounting options.

Gearheads may be used with reduction drives. However, the torque on the belt and internal reduction drive components must remain below the capabilities of the assembly to prevent belt slipping or premature failure. Contact Tolomatic for additional information if required.

**FIELD RETROFIT KITS**

ITEM	B3W10_SM	B3W15_SM	B3W20_SM	B3W10_SK	B3W15_SK	B3W20_SK
Tube Supports	4410-9006	4415-9006	4420-9006	3410-9006	3415-9006	3420-9006
Tube Supports (B3WD Dual 180° models)	4410-9170	4415-9170	4420-9170	3410-9170	3415-9170	3420-9170
1/2" Mounting Plates (MRV 23-frame motors)	4410-9030	4415-9030	—	3410-9056	3415-9056	—
1/2" Mounting Plates (MRV all frame motors)	—	—	4420-9030	—	—	3420-9056
1" Mounting Plates (MRV all frame motors)	4410-9031	—	—	3410-9057	—	—
1" Mounting Plates (MRV 34-frame motors)	—	4415-9031	—	—	3415-9057	—

# The Tolomatic Difference Expect More From the Industry Leader:



## INNOVATIVE PRODUCTS

Solutions with Endurance Technology<sup>SM</sup> for challenging applications.



## FAST DELIVERY

Built-to-order with configurable stroke lengths and flexible mounting options.

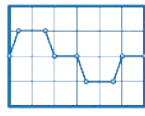

## ACTUATOR SIZING

Size and select electric actuators with our online software.



## YOUR MOTOR HERE<sup>®</sup>

Match your motor to compatible mounting plates with Tolomatic actuators.



## CAD LIBRARY

Download 2D or 3D CAD files for Tolomatic products.



## TECHNICAL SUPPORT

Get a question answered or request a virtual design consultation with one of our engineers.

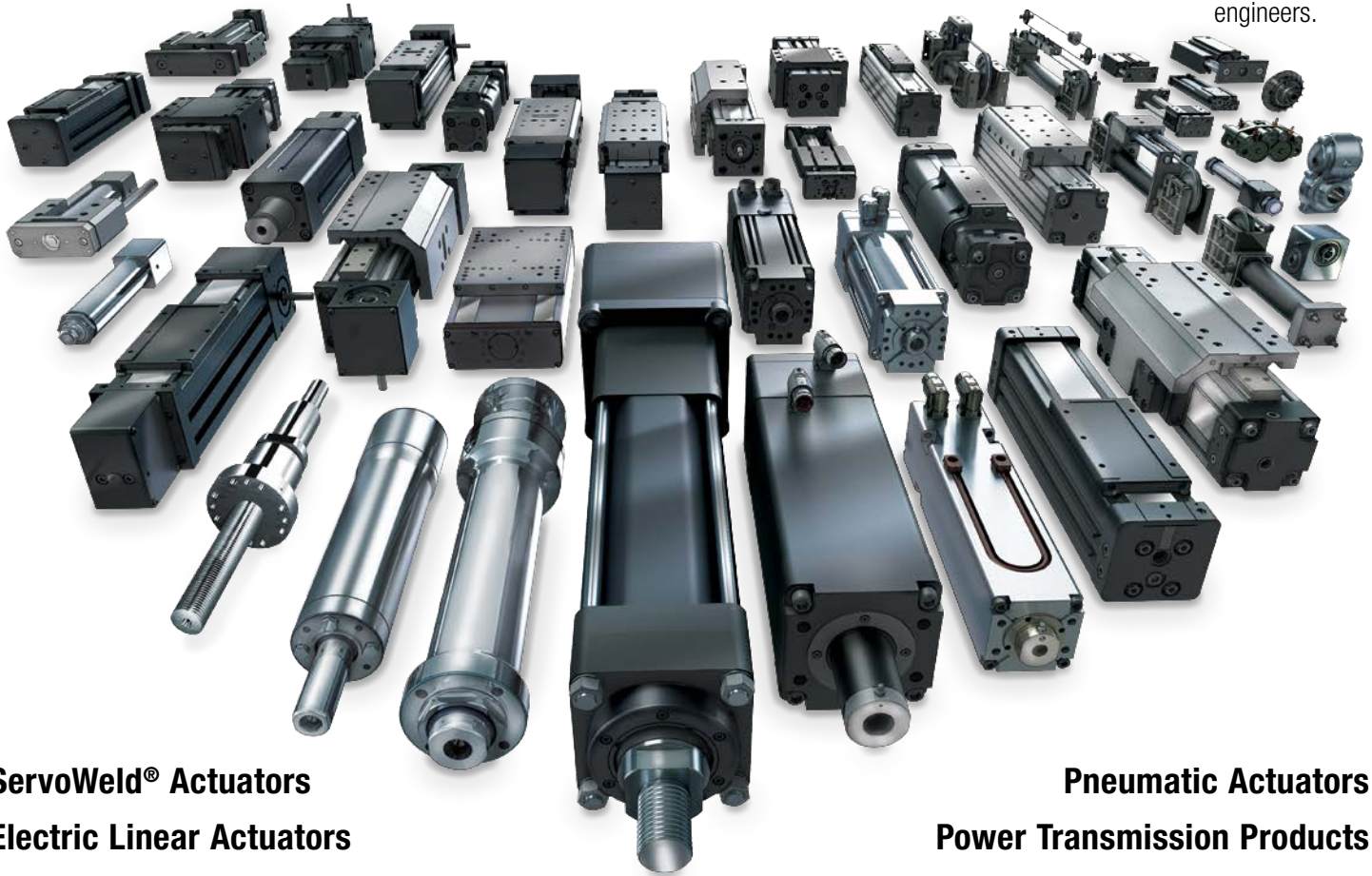

**ServoWeld<sup>®</sup> Actuators**  
**Electric Linear Actuators**

**Pneumatic Actuators**  
**Power Transmission Products**



MADE IN U.S.A.

# Tolomatic<sup>™</sup>

EXCELLENCE IN MOTION

COMPANY WITH  
QUALITY SYSTEM  
CERTIFIED BY DNV  
= ISO 9001 =  
Certified site: Hamel, MN

### USA - Headquarters

#### Tolomatic Inc.

3800 County Road 116  
Hamel, MN 55340, USA  
**Phone:** (763) 478-8000  
Toll-Free: **1-800-328-2174**  
sales@tolomatic.com  
[www.tolomatic.com](http://www.tolomatic.com)

### MEXICO

#### Centro de Servicio

Parque Tecnológico Innovación  
Int. 23, Lateral Estatal 431,  
Santiago de Querétaro,  
El Marqués, México, C.P. 76246  
**Phone:** +1 (763) 478-8000  
help@tolomatic.com

### EUROPE

#### Tolomatic Europe GmbH

Elisabethenstr. 20  
65428 Rüsselsheim  
Germany  
**Phone:** +49 6142 17604-0  
help@tolomatic.eu  
[www.tolomatic.com/de-de](http://www.tolomatic.com/de-de)

### CHINA

#### Tolomatic Automation Products (Suzhou) Co. Ltd.

No. 60 Chuangye Street, Building 2  
Huqiu District, SND Suzhou  
Jiangsu 215011 - P.R. China  
**Phone:** +86 (512) 6750-8506  
Tolomatic\_China@tolomatic.com

All brand and product names are trademarks or registered trademarks of their respective owners. Information in this document is believed accurate at time of printing. However, Tolomatic assumes no responsibility for its use or for any errors

that may appear in this document. Tolomatic reserves the right to change the design or operation of the equipment described herein and any associated motion products without notice. Information in this document is subject to change without notice.

Visit [www.tolomatic.com](http://www.tolomatic.com) for the most up-to-date technical information