

ACW SERIES

- ▶ Direct drive brushless motor
- ▶ Fully integrated with encoder and bearing
- ▶ No cogging torque
- ▶ Precise homing through index pulse
- ▶ Large centre hole
- ▶ Low profile

UK & Ireland Official Distributor



11-15 Francis Avenue, Bournemouth,
Dorset UK BH11 8NX
Tel.: (+44) 01202 599922
enquiries@motioncontrolproducts.com
www.motioncontrolproducts.com

ACW120

ACW120			
Performance Parameters	Symbol	Unit	Parallel
Continuous Torque @100°C ¹	T _{cn}	Nm	0.6
Peak Torque	T _{pk}	Nm	2.1
Torque Constant ±10%	K _t	Nm/Arms	0.14
Back EMF Constant ±10%	K _e	Vpeak/rpm	0.012
Motor Constant @25°C	K _m	Nm/Sqrt(W)	0.10
Resistance (L-L) @25°C ±10% ²	R ₂₅	Ω	1.43
Inductance (L-L) ±20% ³	L	mH	0.47
Electrical Time Constant	τ _e	ms	0.33
Continuous Current @100°C ⁴	I _{cn}	Arms	4.6
Peak Current	I _{pk}	Arms	16.1
Continuous Power Dissipation @100°C ⁵	P _n	W	58.5
Max. Coil Temperature	t _{max}	°C	100
Thermal Dissipation Constant ⁶	K _{thn}	W/°C	0.78
Max. Bus Voltage	U _{bus}	Vdc	330.0
Pole Number	2P	-	16
Max. Speed For Standard Axial/Radial Runout @230V AC ⁴	Ω _{max}	rpm	400
Max. Speed For Optional Axial/Radial Runout (P10, P5) @230V AC ⁴	Ω _{max}	rpm	120
Mechanical Parameters			
Overall Mass	m _n	kg	2.0
Rotor Inertia	J _r	kg.m ²	6.584E-04
Axial Runout ⁷	-	μm	15 (10,5)
Radial Runout ⁷	-	μm	15 (10,5)
Max. Axial Load (Upright Mounting) ⁸	-	N	150.0
Max. Axial Load (Inverted / Wall Mounting)	-	N	15.0
Max. Moment Load (Upright Mounting)	-	Nm	14.7
Max. Moment Load (Inverted / Wall Mounting)	-	Nm	1.47
Encoder Parameters			
ABI Optical Incremental Encoder (SIN/COS)	-	lines / rev	3934
ABI Optical Incremental Encoder (80x)	-	counts / rev	314720
ABI Optical Incremental Encoder (160x)	-	counts / rev	629,440
ABI Optical Incremental Encoder (400x)	-	counts / rev	1,573,600
Accuracy after Error Mapping ⁹	-	arc sec	+/-8
Repeatability ⁹	-	arc sec	+/-4
Other Information			
Insulation Class	Class B (130°C)		
Protection Grade	IP40		
Compliance with Global Standards	RoHS, CE		
Ambient Temperature	Operation	0°C to 40°C (non-freezing)	
	Storage	-15°C to 70°C (non-freezing)	
Ambient Humidity	Operation	10%RH to 80%RH (non-condensing)	
	Storage	10%RH to 90%RH (non-condensing)	
Recommended Ambience	Indoor (no direct sunlight); No corrosive gas, inflammable gas, oil mist or dust.		

- ¹ Measurement is taken at ambient temperature 25°C. Value depends on the thermal environment.
 - ² Resistance is measured by DC current with standard 3 m cable.
 - ³ Inductance is measured by current frequency of 1 kHz.
 - ⁴ The value is based on ABI optical SIN/COS encoder (4096x interpolation) under max. bus voltage.
 - ⁵ The runout value in parenthesis is optional.
 - ⁶ Please refer to the illustration for different mountings.
 - ⁷ Based on ABI optical SIN/COS encoder (4096x interpolation) with P5 runout.
- The contents of datasheet are subjected to change without prior notice.

Dimension

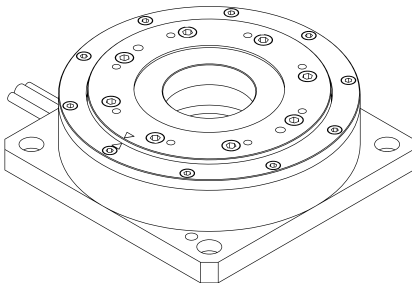

- Note:
- ¹ 37mm diameter through hole
 - ² Shaded area, mounting surface

Torque-Speed Curve

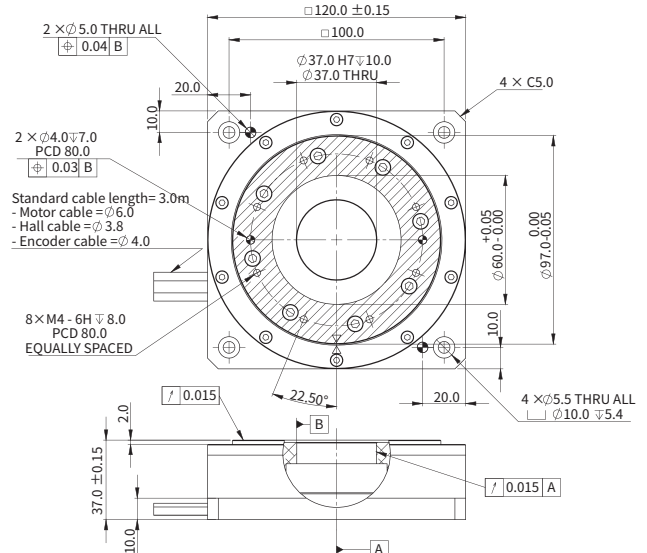
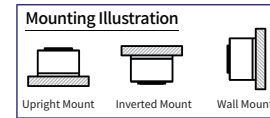
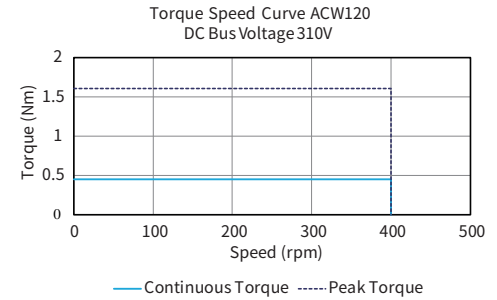

ACW170

Introduction | Sizing Guide | Frequently Asked Questions | Linear Motors | Voice Coil Motors | Direct Drive Rotary Motors | Motion Control of Gantry Stages

ACW170			
Performance Parameters	Symbol	Unit	Parallel
Continuous Torque @100°C ¹	T _{cn}	Nm	2.8
Peak Torque	T _{pk}	Nm	11.9
Torque Constant ±10%	K _t	Nm/Arms	0.66
Back EMF Constant ±10%	K _e	Vpeak/rpm	0.056
Motor Constant @25°C	K _m	Nm/Sqrt(W)	0.32
Resistance (L-L) @25°C ±10% ²	R _{2s}	Ω	2.76
Inductance (L-L) ±20% ³	L	mH	1.65
Electrical Time Constant	τ _e	ms	0.60
Continuous Current @100°C ¹	I _{cn}	Arms	4.2
Peak Current	I _{pk}	Arms	14.7
Continuous Power Dissipation @100°C ¹	P _{cn}	W	94.1
Max. Coil Temperature	t _{max}	°C	100
Thermal Dissipation Constant ¹	K _{thn}	W/°C	1.26
Max. Bus Voltage	U _{bus}	Vdc	330.0
Pole Number	2P	-	16
Max. Speed For Standard Axial/Radial Runout @230V AC ⁴	Ω _{max}	rpm	250
Max. Speed For Optional Axial/Radial Runout (P10, P5) @230V AC ⁴	Ω _{max}	rpm	120
Mechanical Parameters			
Overall Mass	m _n	kg	3.7
Rotor Inertia	J _r	kg.m ²	2.020E-03
Axial Runout ⁵	-	μm	18 (10,5)
Radial Runout ⁵	-	μm	18 (10,5)
Max. Axial Load (Upright Mounting) ⁶	-	N	230.0
Max. Axial Load (Inverted / Wall Mounting)	-	N	23.0
Max. Moment Load (Upright Mounting)	-	Nm	31.7
Max. Moment Load (Inverted / Wall Mounting)	-	Nm	3.17
Encoder Parameters			
ABI Optical Incremental Encoder (SIN/COS)	-	lines / rev	5560
ABI Optical Incremental Encoder (80x)	-	counts / rev	444800
ABI Optical Incremental Encoder (160x)	-	counts / rev	889,600
ABI Optical Incremental Encoder (400x)	-	counts / rev	2,224,000
Accuracy after Error Mapping ⁷	-	arc sec	+/-6
Repeatability ⁷	-	arc sec	+/-3
Other Information			
Insulation Class	Class B (130°C)		
Protection Grade	IP40		
Compliance with Global Standards	RoHS, CE		
Ambient Temperature	Operation	0°C to 40°C (non-freezing)	
	Storage	-15°C to 70°C (non-freezing)	
Ambient Humidity	Operation	10%RH to 80%RH (non-condensing)	
	Storage	10%RH to 90%RH (non-condensing)	
Recommended Ambience	Indoor (no direct sunlight); No corrosive gas, inflammable gas, oil mist or dust.		

Torque-Speed Curve

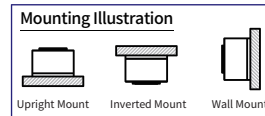
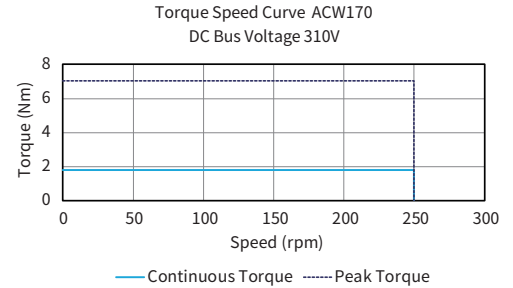

- ¹ Measurement is taken at ambient temperature 25°C. Value depends on the thermal environment.
 - ² Resistance is measured by DC current with standard 3 m cable.
 - ³ Inductance is measured by current frequency of 1 kHz.
 - ⁴ The value is based on ABI optical SIN/COS encoder (4096x interpolation) under max. bus voltage.
 - ⁵ The runout value in parenthesis is optional.
 - ⁶ Please refer to the illustration for different mountings.
 - ⁷ Based on ABI optical SIN/COS encoder (4096x interpolation) with P5 runout.
- The contents of datasheet are subjected to change without prior notice.

Dimension

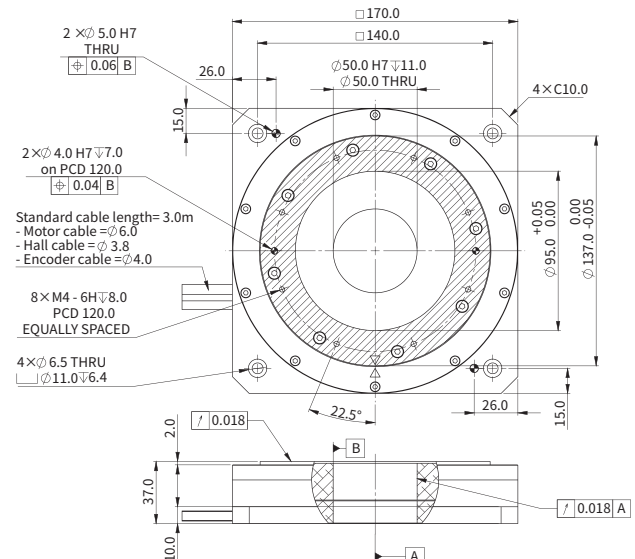
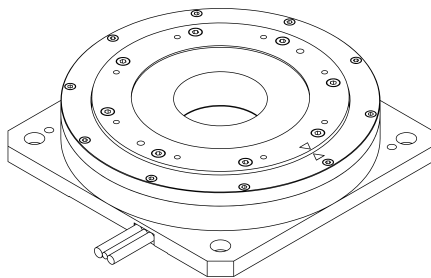

- Note:
- ¹ 50mm diameter through hole
 - ² Shaded area, mounting surface

ACW220

ACW220			
Performance Parameters	Symbol	Unit	Parallel
Continuous Torque @100°C ¹	T _{cn}	Nm	7.4
Peak Torque	T _{pk}	Nm	35.9
Torque Constant ±10%	K _t	Nm/Arms	1.95
Back EMF Constant ±10%	K _e	Vpeak/rpm	0.167
Motor Constant @25°C	K _m	Nm/Sqrt(W)	0.71
Resistance (L-L) @25°C ±10% ²	R ₂₅	Ω	5.06
Inductance (L-L) ±20% ³	L	mH	4.72
Electrical Time Constant	τ _e	ms	0.93
Continuous Current @100°C ¹	I _{cn}	Arms	3.8
Peak Current	I _{pk}	Arms	13.3
Continuous Power Dissipation @100°C ¹	P _n	W	141.3
Max. Coil Temperature	t _{max}	°C	100
Thermal Dissipation Constant ¹	K _{thn}	W/°C	1.88
Max. Bus Voltage	U _{bus}	Vdc	330.0
Pole Number	2P	-	16
Max. Speed For Standard Axial/Radial Runout @230V AC ⁴	Ω _{max}	rpm	190
Max. Speed For Optional Axial/Radial Runout (P10, P5) @230V AC ⁵	Ω _{max}	rpm	120
Mechanical Parameters			
Overall Mass	m _n	kg	7.0
Rotor Inertia	J _r	kg,m ²	8.354E-03
Axial Runout ⁶	-	μm	18 (10,5)
Radial Runout ⁶	-	μm	18 (10,5)
Max. Axial Load (Upright Mounting) ⁶	-	N	300.0
Max. Axial Load (Inverted / Wall Mounting)	-	N	30.0
Max. Moment Load (Upright Mounting)	-	Nm	55.2
Max. Moment Load (Inverted / Wall Mounting)	-	Nm	5.52
Encoder Parameters			
ABI Optical Incremental Encoder (SIN/COS)	-	lines / rev	7500
ABI Optical Incremental Encoder (80x)	-	counts / rev	600000
ABI Optical Incremental Encoder (160x)	-	counts / rev	1,200,000
ABI Optical Incremental Encoder (400x)	-	counts / rev	3,000,000
Accuracy after Error Mapping ⁷	-	arc sec	+/-6
Repeatability ⁷	-	arc sec	+/-3
Other Information			
Insulation Class	Class B (130°C)		
Protection Grade	IP40		
Compliance with Global Standards	RoHS, CE		
Ambient Temperature	Operation	0°C to 40°C (non-freezing)	
	Storage	-15°C to 70°C (non-freezing)	
Ambient Humidity	Operation	10%RH to 80%RH (non-condensing)	
	Storage	10%RH to 90%RH (non-condensing)	
Recommended Ambience	Indoor (no direct sunlight); No corrosive gas, inflammable gas, oil mist or dust.		

- ¹ Measurement is taken at ambient temperature 25°C. Value depends on the thermal environment.
 - ² Resistance is measured by DC current with standard 3 m cable.
 - ³ Inductance is measured by current frequency of 1 kHz.
 - ⁴ The value is based on ABI optical SIN/COS encoder (4096x interpolation) under max. bus voltage.
 - ⁵ The runout value in parenthesis is optional.
 - ⁶ Please refer to the illustration for different mountings.
 - ⁷ Based on ABI optical SIN/COS encoder (4096x interpolation) with P5 runout.
- The contents of datasheet are subjected to change without prior notice.

Dimension

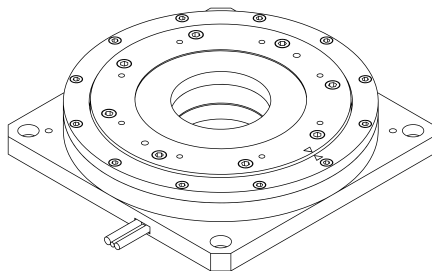

- Note:
- ¹ 70mm diameter through hole
 - ² Shaded area, mounting surface

Torque-Speed Curve

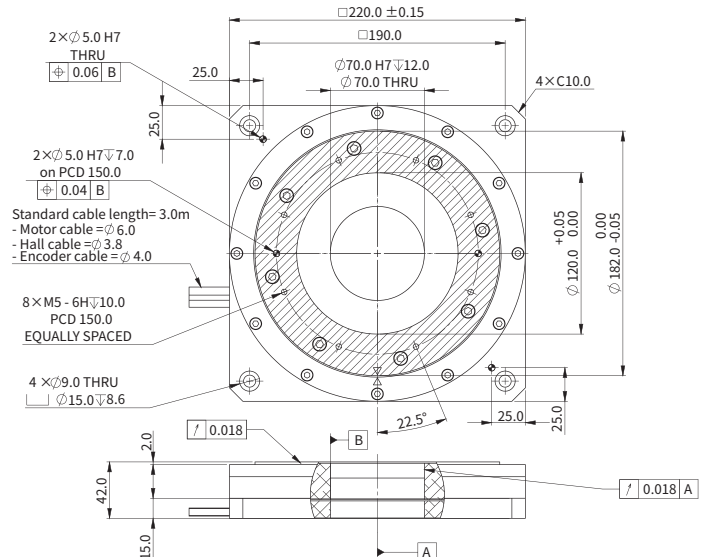
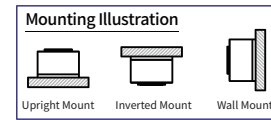
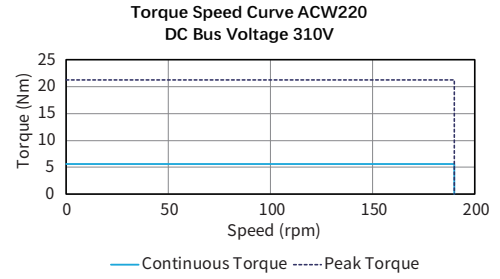

Motor Cable Connection Diagram

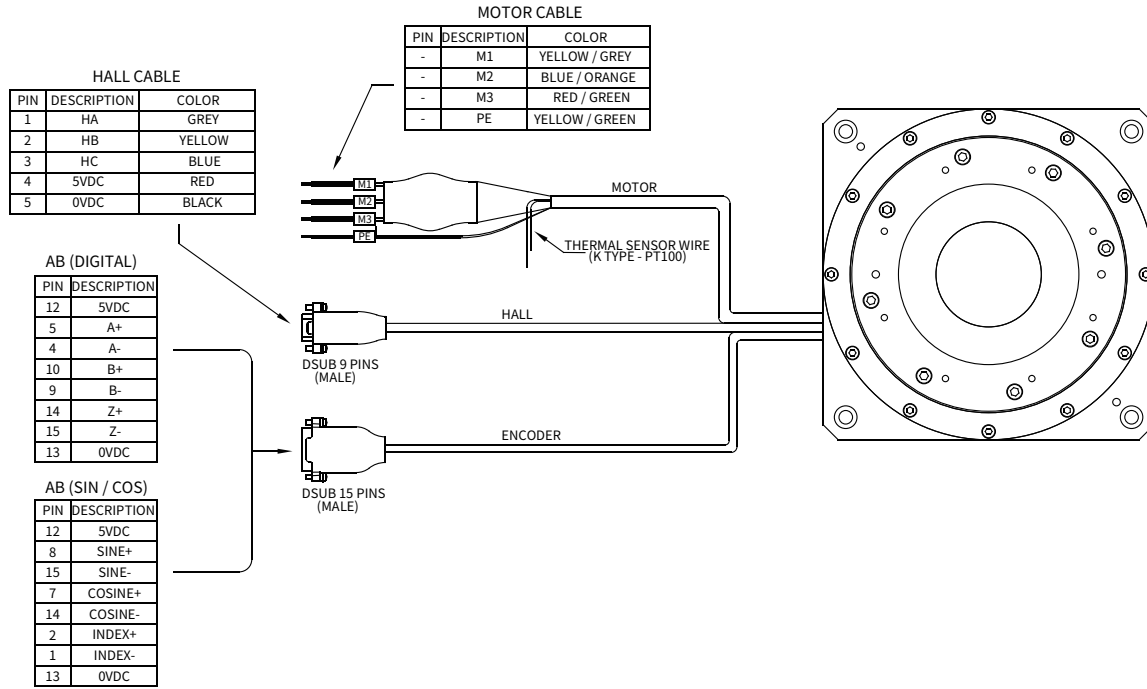

Part Numbering

ACW170-37-P-K-NH-0.5-FB-AB-5560-SINCOS-P18

Motor Model:

ACW120-37
ACW170-37
ACW220-42

Winding:

P=Parallel

Thermal Sensor Options:

K=PT100 (RTD)

Hall Cable Option:

NH/H9D

Cable Length (m):

0.5

Runout:

P5
P10
P15
P18

Interpolation Options:

SINCOS / 80X / 160X / 400X

Encoder:

ACW120:AB-3934
ACW170:AB-5560
ACW220:AB-7500

Motor Cable Option:

FB / 9W4M

- ① NH = Without Built-in Hall Sensor but with Thermal Sensor.
- ② H9D = With Built-in hall sensor, comes with 9-Pins D-Sub Connector.
- ③ FB = With ferrite bead.
- ④ 9W4M = C/W D-Sub 9W4 Male Connector, no Ferrite Bead.
- ⑤ ACW120 / ACW170 / AXW220:P5= Axial Runout 5µm, Radial Runout is 5µm
ACW120 / ACW170 / AXW220:P10= Axial Runout 10µm, Radial Runout is 10µm
ACW120:P15= Axial Runout 15µm, Radial Runout is 15µm
ACW170 / AXW220:P18= Axial Runout 18µm, Radial Runout is 18µm

