

PROVEN PERFORMANCE

Customers in over 60 countries and in diverse markets and sectors.



UK & Ireland Official Distributor



Motion Control Products Ltd.
11-15 Francis Avenue, Bournemouth
Dorset, UK, BH11 8NX
Tel.: +44 (0)1202 599922
enquiries@motioncontrolproducts.com
www.motioncontrolproducts.com

Kinco® Automation

www.en.kinco.cn Email:sales@kinco.cn

(All trademarks and logos in this brochure are property of and registered by their respective owners.)

Kinco

UK & Ireland Official Distributor



Motion Control
Servo System

Kinco i Series General Catalogue

- iWMC Integrated Servo Wheel
- iSMK drive and motor integrated machine



About us

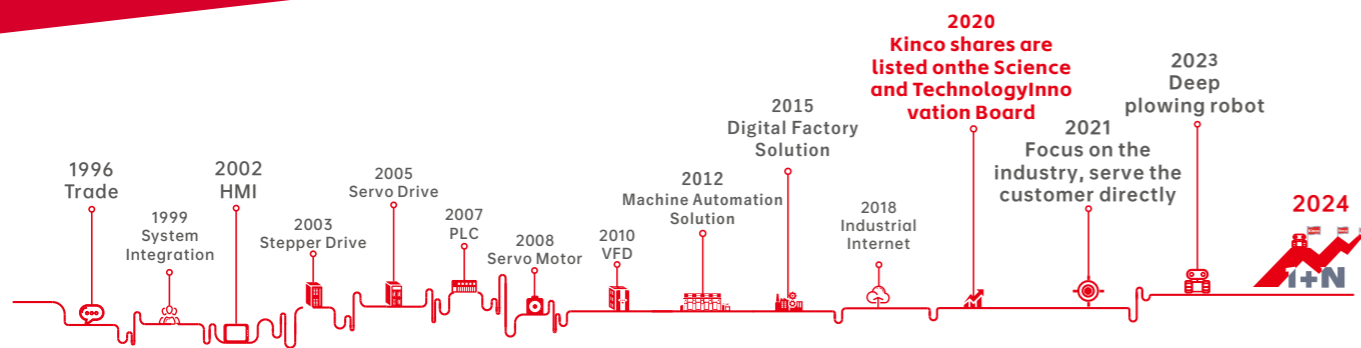

Kinco was founded in 1996, and successfully listed on the Shanghai Stock Exchange in 2020 (abbreviated name: Kinco share, stock code 688160), which is a high-tech, specialized and sophisticated enterprise that attaches great importance to independent research and development and innovation, mainly engaged in the research and development, production, sales and related technical services of industrial automation and robot core components and digital factory hardware and software. It is a leading supplier of automation control, robot power and digital factory solutions in China.

After years of continuous research and development and innovation, Kinco has established a complete product line with independent intellectual property rights, covering a series of products from machine iot to human-machine interaction, control, drive and execution, which are widely used in robots, medical equipment, logistics equipment, packaging equipment, food equipment, clothing equipment, environmental protection equipment, etc. New energy equipment, rail transit equipment and other automation equipment industry.

Based on the comprehensive industrial automation and digital technology platform, the company has in-depth application scenarios in the robot industry, providing display, control, drive and other multi-dimensional solutions for industrial mobile robots, collaborative robots, industrial robots, pan-service robots, and bionic robots. Through the insight of the industry pain points, deep links with robot customers, combined with the advantages of product research and development, the company continues to innovate, and launches industry-leading low-voltage servo products for mobile robots, integrated servo wheel, frameless torque motor for collaborative robots, robot human-machine interfaces, robot controllers and other products. The company has formed a relatively complete robot core parts capability, and after nearly 10 years of hard work in the robot industry, it has become a leading enterprise in the field of mobile robot low-voltage servo, and has a high brand influence in the industry.

Kinco has four research and development centers in Shanghai, Shenzhen, Changzhou and Chengdu, and two manufacturing bases in Shenzhen and Changzhou, a total of 10+ domestic marketing centers, 100+ domestic service providers, 40+ global partners, and products are exported to 70+ countries overseas. In terms of after-sales service, Kinco has established after-sales service centers in Shanghai, Shenzhen and Changzhou.

i-Kinco is a new integration concept proposed by Kinco based on the technology trend.

The core of i-Kinco is the integration, and compatibility of power components, it takes motor technology as the core, and integrates with drive, reducer, encoder, sensor and other technologies as a whole, developing small volume, lightweight, high protection, easy maintenance of power module. With the ultimate integrated innovative solution, it reduces the comprehensive use cost including hardware, debugging, maintenance, etc. for customers.

In addition, i-Kinco will focus on the robot power standardization construction, deeply explore common needs, and develop standardized products with the universality of subdivided industries, as far as possible to reduce the additional costs caused by customer customization, while improving delivery efficiency. iWMC, iSMK and other products have been launched, will continue to launch more i integrated product.

Ultimate integration all in i-Kinco



Reduce space occupation Reduce design difficulty Simplify installation process

Release cost reduction space Energy saving and efficiency improvement

Improve space utilization:

The integrated product structure is compact, which is conducive to the miniaturization of the vehicle body;

Improve installation efficiency:

Modular vehicle power components, high reliability and can be quickly assemble and disassemble, installation time saving 50%;

Reduce costs:

Integrated and modular products reduce procurement communication costs and overall equipment manufacturing costs;

Assist in going global:

With CE/UL/STO/dual encoder and other safety certifications, it can meet the safety standard requirements of different markets at domestic and international.

Contents

03 iWMC Integrated Servo Wheel

Naming Rules

Parameter Specifications

Dimension Diagram

External Wiring Diagram

Explanation of Wiring Ports

07 Integrated Servo Motor

Naming Rules

Technical Parameters

Dimension Diagram

Explanation of Wiring Ports

iWMC Integrated Servo Wheel

Highly integrated: The four main components of the driver, motor, gearhead, and wheel are highly integrated, resulting in a compact structure that facilitates downsizing;

High mounting accuracy: Supported mounting, simple and convenient mounting method, high mounting accuracy, and high control accuracy;

High reliability: The integrated module, with only external power supply and communication cables, is resistant to nickel-contacts and improves the stability and reliability of the entire system;

Compatible design & seamless switching: the communication and usage modes of the servo wheel products are no different from those of the standard Kinco products, allowing seamless switching;

Good maintainability: A single supplier for the integrated product facilitates the maintenance of the product at a later stage and reduces supply chain and after-sale costs.



- ☑ Design of dual power supply for driver
- ☑ Support external forced unlocking
- ☑ Standard CANopen communication protocol
- ☑ The reducer has low back seam and high precision

■ Application Scenario

Power Servo Wheel Module for Mobile Machines with Loads up to 600 kg

Power Servo Wheel Module for Mobile Machines with Loads up to 1 T

■ Naming convention

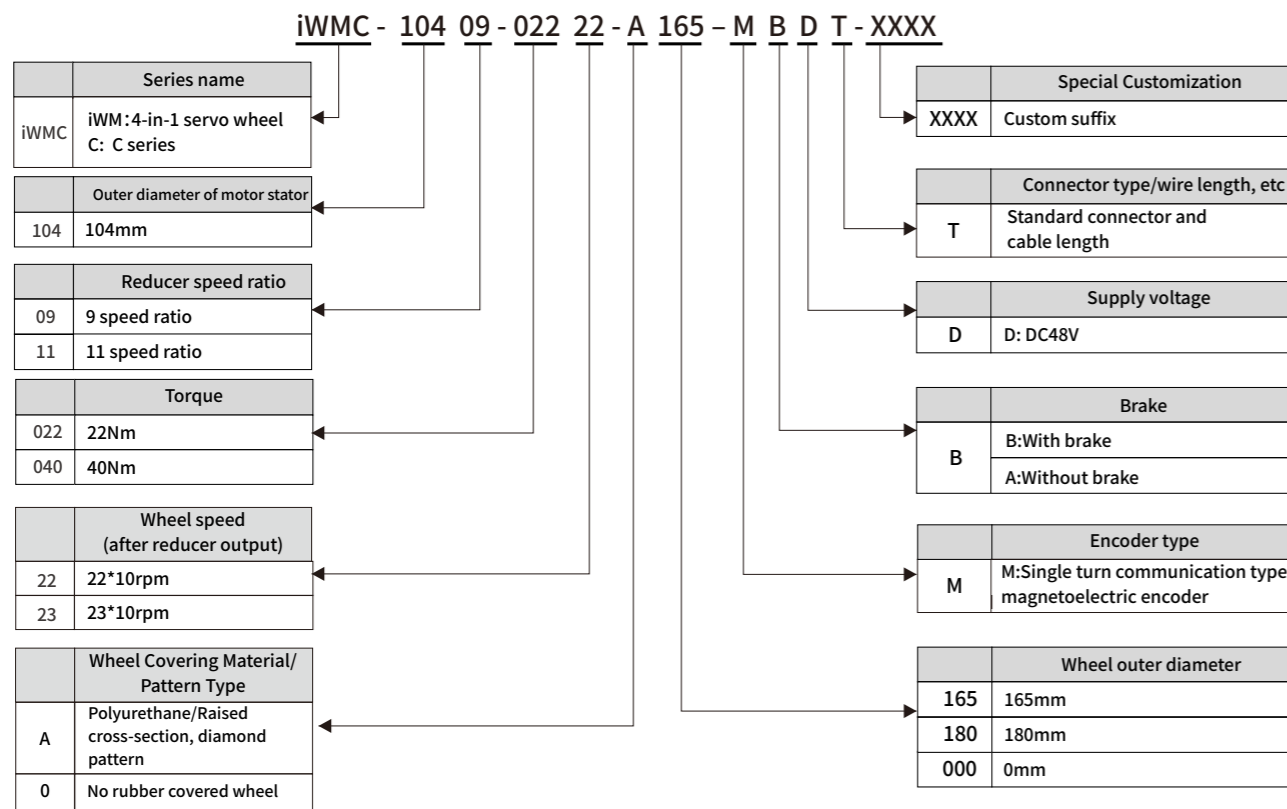

Parameter Specifications

■ Product Parameters

iWMC Integrated Servo Wheel Model Number		iWMC10409-02222-A165-M■DT	iWMC10411-04023-A180-M■DT
Power	Power Supply	24VDC~60VDC	
	Logic Supply	24VDC	
Rated Linear Speed (m/s)		1.9	2.14
Rated Torque Tn(Nm)		21	40
Peak Torque Tn(Nm)		60	99
Tire Diameter (mm)		165	180
Tire Width(mm)		39.5	50
Tire Material		Polyurethane (optional)	
Tire Hardness Rating		85A	90A
Energy Consumption Braking		External braking resistor is required (depending on the operating conditions, mainly used for rapid starting and stopping)	
Energy Consumption Braking Voltage Absorption Point		DC63V ± 2V(Default, settable)	
Overvoltage alarm point		DC68V ± 2V	
Undervoltage alarm point		DC18V ± 2V	
Input Specifications		2 digital inputs / Common COMI terminal / High level: 12.5-30VDC / Low level: 0-5VDC / Maximum frequency: 1KHz / Input impedance: 5KΩ.	
Output Specifications		1 digital output common COMO terminal / Maximum output current: 100mA	
Brake		Built-in brake and control circuit	
Forced Unlock Interface		1-way forced unlock interface, only for use when there is no power input to the servo wheel	
RS485 Debug Port		Maximum support for 115.2Kbps baud rate	
CAN BUS		Maximum support for 1Mbps baud rate, CANopen protocol can be used to communicate with the controller	
Drive Current	Max. continuous output current (rms)	16A	26A
	Peak Current (PEAK)	100Ap(<2s)	100Ap(<2s)
	Rated RPM nN(rpm)	2000	2500
Motor	Rated Torque Tn(Nm)	2.4	4
	Brake Holding Torque T(Nm)	4	
Noise		<65dB	
Cooling Methods		Natural cooling & Body-assisted cooling	
Operating Environment	Operating Temperature	0~40°C	
	Storage Temperature	-20°C~60°C	
	Humidity (non-condensing)	90%RH below	
	Protection Level	IP54	
	Altitude	The rated working altitude is up to 1000m above sea level. For working altitudes above 1000m, a reduction of 1.5% is required for every 100 meters of rise in altitude, with a maximum working altitude of 2000 meters above sea level.	
Atmospheric Pressure	86kpa~106kpa		

Note: ■ = A : Without brake B : With brake

Dimension Diagram & External Wiring Diagram

■ iWMC10409-02222-A165-M ■ DT

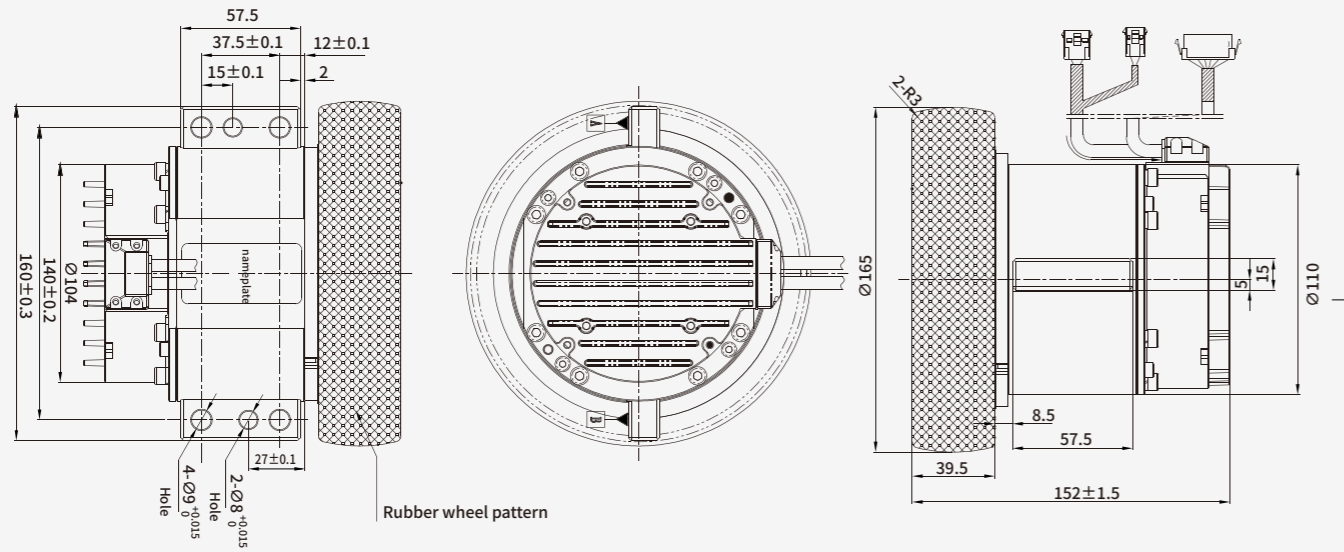

■ iWMC10411-04023-A180-M ■ DT

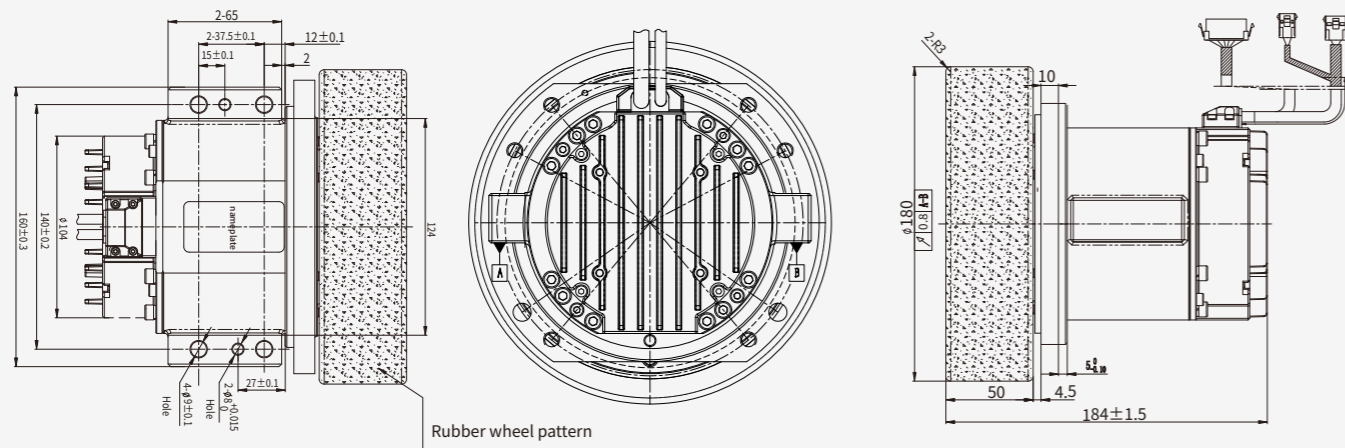

■ External Wiring Diagram

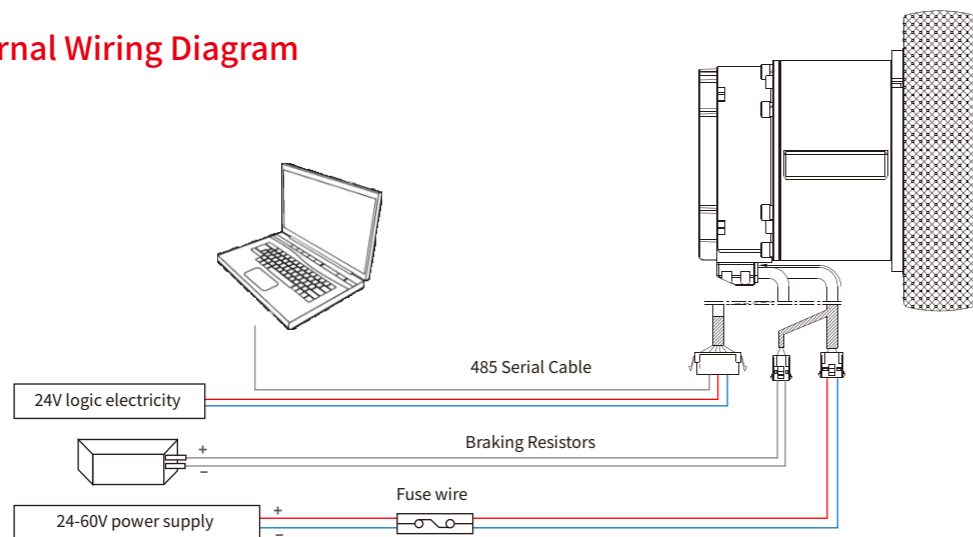

Explanation of Wiring Ports

■ Terminal definition

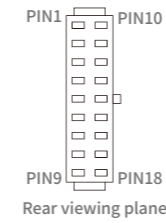

PIN	signal	PIN	signal
1	24V	10	GND
2	LOCK+	11	LOCK-
3	CANH	12	CANL
4	CANH	13	CANL
5	485A	14	485B
6	485A	15	485B
7	OUT1+	16	COMO
8	COMI	17	DI1
9	Empty	18	DI2

iWMC Integrated Servo Wheel Control Wiring Diagram

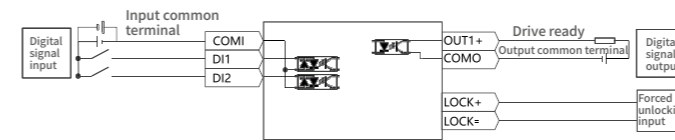

Wiring Diagram of Recommended Circuit for Forced Unlocking Brake

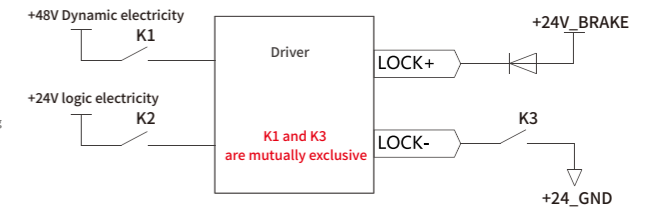

Note: The forced unlocking function needs to be used after the power supply of the servo wheel is cut off.

Power port

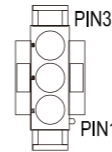

Pin number	Pin name	Pin function
3	DC-	The input end of the power supply of the driver must be connected
1	DC+	Input voltage: 24~60VDC

Brake resistance port

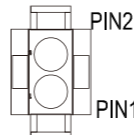

Pin number	Pin name	Pin function
1	RB+	External braking resistor input terminal
2	RB-	

iSMK drive and motor integrated machine

Product features:

Compact body, highly integrated motor, driver, encoder and brake in one;

Support 24 ~ 60VDC wide voltage.
Supports CANopen, Modbus RTU, EtherCAT, etc.
A variety of safety protection measures such as overvoltage protection, under pressure protection, short-circuit protection, motor overheating (IIT) protection, and driver overheating protection;
Can be equipped with a standard reducer, suitable for rotary jacking and other scenes.



iSMK naming rules

型号: iSMK60-040-DMAK-AA-000

① ② ③ ④ ⑤ ⑥ ⑦ ⑧ ⑨

①-Series name	iSMK: iSMK Integrated servo motor	⑥-Brake	A: Without brake B: With brake
②-Flange	40: 40x40(mm) 60: 60x60(mm) 80: 80x80(mm)	⑦-Output axis style	K: With key
③-Rated power	010: 10x10(W) 020: 20x10(W) 040: 40x10(W) 075: 75x10(W)	⑧-Contro mode	AA: RS485、CANopen、Not pulse、 24V logic power supply EA: RS485、EtherCAT、Not pulse、 24V logic power supply
④-Supply voltage	D: Input Voltage DC24~60V	⑨-Software version number	000: Software version number
⑤-Encoder type	M: Singleturn communication type magnetolectric encoder		

Note: The oil seal is an optional accessory, and it can be omitted if it is not necessary.

iSMK integrated servo drive motor technical parameters



Model parameter		iSMK drive and motorintegrated machine			
		iSMK40-010-DM■K-□A-000	iSMK60-020-DM■K-□A-000	iSMK60-040-DM■K-□A-000	iSMK80-075-DM■K-□A-000
Input	power	24VDC~60VDC			
	Built-in fuse	Null			
	Logic power	24V			
Output	Maximum continuous output current (rms)	4	7	12	23
	Peak current (AP)	18	24	48	100
Motor part	Rated power Pn(W)	100	200	400	750
	Rated speed nN(rpm)	3000	3000	3000	3000
	Rated torque Ts(Nm)	0.32	0.64	1.27	2.39
	Maximum torque Tm(Nm)	0.96	1.92	3.81	7.17
	Rotational inertia Jm (Kg·cm ²)	0.044 0.046 (With brake)	0.17 0.174 (With brake)	0.31 0.314 (With brake)	0.85 0.91 (With brake)
Logic loss power (mW)		900			
Energy consumption brake		There is no brake circuit inside the driver, and an external brake module is required			
Overvoltage alarm voltage		The default is 68V			
Undervoltage alarm voltage		The default is 18V			
Cooling mode		Natural cooling			
General function	Input specification	2 digital inputs, high: 12.5VDC ~ 30VDC Low: 0VDC ~ 5VDC Input impedance: 5KΩ Input frequency: <1KHz			
	Input function	Freely defined as required, the functions are as follows: drive enable, drive error reset, drive mode control, speed loop proportional control, positive limit, negative limit, origin signal, command reverse, internal speed segment control, internal position segment control, emergency stop, start to find the origin, command activation, electronic gear ratio switching, gain switching			
	Output specification	1 digital output, OUT1 for the open collector output, the highest voltage 30V, driving capacity of 100mA			
Bus function	Output function	Freely defined according to needs, the functions are as follows: driver ready, driver error, motor position to, motor zero speed, motor lock brake, motor speed to, index Z signal appears, maximum limit speed in torque mode, motor lock shaft, motor limit medium, origin finding			
	RS485	It supports a maximum 115.2Kbps baud rate and can communicate with the controller using the Modbus RTU			
	CANopen	It supports a maximum 1Mbps baud rate and can communicate with the controller using the CANopen			
Apply environment	EtherCAT	Support CoE(CiA402 protocol)and CSP/CSV/PP/PV/PT/HM mode, communication speed 100M			
	Operation temperature	-20°C~40°C (no freezing) ,When the operating temperature exceeds 40°C, the driver needs to be derated			
	Operating humidity	Less than 90%RH (no condensation)			
	Storage temperature	-40°C~70°C (no freezing)			
	Storage humidity	90%RH (no condensation)			
	Installation method	Motor flange installation (vertical side installation)			
	Protection grade	IP65, shaft end IP54			
Atmospheric pressure	86kpa~106kpa				
Altitude	The rated working altitude is less than 1000 meters above sea level. When the working altitude is higher than 1000 meters, it is necessary to reduce the rated value by 1.5% for every 100 meters of elevation. The maximum working altitude is 2000 meters above sea level.				

Note1: ■=A: Without brake
=B: With brake (Power supply conversion, external unlocking.)
Note2: □=A: RS485、CANopen
=E: RS485、EtherCAT

iSMK integrated servo drive motor mechanical dimensions

iSMK40 series mechanical dimension diagram (unit: mm)

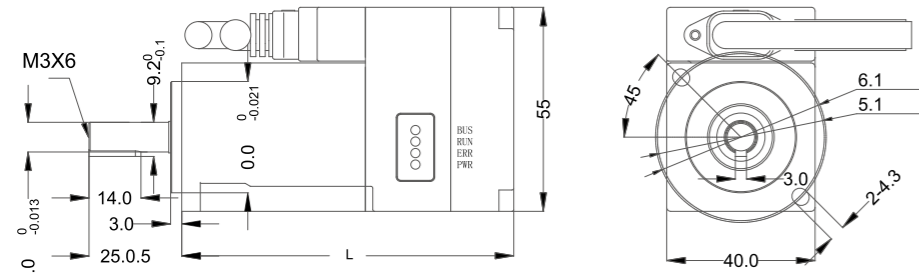

iSMK40 series model	With brake	Weight(kg)	Motor body size L (mm)
iSMK40-010-DMAK-AA-000		0.6	92
iSMK40-010-DMBK-AA-000	✓	0.8	126
iSMK40-010-DMAK-EA-000		0.7	92
iSMK40-010-DMBK-EA-000	✓	0.9	126

iSMK60 series mechanical dimension diagram (unit: mm)

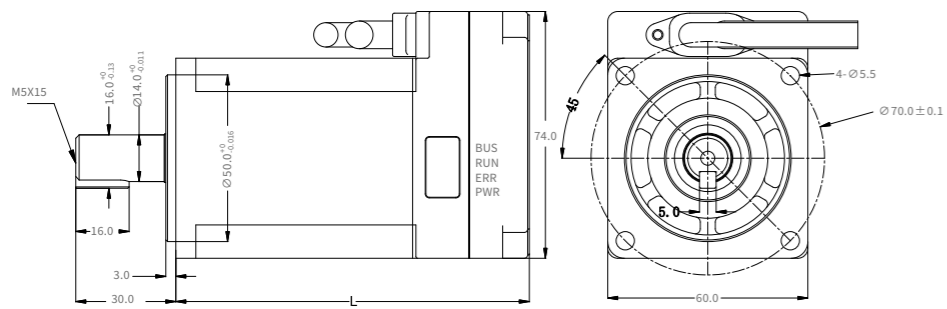

iSMK60 series model	With brake	Weight(kg)	Motor body size L (mm)
iSMK60-020-DMAK-AA-000		1.1	88
iSMK60-020-DMBK-AA-000	✓	1.6	127.5
iSMK60-020-DMAK-EA-000		1.2	88
iSMK60-020-DMBK-EA-000	✓	1.7	127.5
iSMK60-040-DMAK-AA-000		1.3	106
iSMK60-040-DMBK-AA-000	✓	1.8	145.5
iSMK60-040-DMAK-EA-000		1.4	106
iSMK60-040-DMBK-EA-000	✓	1.9	145.5

iSMK80 series mechanical dimension diagram (unit: mm)

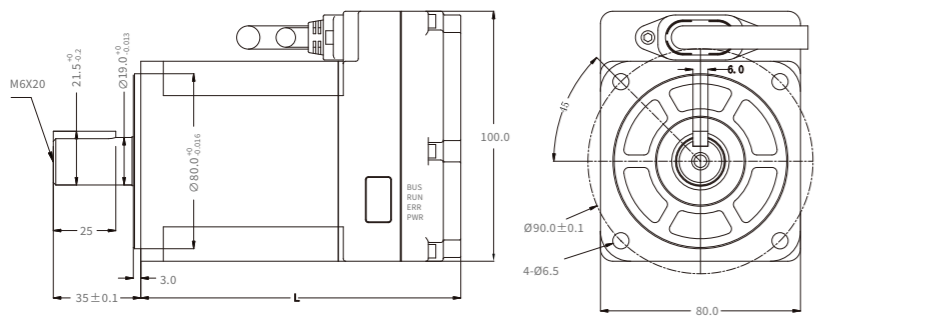

iSMK80 series model	With brake	Weight(kg)	Motor body size L (mm)
iSMK80-075-DMAK-AA-000		2.5	128
iSMK80-075-DMBK-AA-000	✓	3	158
iSMK80-075-DMAK-EA-000		2.6	128
iSMK80-075-DMBK-EA-000	✓	3.1	158

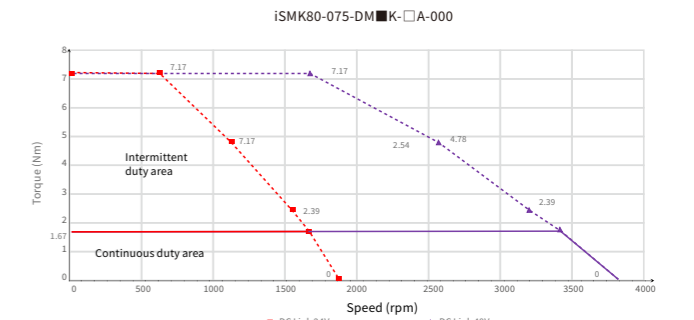
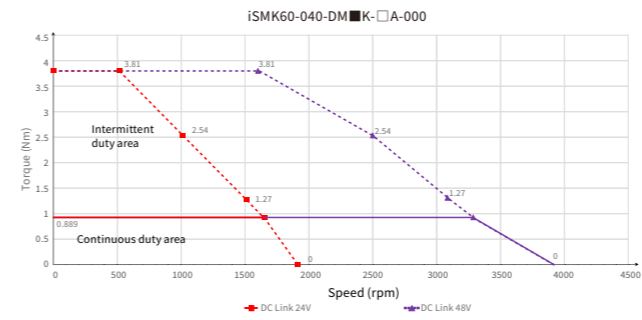
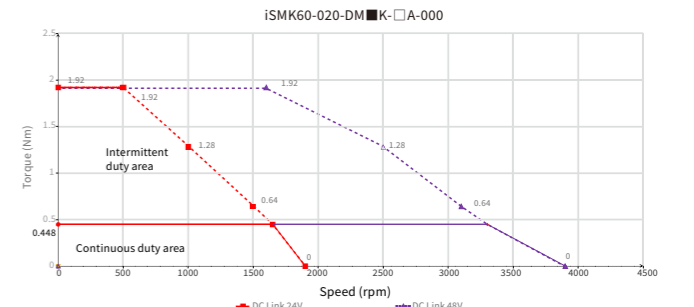
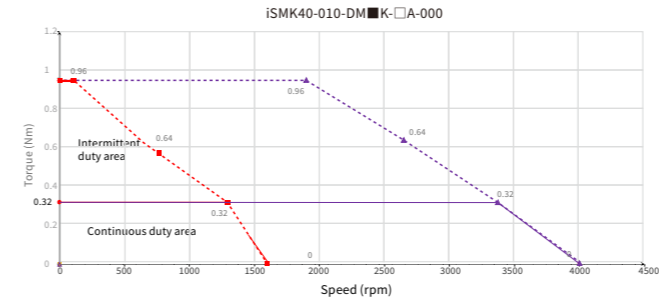

iSMK integrated servo drive motor connection port description

iSMK-AA communication terminal definition

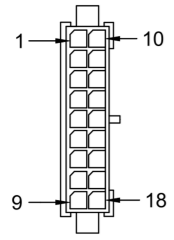

A			B		
Pin	Name	Cable color	Pin	Name	Cable color
1	24V	Red	10	GND	Black
2	LOCK+	Purple	11	LOCK-	Purple and black
3	CANH	Blue and black	12	CANL	Blue
4	CANH	Blue and black	13	CANL	Blue
5	RS485A	Orange and black	14	RS485B	Orange
6	RS485A	Orange and black	15	RS485B	Orange
7	OUT1+	Yellow and black	16	COMO	Yellow
8	COMI	White	17	DI1	Green
9	GND	Green and black	18	DI2	White and black

Note: This definition applies to iSMK40&60&80AA.
EXC-iSMK-AA-LL external cable can be purchased.

iSMK-EA communication terminal definition

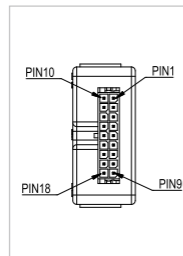
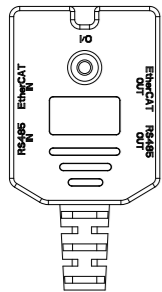

A		B	
PIN	Signal	PIN	Signal
1	24V	10	GND
2	LOCK+	11	LOCK-
3	/	12	/
4	/	13	/
5	RS485A	14	RS485B
6	RS485A	15	RS485B
7	OUT1+	16	COMO
8	COMI	17	DI1
9	GND	18	DI2

Note: Kinco EXC-iSMK-AA-LL external cable can be purchased
(Pins 3, 4, 12, 13 of the iSMK-EA series are empty, and the corresponding color cable of these four pins of the external cable can be ignored)

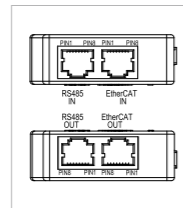

PIN	Rs485 IN/RS485 OUT	EtherCAT IN	EtherCAT OUT
1	/	IN TX+	OUT TX+
2	/	IN TX-	OUT TX-
3	/	IN RX+	OUT RX+
4	GND_C	/	/
5	RS485B	/	/
6	RS485A	IN RX-	OUT RX-
7	/	/	/
8	/	/	/

IO signal description

Signal	Function description
24V	The logic power supply is an optional option. When using the logic power supply, ensure that the power supply and logic are completely isolated. If the system power supply is not isolated, the logical ground cable is not connected. The logic power supply is connected at DC- and 24V
GND	Logic electrical reference ground
LOCK+	External release beake input The input voltage is 24V, the maximum input current is 0.7A, only when the AGV body battery is out of emergency use;
LOCK-	Only when both the logic power supply and the power supply are powered off, the external lock can be unlocked. Do not short-circuit or connect to other signals and enclosures during normal operation
CANH	CAN signal positive end(Only the iSMK-AA series has this terminal)
CANL	CAN signal negative end(Only the iSMK-AA series has this terminal)
485A	RS485 data positive end
485B	RS485 data negative end
GND_C	Signal ground
DIN1	Digital signal input; High level: 12.5VDC~30VDC Low level: 0VDC~5VDC Input impedance: 5KΩ Input frequency: <1KHz
DIN2	
COMI	Digital signal input to the common end
OUT1+	Digital signal output; 1 digital output, maximum output current: 100mA
COMO	Digital signal output common terminal